

DMC Pump

DMC Spilt Casing Pump Catalog



SHANGHAI PUMPING TECH INTERNATIONAL CO.,LTD



Main office:

Add: No.6 Building, No.2999 Hutai Av, Baoshan district, SHANGHAI, 200062, CHINA

E-mail: infor@aikonchina.com

Website: www.aikonchina.com

Moscow office:

Add: Moscow, Volokolamsk highway, 73, office 210

Tel: +7-499-703-35-23 +7-800-333-10-74

E-mail: aikon@aikonrussia.ru

Website: www.aikonrussia.ru

SHANGHAI PUMPINGTECH INTERNATIONAL CO.,LTD

产品概述

DMC型轴向中开标准双吸离心泵是我公司与沈阳水泵研究所联合开发的处于国际领先地位的高效节能产品，获得国家专利(专利号：ZL 01 2 39077.1)。该系列泵具有立卧两用的独特特点，填补了国内空白，并通过国家工业泵质量监督检测中心检测合格。与原S、SH、SA型泵相比，优势突出，是理想的替代产品。

主要用途

DMC系列轴向中开标准双吸离心泵用于自来水厂、灌溉、排水泵站、电站、工业供水系统、消防系统、船舶工业，还可用于炼油工业、民用建筑给排水、暖通制冷、冶金、化工、制药等领域。用于输送清水或物理化学性质类似于水的液体及弱腐蚀性的化学介质。

运行数据

| | | |
|-------|----|-----------|
| 泵出口直径 | DN | 80-800mm |
| 流量 | Q | 最大3100L/S |
| 扬程 | H | 最高200m |
| 工作压力 | P | 最高2.5MPa |
| 工作温度 | T | 最高120℃ |

General description

Type CMD standard axially split double suction pump is jointly developed by Shenyang pump research institute and our company. The product is world leading in technology content and properties, with high efficiency and energysaving and awarded national patent (application No: ZL 01 2 39077.1). This series pump has unique vertical and horizontal construction, filling up the blank in domestic, and has proved accredited product by National industry pump quality suspension and test center. It is an ideal product for replacing type S、SH、SA pumps.

Applications

Type DMC pumps is widely used in water works, irrigation, drainage water station, power station, industrial water supply, fire fighting system, marine engineering, it can also be applied in refinery industry, water supply and drainage in building, water circulation system of air-condition, metallurgy, chemical process, pharmacy, etc. suitable for pum-ping clean water or other liquids which chemical and physical property are similiary to water.

Operation date

| |
|--|
| <i>Pump discharge diameter: DN 80-800mm</i> |
| <i>Capacity: Q_{max} 3100L/S</i> |
| <i>Head: H_{max} 200m</i> |
| <i>Operating pressure: P_{max} 2.5MPa</i> |
| <i>Operating temperature: T_{max} 120℃</i> |

型号意义

DMC (DMCL) 100 - 310E (F) G - 1 (2, 3, 4)

DMC — 卧式标准双吸离心泵

DMCL — 立式标准双吸离心泵

100 — 泵出口直径(mm)

310 — 叶轮名义直径(mm)

E (F) — 叶轮水力模型编号

G — 电机转速(2900r/min), 其它转速不标

1 (2, 3, 4) — 叶轮直径代号

突出特点

◆结构先进

1. 结构设计合理，轴承间距短，结构紧凑，整体刚性好，提高运转的稳定性。
2. 具有立卧两种结构，卧式结构左右轴伸互换，可以实现正反向旋转，应用更灵活。
3. 整体密封体及增强型壳体设计，动静密封更可靠。
4. 优化设计的双吸叶轮，双蜗壳结构的壳体，使泵运转时振动及噪音减少到最低。
5. 轴承润滑分为油脂润滑和稀油润滑两种，泵的轴封有填料密封和机械密封，方便用户的选择，可以适用更多的应用场合。
6. 泵的进出口位于同一直线上，管路连接方便。

Model meaning

DMC (DMCL) 100 - 310E (F) G - 1 (2, 3, 4)

DMC — type DMC standard horizontal axially split double suction pump

DMCL — type DMCL standard vertical axially split double suction pump

100 — outlet diameter (mm)

310 — impeller normal diameter (mm)

E (F) — code of impeller hydraulic model

G — motor speed (2900r/min), others omit

1 (2, 3, 4) — code of impeller diameter

Outstanding Features

◆Advanced construction

1. The pump can operate stable by using reasonable construction design, short distance between the bearings, compact size, and good rigidity.
2. Two structure of vertical and horizontal, and horizontal pump can operate in clockwise of anti-clockwise by interchange left and right shaft with more flexible application.
3. This products uses the independent integral sealed parts, solving the problem of dynamic and statics sealing.
4. Optimized double suction impeller, double volute case, keep less vibration and noise.
5. Bearing lubrication has two types: grease or flood oil. Shaft sealing can adopt soft - packed stuffing or mechanical seal, for adopting more applications.
6. Suction and discharge of the pump are inline, convenient for connection of the pipe.

◆水力性能优越

1. 利用先进的计算机辅助软件，结合现代化设计方法对壳体及叶轮进行水力设计，其效率比同类产品平均提高2-5%，而且一个泵体多个叶轮，实现全系列产品保持高效。

2. 型谱范围广，型号划分细致，布局合理。

◆选材精良

1. 选用国际及国内著名品牌精密轴承，特殊设计的机械密封，保证泵运行的低噪音及长寿命。

2. 壳体、叶轮及轴套等主要过流部件有多种不同的材料组合，以满足不同的使用条件。

◆Excellent hydraulic performance

1. Design of hydraulic model of casing and impeller adopts modern design methods by using advanced CAD software. It is 2-5 percent higher than the efficiency of the same pump. It keeps high efficiency of full series by multi-impeller suitable for one casing.

2. Wide range charts, detail type classification, reasonable arrangement.

◆Excellent material

1. Imported domestic famous brand bearing of high quality, special designed mechanical seal ensure lower noise and longer operation life.

2. Multy materials can be used in pump casing, impeller and shaft, so it can suitable for different application.

主要零件材料表 Materials of main parts

| 零件名称 Parts name | 材 料 Materials | | | |
|-------------------------|---------------|--------------|------------|------------------|
| | I | II | | III |
| 泵壳 casing | HT250 | QT400-18 | | ZG230-450 |
| 轴 shaft | 45 | 3Cr13 | | 3Cr13 |
| 叶轮 impeller | HT250 | ZCuSn10Zn2 | ZCuZn16Si4 | ZG1Cr18Ni12Mo2Ti |
| 轴套 sealing shaft sleeve | 45 | 3Cr13 | | Cr18Ni12Mo2Ti |
| 壳体密封环 case sealing ring | HT250 | ZCuSn5Pb5Zn5 | ZCuSn10Zn2 | ZG1Cr18Ni12Mo2Ti |

可以根据用户要求选用其它材料 Other materials can be chosen by orders.

型谱图 Characteristics

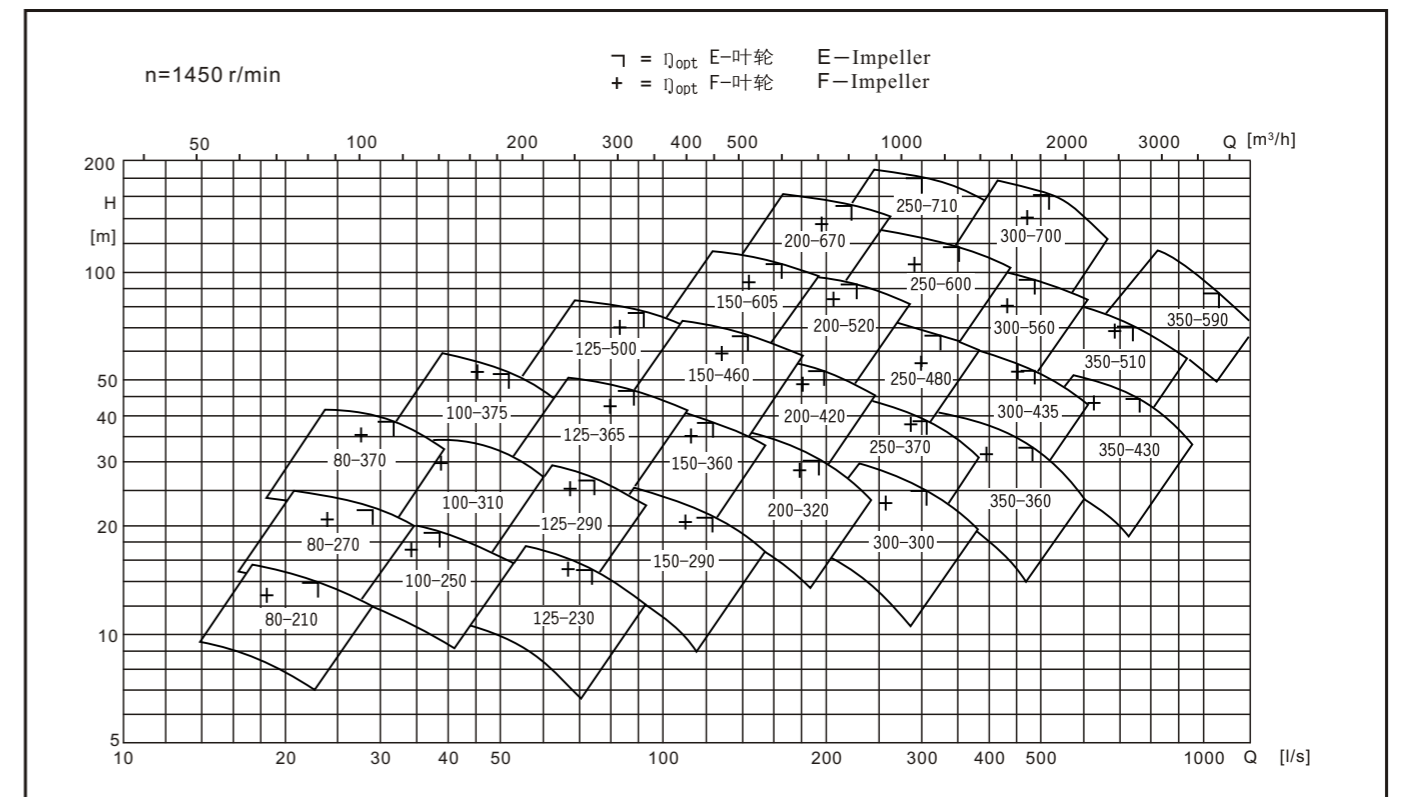
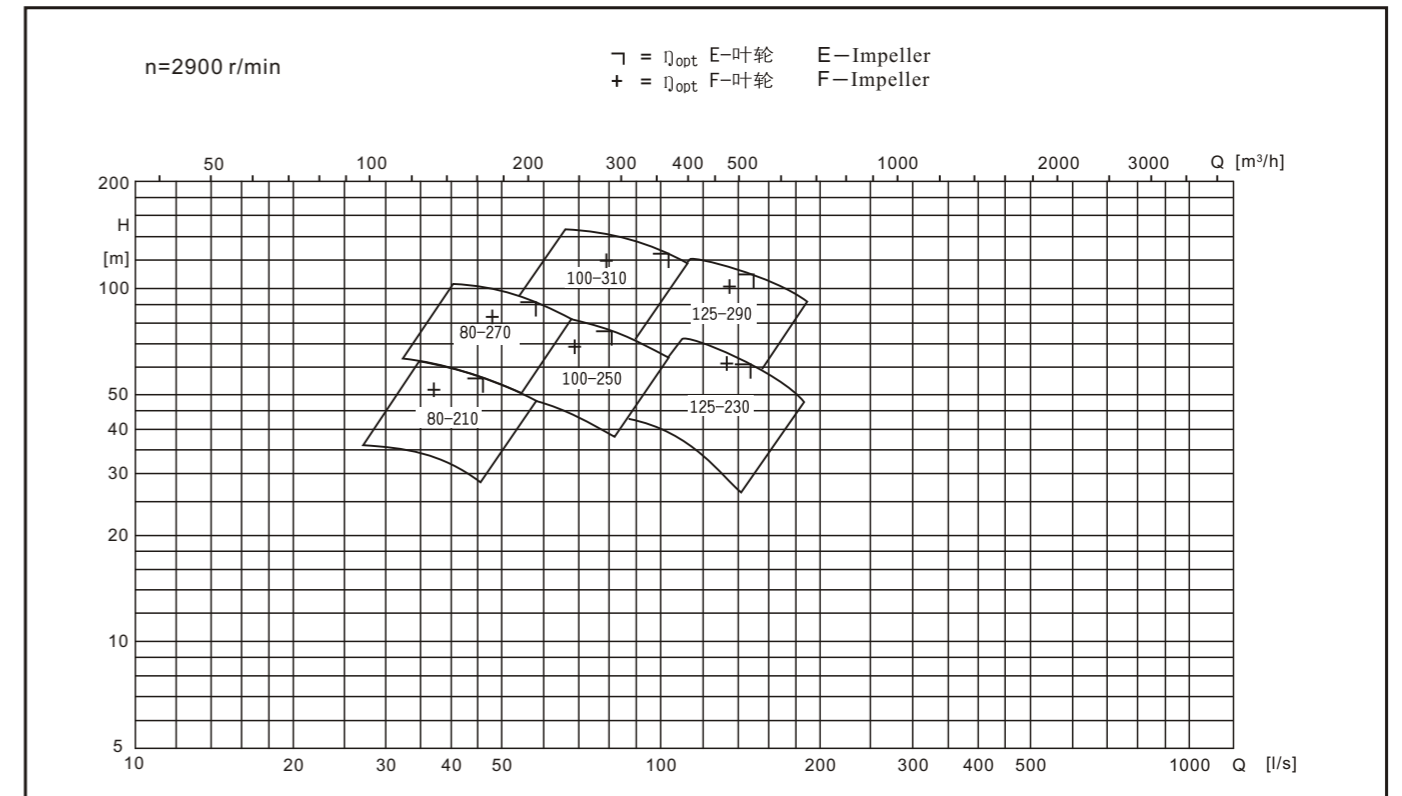

注：可根据要求设计及提供超出标准性能范围的产品。Other performance pumps can be designed by orders

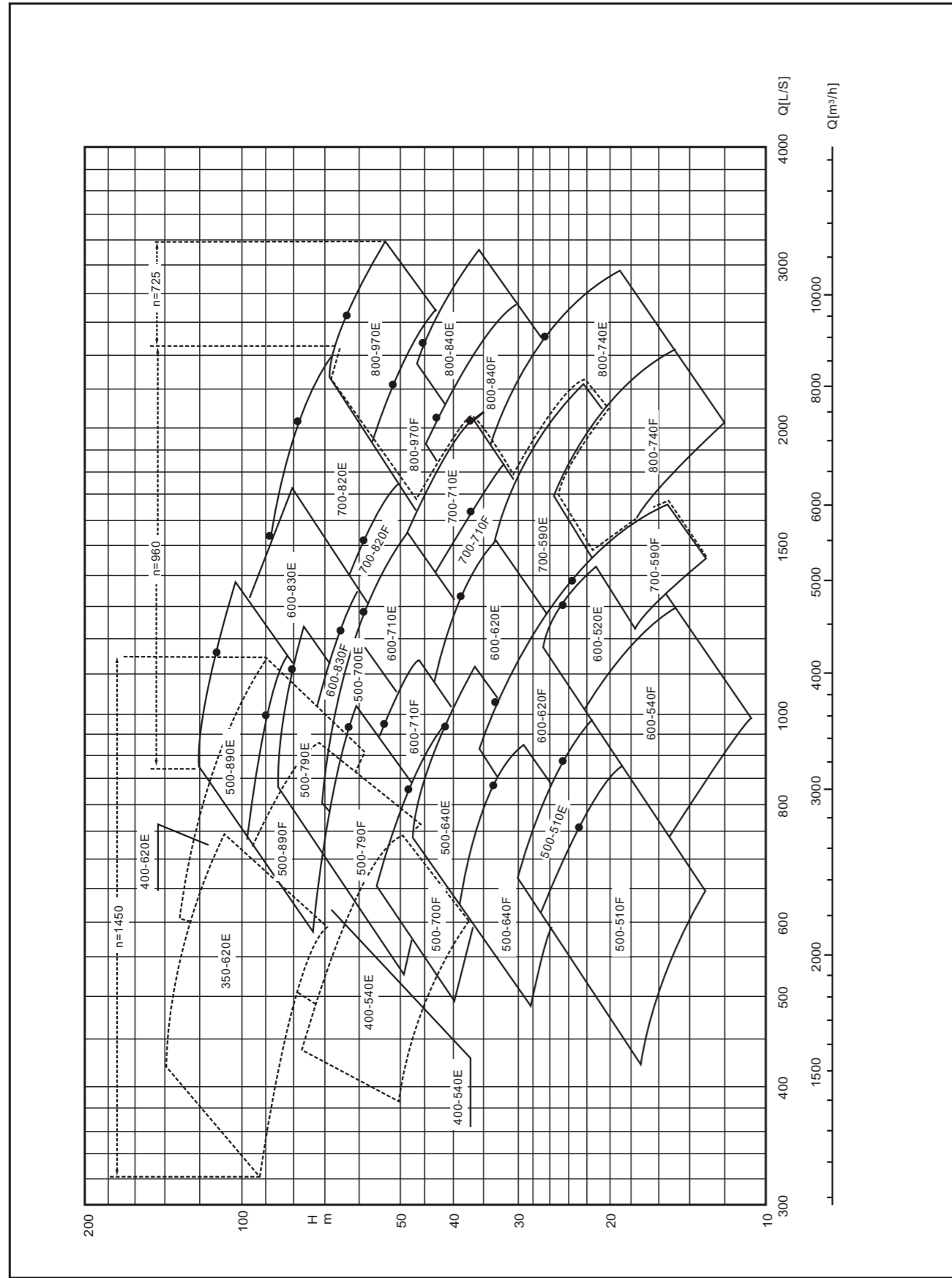

CMD型卧式泵结构图 Construction of DMC pumps

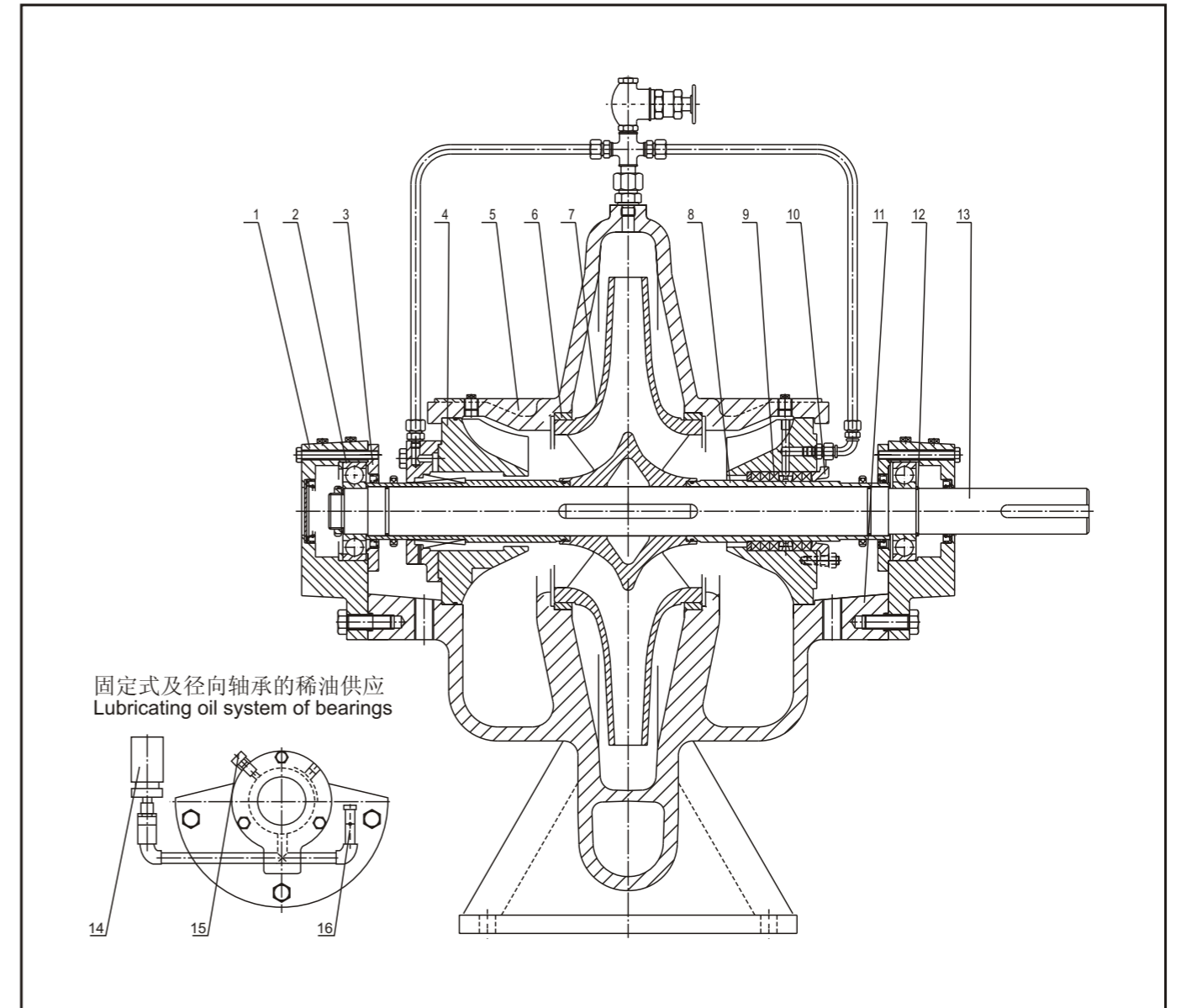

| 序号 No. | 零件名称 part name | 序号 No. | 零件名称 part name | 序号 No. | 零件名称 part name | 序号 No. | 零件名称 part name |
|-----------|-----------------------|-----------|------------------------------|-----------|---------------------------------------|-----------|---------------------|
| 1 | 轴承体 bearing body | 5 | 泵盖 pump cover | 9 | 填料或机械密封 packing or mechanical seal | 13 | 轴 shaft |
| | 轴承 bearing | | 壳体密封环 case sealing ring | | 密封压盖 sealing cover | | 油位计 oil location |
| 2 | 轴承压盖 bearing cover | 6 | 叶轮 impeller | 10 | 泵体 pump casing | 11 | 放气塞 air vent |
| | 密封体 sealing body | | 密封轴套 sealing shaft sleeve | | 弹性挡圈 block ring | | 示油器 oil mark |

DMCL型立式泵结构图 Construction of CMDV pumps (CMD80-210~CMD350-510)

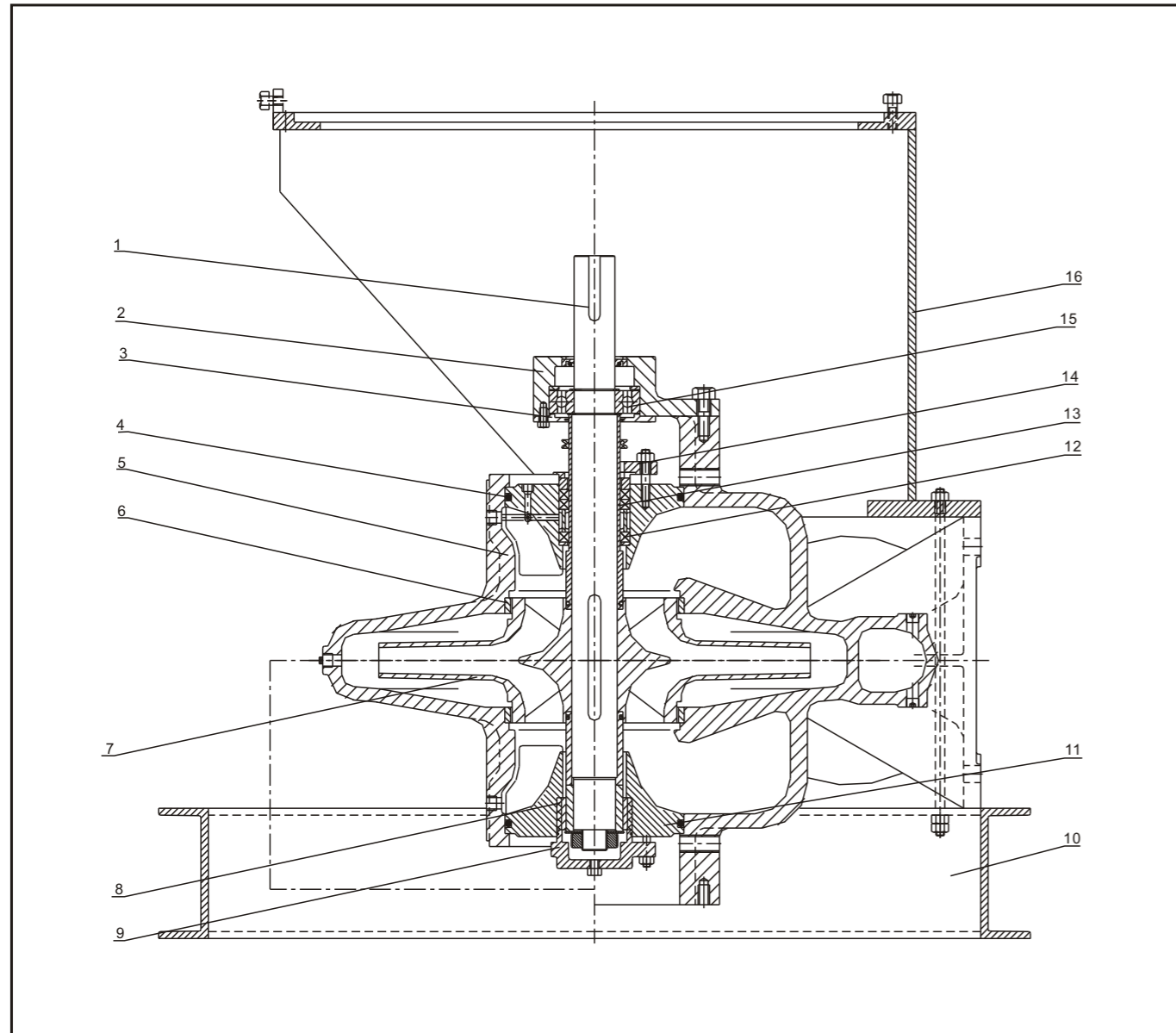

| 序号 No. | 零件名称 part name | 序号 No. | 零件名称 part name | 序号 No. | 零件名称 part name | 序号 No. | 零件名称 part name |
|-----------|-----------------------|-----------|----------------------------|-----------|---------------------------------------|-----------|-----------------------------|
| 1 | 轴 shaft | 5 | 泵壳 casing | 9 | 导轴承压盖 guild bearing cover | 13 | 密封轴套 sealingshaft sleeve |
| 2 | 轴承体 bearing body | 6 | 壳体密封环 case sealing ring | 10 | 底座 baseplate | 14 | 密封压盖 sealing cover |
| 3 | 轴承压盖 bearing cover | 7 | 叶轮 impeller | 11 | 密封体 sealing body | 15 | 轴承 bearing |
| 4 | 密封圈 sealing ring | 8 | 导轴承 guild bearing | 12 | 填料或机械密封 packing or mechanical seal | 16 | 电机座 motor plate |

卧式 horizontal

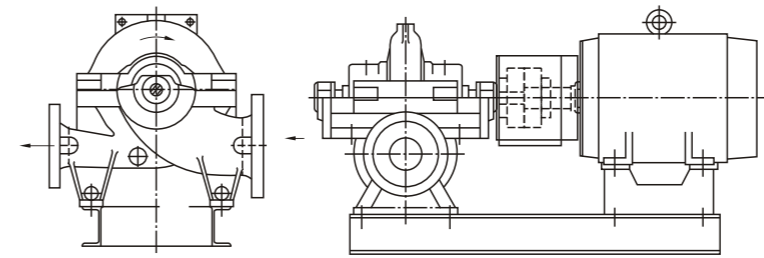

立式 vertical

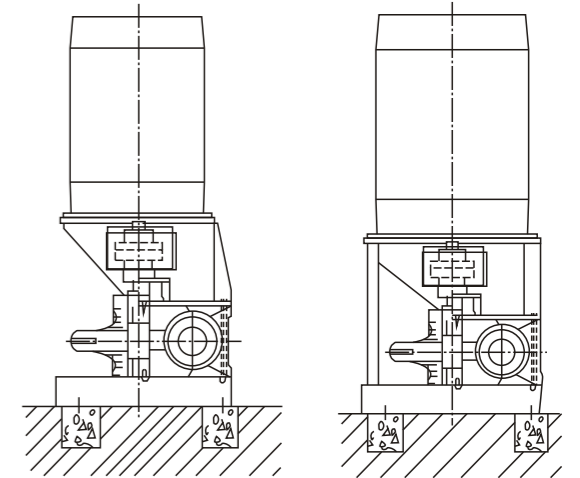

密封水管路布置 Pipe system for sealing water

填料密封冲洗水管路
flushing system for packing

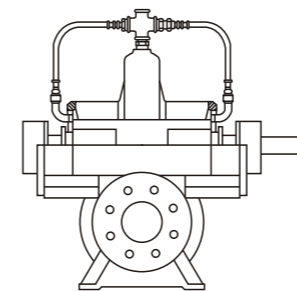

机械密封冲洗水管路
flushing system for mechanical seal

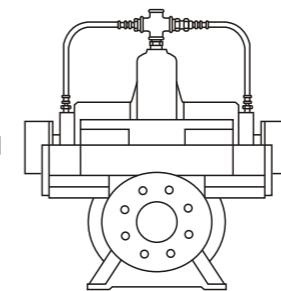

填料密封及导轴承的冲洗水管路
flushing system for packing and guide bearing

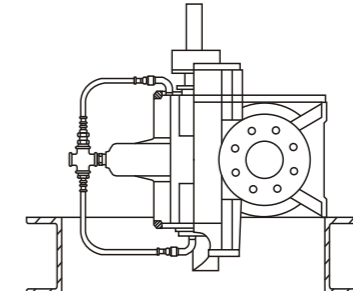

机械密封及导轴承的冲洗水管路
flushing system for mechanical seal and guide bearing

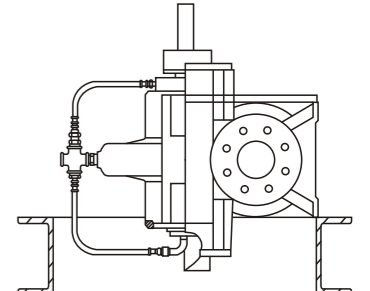

转向/流向 rotating direction/flow direction

卧式 horizontal

从传动端看
逆时针方向旋转
anti-clockwise

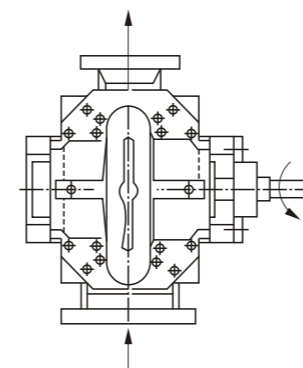

从传动端看
顺时针方向旋转
clockwise

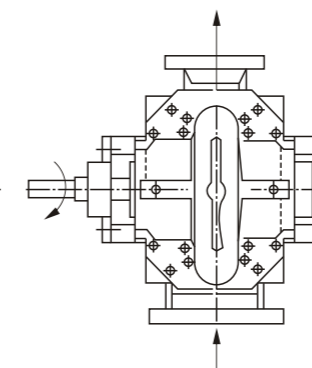

立式 vertical

从传动端看
逆时针方向旋转
anti-clockwise

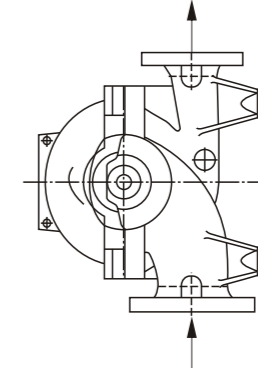

从传动端看
顺时针方向旋转
clockwise

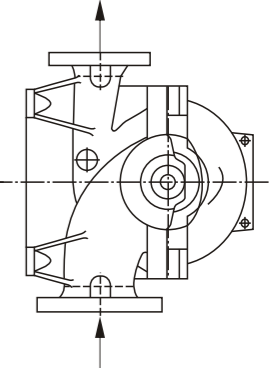

DMC80-210 EG Curve n=2900r/min

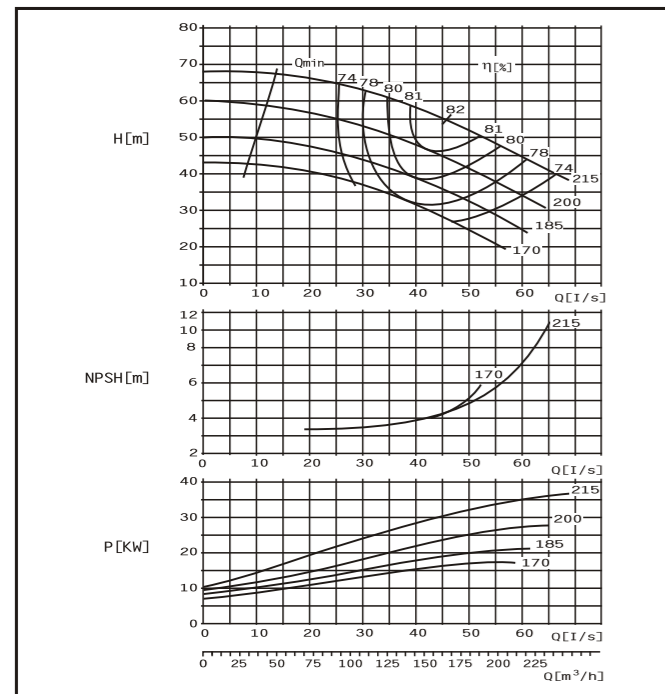

DMC80-210 FG Curve n=2900r/min

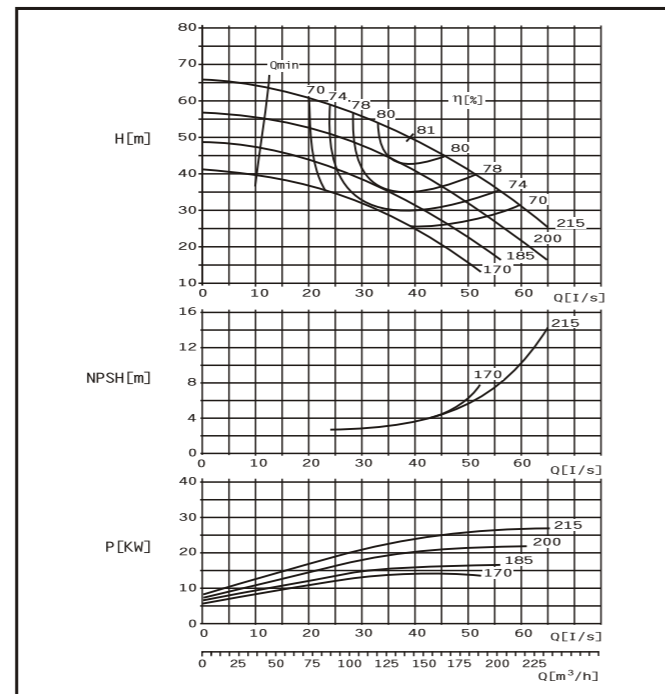

DMC卧式泵安装尺寸图 Installing dimensions of DMC pumps

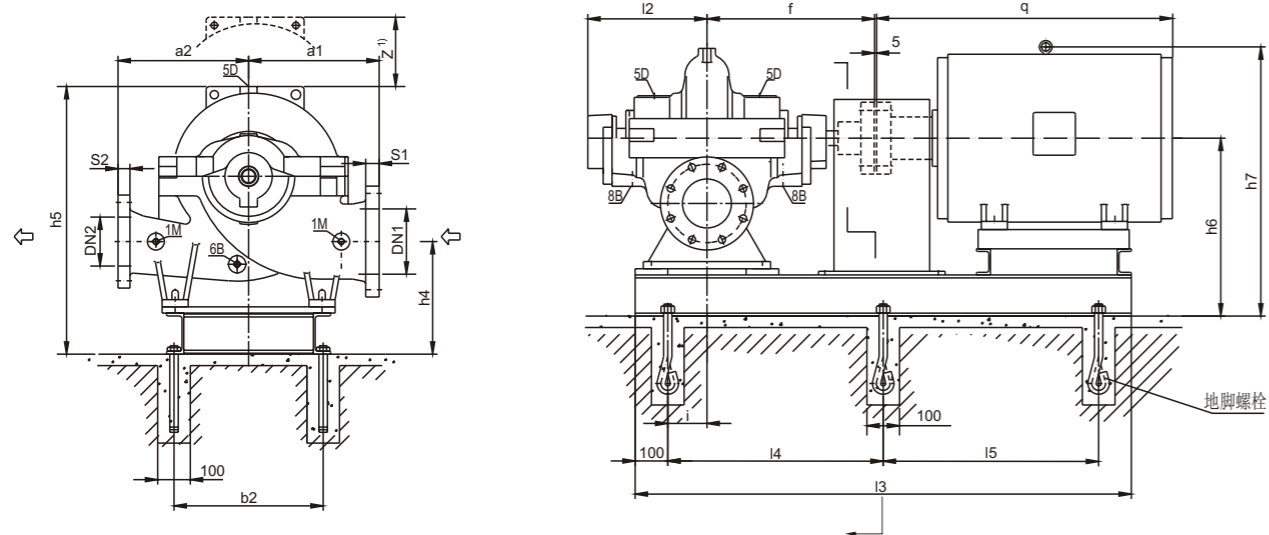

连接尺寸 connection dimensions:

- 1M 压力表Rp1/2 1M pressure gauge Rp1/2
- 6B 排液孔Rp1/2 6B drain plug Rp1/2
- 5D 排气孔Rp1/2 5D air vent Rp1/2
- 8B 漏液排出孔Rp3/4 8B drain plug Rp3/4

Z¹⁾ 拆卸转子所需最小空间尺寸

Z¹⁾ Min. dimensions of disassembling rotor assembly

法兰钻孔示意图

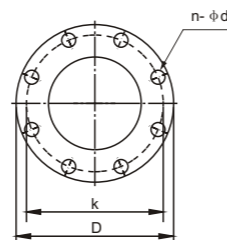

DMC80-270 EG Curve n=2900r/min

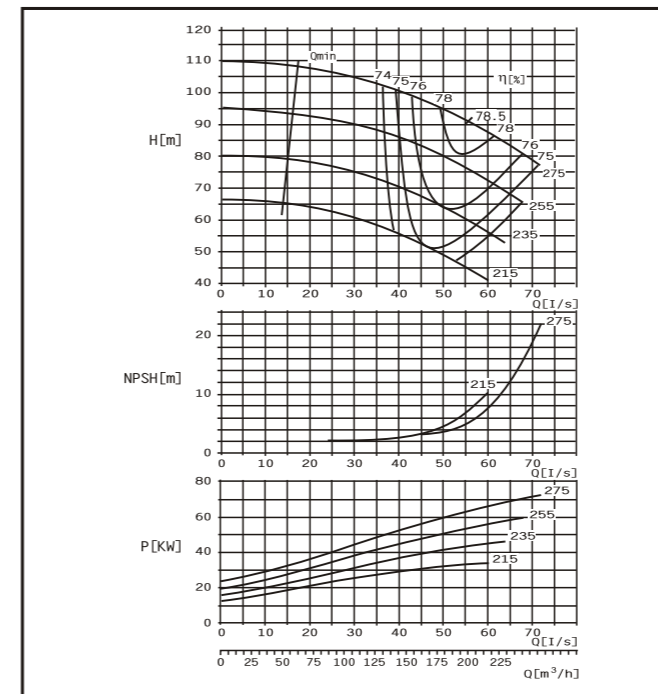

DMC80-270 FG Curve n=2900r/min

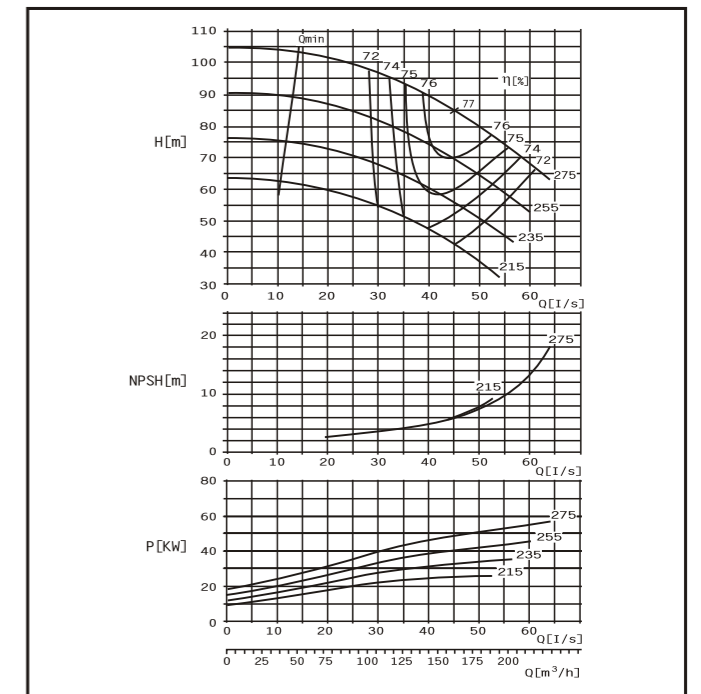

参数表 Performance table

| 泵型号 Type | 流量 Capacity Q | 扬程 Head m | 转速 Speed r/min | 轴功率 Shaft power kW | 效率 eff η % | 有效汽 蚀余量 NPSHa m | 电机功率 Motor power kW | 叶轮参 考直径 D(mm) | | | |
|-----------------|---------------------|-----------------|----------------------|-----------------------------|------------------|--------------------------|------------------------------|---------------------|-----|----|-----|
| DMC 80-210EG | 131 | 36.4 | 60.5 | 26.8 | 80.6 | 5.1 | 37 | 215 | | | |
| | 164 | 45.6 | 55 | 29.9 | 82.0 | | | | | | |
| | 197 | 54.6 | 50 | 33.4 | 80.2 | | | | | | |
| | 121 | 33.6 | 52 | 21.6 | 79.3 | | | | | | |
| | 151 | 42 | 47.5 | 24.1 | 81.0 | | | | | | |
| | 181 | 50.4 | 42.2 | 26.1 | 80 | | | | | | |
| DMC 80-210FG | 110 | 30.6 | 37 | 14.7 | 75.3 | 4.3 | 18.5 | 170 | | | |
| | 137 | 38 | 33.5 | 16 | 77.8 | | | | | | |
| | 164 | 45.6 | 27.7 | 16.7 | 74 | | | | | | |
| | 107 | 29.7 | 55.5 | 20.5 | 79 | | | | | | |
| | 134 | 37.1 | 51 | 22.9 | 81 | | | | | | |
| | 160 | 44.5 | 46 | 25.1 | 80.1 | | | | | | |
| DMC 80-270EG | 147 | 40.8 | 70 | 37.5 | 74.7 | 4.6 | 30 | 200 | | | |
| | 184 | 51 | 63.5 | 41.8 | 76 | | | | | | |
| | 220 | 61.2 | 55 | 44.6 | 74 | | | | | | |
| | 156 | 43.2 | 83.5 | 46.6 | 76 | | | | | | |
| | 194 | 54 | 77 | 52.6 | 77.5 | | | | | | |
| | 233 | 64.8 | 69 | 58.1 | 75.5 | | | | | | |
| DMC 80-270FG | 137 | 38 | 91 | 44.6 | 76.1 | 5.3 | 55 | 235 | | | |
| | 171 | 47.5 | 82.5 | 49.9 | 77 | | | | | | |
| | 205 | 57 | 72.5 | 54.1 | 75 | | | | | | |
| | 138 | 38.4 | 56.5 | 28.7 | 74.2 | | | | 5.0 | 37 | 215 |
| | 173 | 48 | 50 | 31.4 | 75 | | | | | | |
| | 198 | 55 | 45 | 32.8 | 74 | | | | | | |
| 107 | 29.7 | 55.5 | 35.6 | 74.4 | | | | | | | |
| 153 | 42.5 | 47.7 | 39 | 76.2 | | | | | | | |
| 184 | 51 | 67 | 44.7 | 76 | | | | | | | |
| DMC 80-270EG | 115 | 31.9 | 66.8 | 28.5 | 73.7 | 5.5 | 37 | 235 | | | |
| | 144 | 40 | 60 | 31.3 | 75.2 | | | | | | |
| | 173 | 48.1 | 53 | 33.7 | 74.2 | | | | | | |
| | 110 | 30.6 | 54.5 | 22.4 | 72.5 | | | | 5.4 | 30 | 215 |
| | 137 | 38.1 | 44 | 24.5 | 74.4 | | | | | | |
| | 164 | 45.6 | 42 | 25.9 | 72.5 | | | | | | |

参数表 Performance table

| 泵型号 Type | 流量 Capacity Q | 扬程 Head m | 转速 Speed r/min | 轴功率 Shaft power kW | 效率 eff η % | 有效汽 蚀余量 NPSHa m | 电机功率 Motor power kW | 叶轮参 考直径 D(mm) | | | |
|-----------------|---------------------|-----------------|----------------------|-----------------------------|------------------|--------------------------|------------------------------|---------------------|-----|----|-----|
| DMC 80-210EG | 131 | 36.4 | 60.5 | 26.8 | 80.6 | 5.1 | 37 | 215 | | | |
| | 164 | 45.6 | 55 | 29.9 | 82.0 | | | | | | |
| | 197 | 54.6 | 50 | 33.4 | 80.2 | | | | | | |
| | 121 | 33.6 | 52 | 21.6 | 79.3 | | | | | | |
| | 151 | 42 | 47.5 | 24.1 | 81.0 | | | | | | |
| | 181 | 50.4 | 42.2 | 26.1 | 80 | | | | | | |
| DMC 80-210FG | 110 | 30.6 | 37 | 14.7 | 75.3 | 4.3 | 18.5 | 170 | | | |
| | 137 | 38 | 33.5 | 16 | 77.8 | | | | | | |
| | 164 | 45.6 | 27.7 | 16.7 | 74 | | | | | | |
| | 107 | 29.7 | 55.5 | 20.5 | 79 | | | | | | |
| | 134 | 37.1 | 51 | 22.9 | 81 | | | | | | |
| | 160 | 44.5 | 46 | 25.1 | 80.1 | | | | | | |
| DMC 80-270EG | 147 | 40.8 | 70 | 37.5 | 74.7 | 4.6 | 30 | 200 | | | |
| | 184 | 51 | 63.5 | 41.8 | 76 | | | | | | |
| | 220 | 61.2 | 55 | 44.6 | 74 | | | | | | |
| | 156 | 43.2 | 83.5 | 46.6 | 76 | | | | | | |
| | 194 | 54 | 77 | 52.6 | 77.5 | | | | | | |
| | 233 | 64.8 | 69 | 58.1 | 75.5 | | | | | | |
| DMC 80-270FG | 137 | 38 | 91 | 44.6 | 76.1 | 5.3 | 55 | 235 | | | |
| | 171 | 47.5 | 82.5 | 49.9 | 77 | | | | | | |
| | 205 | 57 | 72.5 | 54.1 | 75 | | | | | | |
| | 138 | 38.4 | 56.5 | 28.7 | 74.2 | | | | 5.0 | 37 | 215 |
| | 173 | 48 | 50 | 31.4 | 75 | | | | | | |
| | 198 | 55 | 45 | 32.8 | 74 | | | | | | |
| 107 | 29.7 | 55.5 | 35.6 | 74.4 | | | | | | | |
| 153 | 42.5 | 47.7 | 39 | 76.2 | | | | | | | |
| 184 | 51 | 67 | 44.7 | 76 | | | | | | | |
| DMC 80-270EG | 115 | 31.9 | 66.8 | 28.5 | 73.7 | 5.5 | 37 | 235 | | | |
| | 144 | 40 | 60 | 31.3 | 75.2 | | | | | | |
| | 173 | 48.1 | 53 | 33.7 | 74.2 | | | | | | |
| | 110 | 30.6 | 54.5 | 22.4 | 72.5 | | | | 5.4 | 30 | 215 |
| | 137 | 38.1 | 44 | 24.5 | 74.4 | | | | | | |
| | 164 | 45.6 | 42 | 25.9 | 72.5 | | | | | | |

主要外型尺寸 pump outline size

| 泵型号 type | 法兰尺寸 flange size | | | | | | | | 泵尺寸 pump size | | | | | 泵重量W.T | | | | |
|-------------|-------------------|----|-----|-----|--------------------|-----|----|-----|---------------|---------|-----|-----|-----|-----------------|-------|-------|-----|-----|
| | 进口法兰 inlet flange | | | | 出口法兰 outlet flange | | | | a1 | a2 | f | h5≤ | 12 | z ¹⁾ | 净重N.T | 湿重G.T | | |
| | DN1 | S1 | K | D | n-φd | DN2 | S2 | K | D | n-φd | | | | | | | | |
| 80-210 | 125 | 26 | 210 | 250 | 8-φ17.5 | 80 | 24 | 160 | 200 | 8-φ17.5 | 300 | 300 | 385 | 660 | 300 | 340 | 185 | 195 |
| 80-270 | | | | | | | | | | | | | | | | 380 | 195 | 210 |

电机尺寸——Y型电机 Motor size(2极)

| 泵型号 Type | 电机Motor | | b2 | h4 | h6 | h7 | l3 | l4 | l5 | i | q | 电机重量(kg) Motor W · T | 底座参考 重量(kg) Baseplate W · T | 地脚螺栓 anchor bolt | | | | |
|-------------|---------|-----------------|-------|-----|------|-----|------|------|-----|----|-----|-------------------------|-----------------------------------|---------------------|------|-----|-----|-----|
| | 型号 Type | 功率Power (kW) | | | | | | | | | | | | | | | | |
| 80-270 | 80-210 | 160M2 | 15 | 340 | 295 | 435 | 660 | 1050 | 425 | 70 | 605 | 132 | 70 | 6- M16×350 | | | | |
| | | 160L | 18.5 | | | | | | | | 650 | 150 | | | | | | |
| | | 180M | 22 | | | | | | | | 670 | 182 | | | | | | |
| | | 200L | 30/37 | | | | | | | | 710 | 1190 | | | 495 | 775 | 255 | |
| | | 225M | 45 | | | | | | | | 356 | 765 | | | 1230 | 515 | 815 | 308 |
| | | 250M | 55 | | | | | | | | 406 | 785 | | | 1320 | 560 | 930 | 403 |
| | 280S | 75 | 457 | 820 | 1390 | 595 | 1000 | 544 | 140 | | | | | | | | | |

DMC100-250 EG Curve n=2900r/min

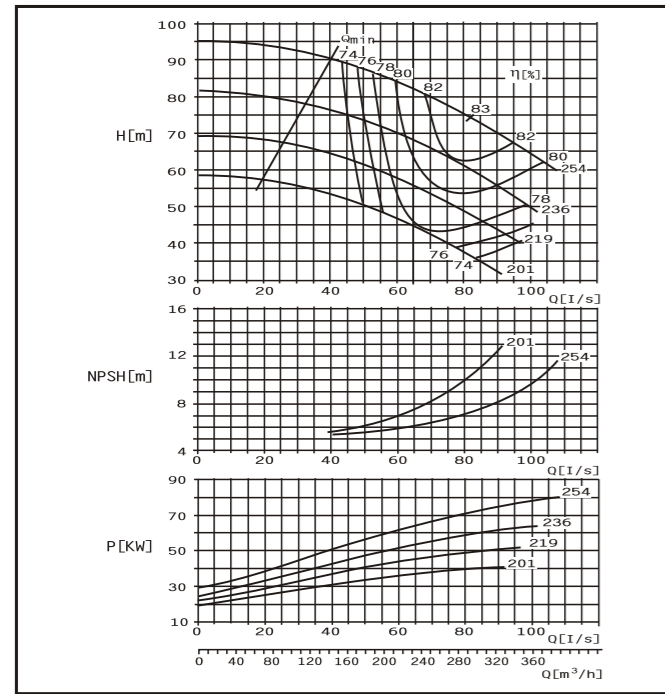

DMC100-250 FG Curve n=2900r/min

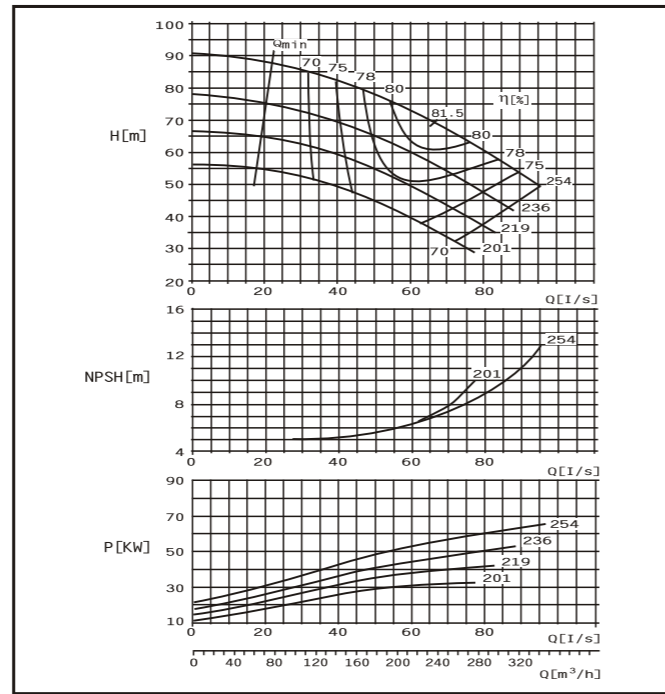

DMC卧式泵安装尺寸图 Installing dimensions of CMD pumps

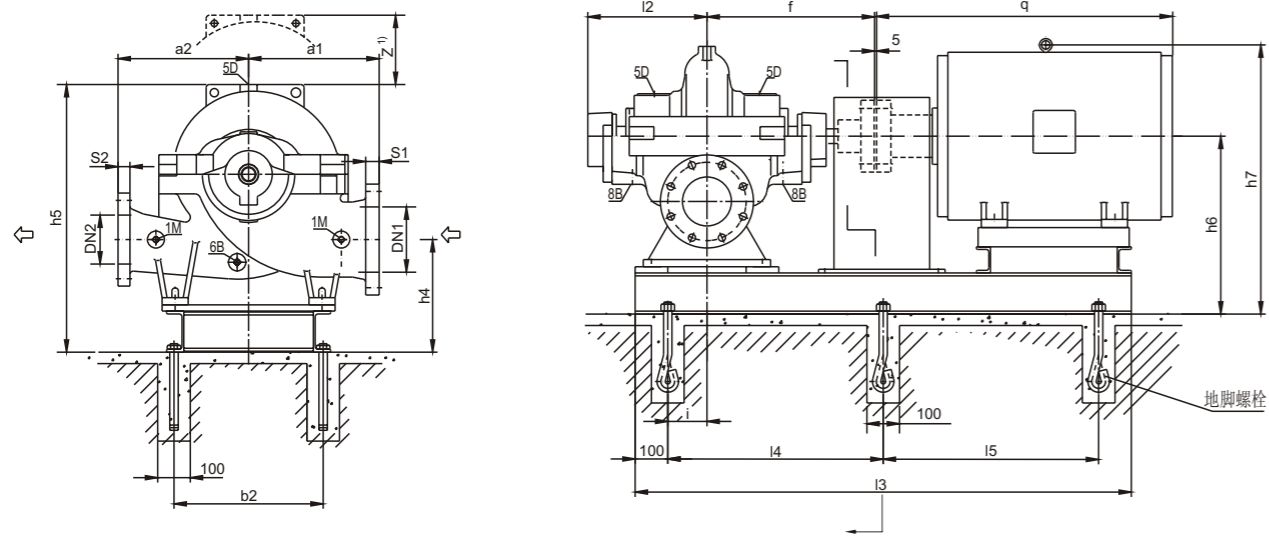

连接尺寸 connection dimensions:

- 1M 压力表Rp1/2 1M pressure gauge Rp1/2
- 6B 排液孔Rp1/2 6B drain plug Rp1/2
- 5D 排气孔Rp1/2 5D air vent Rp1/2
- 8B 漏液排出孔Rp3/4 8B drain plug Rp3/4

Z¹⁾ 拆卸转子所需最小空间尺寸

Z¹⁾ Min. dimensions of disassembling rotor assembly

法兰钻孔示意图

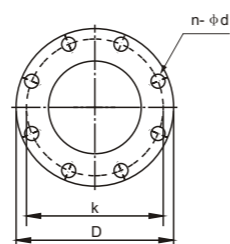

DMC100-310 EG Curve n=2900r/min

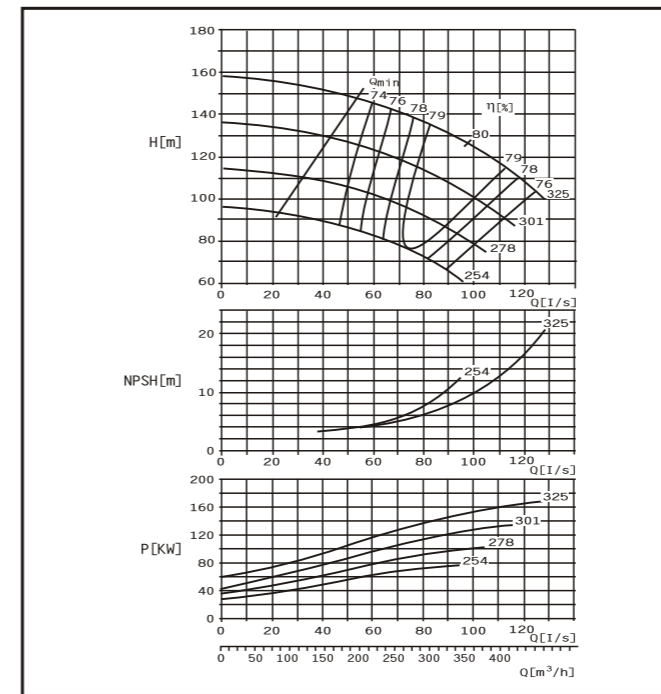

DMC100-310 FG Curve n=2900r/min

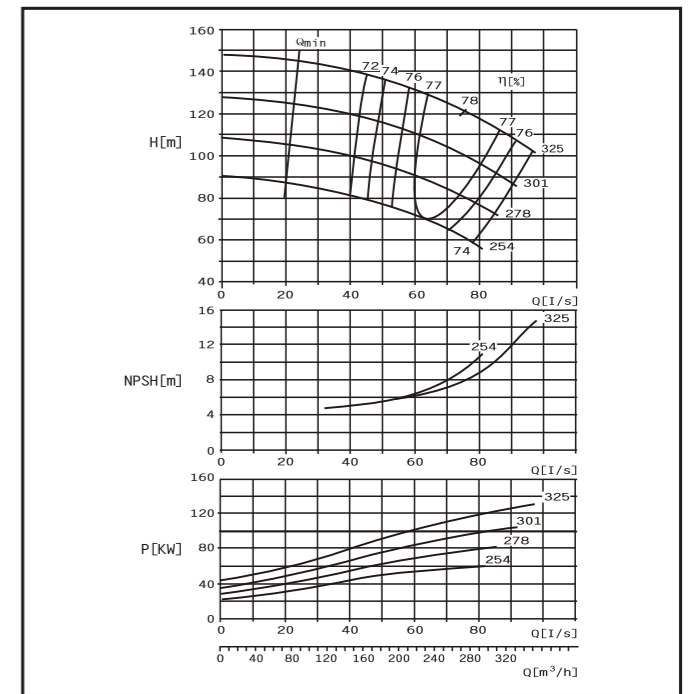

参数表 Performance table

| 泵型号 Type | 流量 Capacity Q | 扬程 Head m | 转速 Speed r/min | 轴功率 Shaft power kW | 效率 eff η % | 有效汽 蚀余量 NPSHa m | 电机功率 Motor power kW | 叶轮参 考直径 D(mm) |
|------------------|---------------------|-----------------|----------------------|-----------------------------|------------------|--------------------------|------------------------------|---------------------|
| DMC 100-250EG | 230 | 64 | 83 | 64.2 | 80.7 | 9.0 | 90 | 254 |
| | 288 | 80 | 75 | 70.9 | 83 | | | |
| | 346 | 96 | 67 | 78.4 | 80.5 | | | |
| | 219 | 60.8 | 69 | 51.9 | 79.3 | | | |
| | 274 | 76 | 63 | 58.3 | 80.5 | | | |
| | 328 | 91.2 | 55 | 62.3 | 79 | | | |
| DMC 100-250FG | 209 | 58 | 59 | 43.5 | 77.2 | 9.7 | 55 | 219 |
| | 261 | 72.5 | 52 | 46.8 | 79 | | | |
| | 313 | 87 | 46.5 | 51.5 | 77 | | | |
| | 193 | 53.6 | 49 | 33.9 | 78 | | | |
| | 240 | 66.7 | 45 | 37.7 | 78 | | | |
| | 290 | 80.6 | 37 | 39.2 | 74.5 | | | |
| DMC 100-310EG | 294 | 81.6 | 135 | 137.7 | 78.5 | 13.7 | 185 | 325 |
| | 367 | 102 | 123 | 153.6 | 80 | | | |
| | 440 | 122.2 | 105 | 164 | 76.8 | | | |
| | 268 | 74.4 | 116 | 108 | 78.3 | | | |
| | 335 | 93 | 106 | 121.4 | 79.6 | | | |
| | 402 | 111.7 | 92 | 131 | 77 | | | |
| DMC 100-310FG | 242 | 67.2 | 98 | 82.7 | 78.1 | 10.7 | 110 | 278 |
| | 302 | 83.9 | 90 | 93.5 | 79.3 | | | |
| | 363 | 100.8 | 80 | 102.5 | 77.2 | | | |
| | 182 | 50.5 | 82 | 52.8 | 77 | | | |
| | 227 | 66.7 | 74 | 70.7 | 78.3 | | | |
| | 333 | 92.4 | 65.5 | 77 | 76 | | | |
| DMC 100-250EG | 196 | 54.4 | 75 | 50 | 80 | 8.6 | 75 | 254 |
| | 245 | 68 | 68 | 55.6 | 81.5 | | | |
| | 294 | 81.6 | 59 | 59.8 | 79 | | | |
| | 180 | 50 | 65 | 40.6 | 78 | | | |
| | 223 | 62 | 59 | 44.7 | 79.5 | | | |
| | 268 | 74.4 | 51 | 47.9 | 77 | | | |
| DMC 100-310EG | 208 | 57.8 | 111 | 81.8 | 76.3 | 9.5 | 110 | 301 |
| | 260 | 72.2 | 103 | 89 | 77.6 | | | |
| | 310 | 86.1 | 90 | 93.7 | 76 | | | |
| | 200 | 55.6 | 92 | 65.8 | 76.1 | | | |
| | 250 | 69.3 | 84 | 73.8 | 77.3 | | | |
| | 300 | 83.3 | 74 | 80.5 | 75 | | | |
| DMC 100-250EG | 150 | 41.7 | 48 | 26.4 | 75 | 7.1 | 37 | 201 |
| | 190 | 52.8 | 43 | 29.1 | 76 | | | |
| | 227 | 63 | 38 | 31.1 | 75.5 | | | |

参数表 Performance table

| 泵型号 Type | 流量 Capacity Q | 扬程 Head m | 转速 Speed r/min | 轴功率 Shaft power kW | 效率 eff η % | 有效汽 蚀余量 NPSHa m | 电机功率 Motor power kW | 叶轮参 考直径 D(mm) |
|------------------|---------------------|-----------------|----------------------|-----------------------------|------------------|--------------------------|------------------------------|---------------------|
| DMC 100-250EG | 294 | 81.6 | 135 | 137.7 | 78.5 | 13.7 | 185 | 325 |
| | 367 | 102 | 123 | 153.6 | 80 | | | |
| | 440 | 122.2 | 105 | 164 | 76.8 | | | |
| | 268 | 74.4 | 116 | 108 | 78.3 | | | |
| | 335 | 93 | 106 | 121.4 | 79.6 | | | |
| | 402 | 111.7 | 92 | 131 | 77 | | | |
| DMC 100-310EG | 242 | 67.2 | 98 | 82.7 | 78.1 | 10.7 | 110 | 278 |
| | 302 | 83.9 | 90 | 93.5 | 79.3 | | | |
| | 363 | 100.8 | 80 | 102.5 | 77.2 | | | |
| | 182 | 50.5 | 82 | 52.8 | 77 | | | |
| | 227 | 66.7 | 74 | 70.7 | 78.3 | | | |
| | 333 | 92.4 | 65.5 | 77 | 76 | | | |
| DMC 100-250FG | 196 | 54.4 | 75 | 50 | 80 | 8.6 | 75 | 254 |
| | 245 | 68 | 68 | 55.6 | 81.5 | | | |
| | 294 | 81.6 | 59 | 59.8 | 79 | | | |
| | 180 | 50 | 65 | 40.6 | 78 | | | |
| | 223 | 62 | 59 | 44.7 | 79.5 | | | |
| | 268 | 74.4 | 51 | 47.9 | 77 | | | |
| DMC 100-310FG | 208 | 57.8 | 111 | 81.8 | 76.3 | 9.5 | 110 | 301 |
| | 260 | 72.2 | 103 | 89 | 77.6 | | | |
| | 310 | 86.1 | 90 | 93.7 | 76 | | | |
| | 200 | 55.6 | 92 | 65.8 | 76.1 | | | |
| | 250 | 69.3 | 84 | 73.8 | 77.3 | | | |
| | 300 | 83.3 | 74 | 80.5 | 75 | | | |
| DMC 100-250EG | 150 | 41.7 | 48 | 26.4 | 75 | 7.1 | 37 | 201 |
| | 190 | 52.8 | 43 | 29.1 | 76 | | | |
| | 227 | 63 | 38 | 31.1 | 75.5 | | | |

主要外型尺寸 pump outline size

| 泵型号 type | 法兰尺寸 flange size | | | | | | 泵尺寸 pump size | | | | | 泵重量W.T | | | | | | |
|-------------|-------------------|----|-----|--------------------|-------|-----|---------------|-----|-----|---------|-----|-----------------|-------|-------|-----|-----|-----|-----|
| | 进口法兰 inlet flange | | | 出口法兰 outlet flange | | | a1 | a2 | f | h5≤ | 12 | z ¹⁾ | 净重N.T | 湿重G.T | | | | |
| 100-250 | DN1 | S1 | K | D | n-φd | DN2 | S2 | K | D | n-φd | 330 | 330 | 385 | 760 | 300 | 390 | 210 | 230 |
| 100-310 | 150 | 28 | 240 | 285 | 8-φ22 | 100 | 24 | 180 | 220 | 8-φ17.5 | | | | | | 450 | 225 | 250 |

电机尺寸——Y型电机 Motor size(2极)

| 泵型号 Type | 电机Motor | | b2 | h4 | h6 | h7 | l3 | l4 | l5 | i | q | 电机重量(kg) Motor W · T | 底座参考 重量(kg) Baseplate W · T | 地脚螺栓 anchor bolt | | | |
|-------------|------------|---------------------|------|---------|-----|-----|-----|------|------|-----|-----|-------------------------|-----------------------------------|---------------------|-----------|------|------|
| | 型号 Type | 功率 Power (kW) | | | | | | | | | | | | | | | |
| 100-310 | 100-250 | 200L | 37 | 400 | 305 | 475 | 750 | 1190 | 495 | 70 | 775 | 255 | 100 | 6-M20×400 | | | |
| | | 225M | 45 | | | | | | | | | | | | 815 | 308 | |
| | | 250M | 55 | | | | | | | | | | | | 825 | 403 | |
| | | 280S | 75 | | | | | | | | | | | | 860 | 544 | |
| | | 280M | 90 | | | | | | | | | | | | 860 | 577 | |
| | | 315S | 110 | | | | | | | | | | | | 1050 | 980 | |
| | 100-310 | 100-310 | 315M | 132 | 508 | 330 | 500 | 860 | 1390 | 595 | 85 | 1000 | 544 | 140 | 6-M20×400 | | |
| | | | 315L | 160/185 | | | | | | | | | | | | 1440 | 620 |
| | | | | | | | | | | | | | | | | 1480 | 640 |
| | | | | | | | | | | | | | | | | 1530 | 665 |
| | | | | | | | | | | | | | | | | 1560 | 680 |
| | | | | | | | | | | | | | | | | 1310 | 1220 |

DMC125-230 EG Curve n=2900r/min

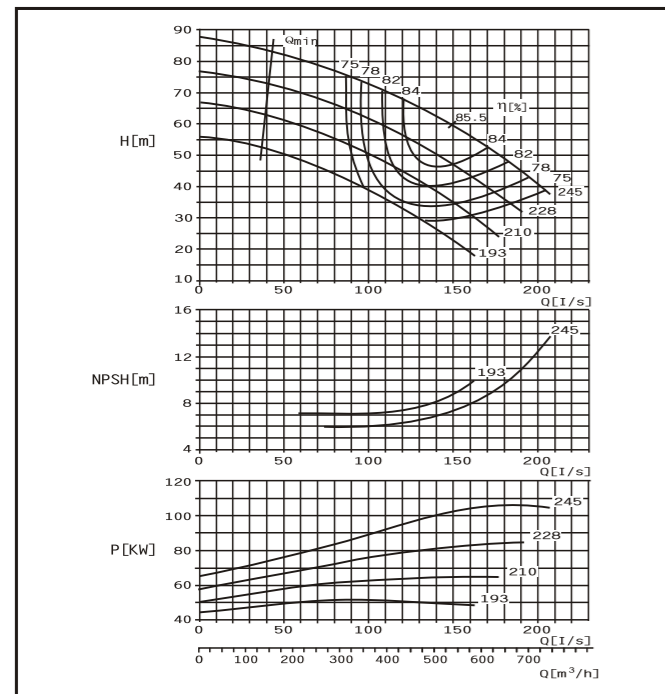

DMC125-230 FG Curve n=2900r/min

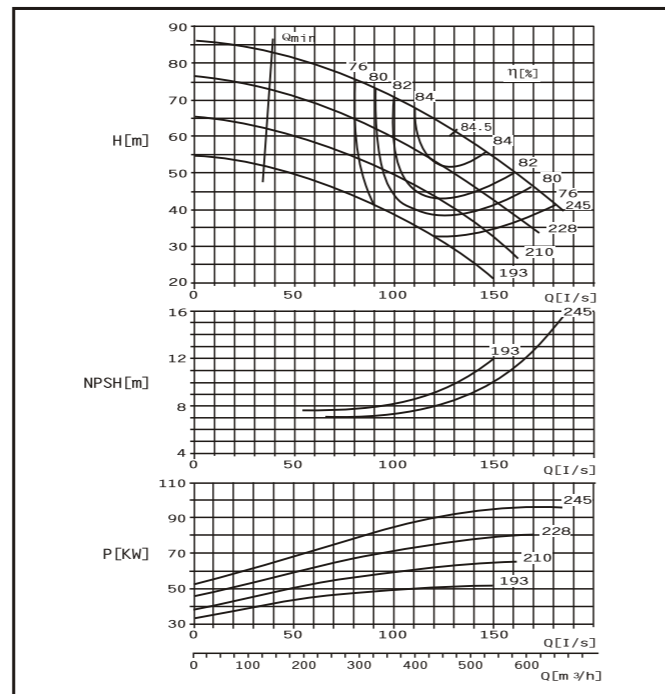

DMC卧式泵安装尺寸图 Installing dimensions of DMC pumps

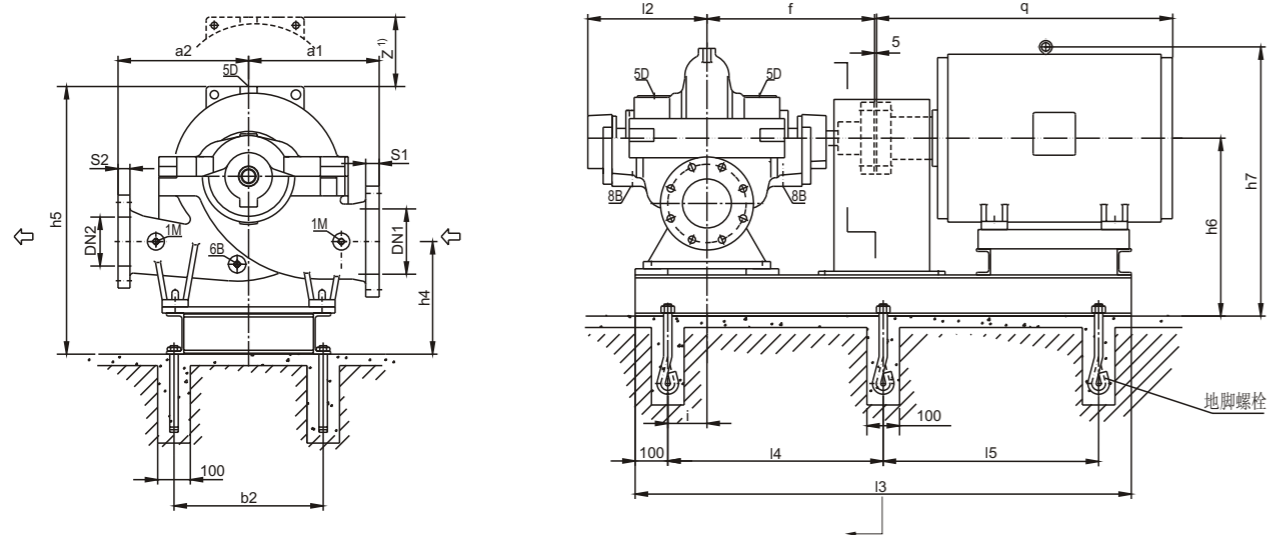

连接尺寸 connection dimensions:

- 1M 压力表Rp1/2 1M pressure gauge Rp1/2
- 6B 排液孔Rp1/2 6B drain plug Rp1/2
- 5D 排气孔Rp1/2 5D air vent Rp1/2
- 8B 漏液排出孔Rp3/4 8B drain plug Rp3/4

Z¹) 拆卸转子所需最小空间尺寸

Z¹) Min. dimensions of disassembling rotor assembly

法兰钻孔示意图

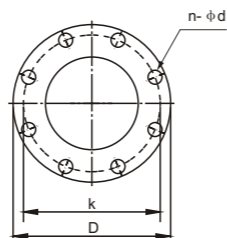

DMC125-290 EG Curve n=2900r/min

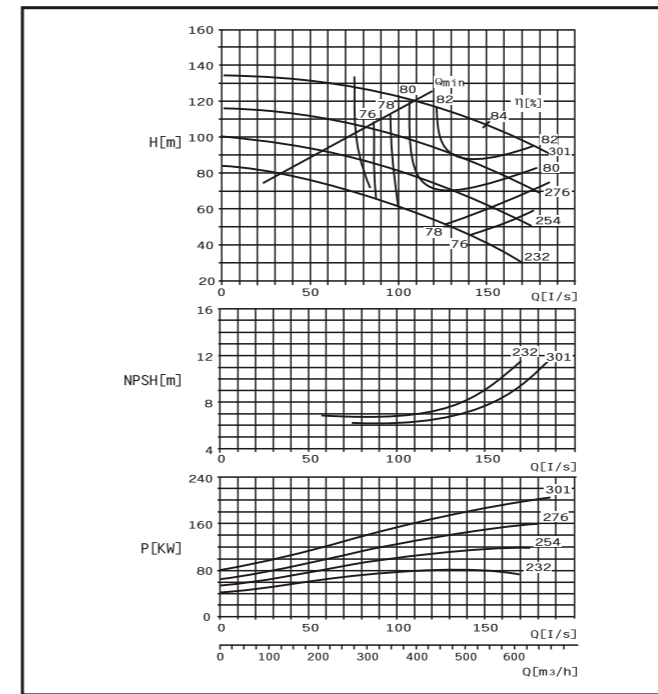

DMC125-290 FG Curve n=2900r/min

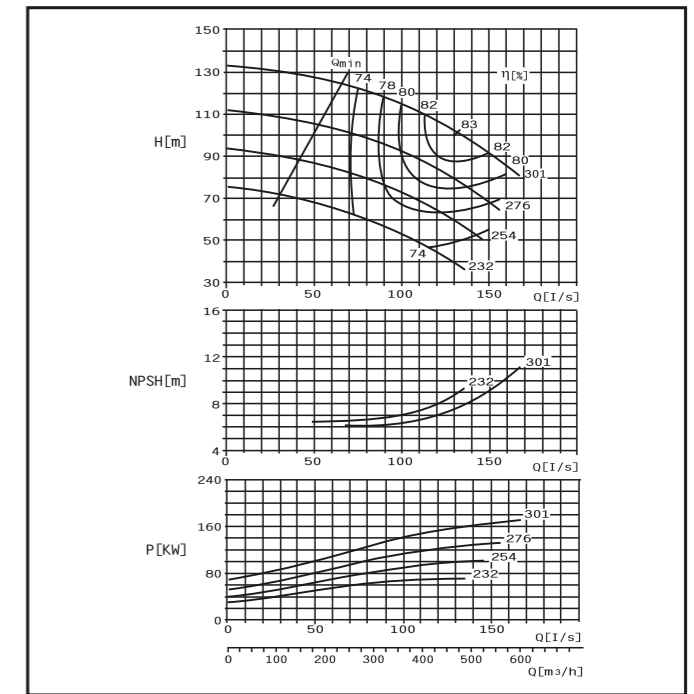

参数表 Standard performance

| 泵型号 Type | 流量 Capacity Q | 扬程 Head m | 转速 Speed r/min | 轴功率 Shaft power kW | 效率 eff η % | 有效汽 蚀余量 NPSHa m | 电机功率 Motor power kW | 叶轮参 考直径 D(mm) |
|------------------|---------------------|-----------------|----------------------|-----------------------------|------------------|--------------------------|------------------------------|---------------------|
| DMC 125-230EG | 426 | 118.4 | 68 | 93.8 | 84.2 | 9.9 | 110 | 245 |
| | 541 | 150.3 | 60 | 101.8 | 85.5 | 10.1 | 90 | 228 |
| | 639 | 177.6 | 48 | 101.9 | 82 | 10.1 | 90 | 228 |
| | 392 | 108.8 | 60 | 78.1 | 82 | 8.2 | 75 | 210 |
| | 490 | 136.1 | 52 | 82.1 | 84 | 8.4 | 75 | 210 |
| | 585 | 163.2 | 43.5 | 84.4 | 82.5 | 8.5 | 75 | 210 |
| DMC 125-230FG | 363 | 100.8 | 60 | 63.4 | 78 | 10.3 | 75 | 210 |
| | 454 | 126 | 43.5 | 65.1 | 82 | 8.2 | 75 | 210 |
| | 544 | 151.2 | 35 | 66.6 | 78 | 7.8 | 75 | 210 |
| | 340 | 94.4 | 40 | 49.4 | 75 | 7.5 | 55 | 193 |
| | 425 | 118 | 34 | 50.8 | 77 | 7.7 | 55 | 193 |
| | 489 | 135.7 | 30 | 52.5 | 76 | 7.6 | 55 | 193 |
| DMC 125-290EG | 377 | 104.8 | 68 | 84.2 | 83 | 12.1 | 110 | 245 |
| | 472 | 181 | 60.5 | 92 | 84.5 | 12.1 | 110 | 245 |
| | 566 | 157.2 | 55 | 101.5 | 83.6 | 12.1 | 110 | 245 |
| | 348 | 96.9 | 60 | 70.3 | 81 | 11.8 | 90 | 228 |
| | 436 | 121 | 53 | 74.8 | 84 | 8.4 | 90 | 228 |
| | 523 | 145.2 | 44 | 77.2 | 81.2 | 8.1 | 90 | 228 |
| DMC 125-290FG | 328 | 91.2 | 52 | 60.1 | 77.5 | 11.9 | 75 | 210 |
| | 410 | 114 | 45 | 61.3 | 82 | 8.2 | 75 | 210 |
| | 493 | 136.7 | 37 | 63.3 | 78.4 | 7.8 | 75 | 210 |
| | 305 | 84.8 | 42.5 | 47.1 | 75 | 7.5 | 55 | 193 |
| | 382 | 106 | 37 | 49.9 | 77 | 7.7 | 55 | 193 |
| | 458 | 127.2 | 30 | 49.9 | 75 | 7.5 | 55 | 193 |

参数表 Standard performance

| 泵型号 Type | 流量 Capacity Q | 扬程 Head m | 转速 Speed r/min | 轴功率 Shaft power kW | 效率 eff η % | 有效汽 蚀余量 NPSHa m | 电机功率 Motor power kW | 叶轮参 考直径 D(mm) |
|------------------|---------------------|-----------------|----------------------|-----------------------------|------------------|--------------------------|------------------------------|---------------------|
| DMC 125-290EG | 428 | 118.8 | 117 | 166 | 82 | 10.9 | 200 | 301 |
| | 535 | 148.5 | 108 | 187 | 84 | 10.7 | 160 | 276 |
| | 640 | 178.3 | 94 | 197 | 83 | 10.5 | 132 | 254 |
| | 397 | 110.3 | 97 | 131 | 80 | 10.7 | 160 | 276 |
| | 497 | 138 | 88 | 145 | 82 | 10.5 | 132 | 254 |
| | 596 | 165.6 | 79 | 153 | 79.5 | 10.4 | 90 | 232 |
| DMC 125-290FG | 383 | 106.4 | 113 | 145 | 81.6 | 10.9 | 185 | 301 |
| | 480 | 133.3 | 100 | 157 | 83 | 10.5 | 132 | 276 |
| | 575 | 159.6 | 85.5 | 166 | 80.5 | 10.1 | 110 | 254 |
| | 348 | 96.7 | 93.5 | 112 | 79.5 | 10.1 | 110 | 254 |
| | 436 | 121 | 83.5 | 121 | 82 | 10.1 | 110 | 254 |
| | 523 | 145.2 | 70 | 126 | 79 | 10.0 | 75 | 232 |

主要外型尺寸 pump outline size

| 泵型号 type | 法兰尺寸 flange size | | | | | | | | | 泵尺寸 pump size | | | | | 泵重量W.T | | | |
|-------------|-------------------|----|-----|-----|--------------------|-----|----|-----|-----|---------------|-----|-----|-----|-----|------------------|-------|-------|------|
| | 进口法兰 inlet flange | | | | 出口法兰 outlet flange | | | | | a1 | a2 | f | h5≤ | 12 | z ¹) | 净重N.T | 湿重G.T | |
| | DN1 | S1 | K | D | n-φd | DN2 | S2 | K | D | | | | | | | | | n-φd |
| 125-230 | 200 | 30 | 295 | 340 | 12-φ22 | 125 | 26 | 210 | 250 | 8-φ17.5 | 370 | 370 | 515 | 825 | 366 | 420 | 250 | 285 |
| 125-290 | | | | | | | | | | | | | | | | 460 | 275 | 315 |

电机尺寸——Y型电机 Motor size(2极)

| 泵型号 Type | 电机Motor | | b2 | h4 | h6 | h7 | l3 | l4 | l5 | i | q | 电机重量(kg) Motor W · T | 底座参考 重量(kg) Baseplate W · T | 地脚螺栓 anchor bolt |
|----------|---------|-----------------|---------|-----|-----|-----|------|------|------|-----|------|-------------------------|-----------------------------------|---------------------|
| | 型号 Type | 功率Power (kW) | | | | | | | | | | | | |
| 125-290 | 125-230 | 250M | 55 | 450 | 320 | 520 | 845 | 1440 | 620 | 105 | 930 | 403 | 110 | 6— M20×400 |
| | | 280S | 75 | 457 | 345 | 545 | 905 | 1520 | 660 | | 1000 | 544 | 140 | |
| | | 280M | 90 | | | | | 1580 | 690 | | 1050 | 577 | 140 | |
| | | 315S | 110 | 508 | 345 | 545 | 1095 | 120 | 1620 | 710 | 1240 | 980 | 190 | |
| | | 315M | 132 | | | | | | 1670 | 735 | 1310 | 1080 | 190 | |
| | | 315L | 160/200 | | | | | | 1700 | 750 | 1310 | 1220 | 190 | |

DMC80-210 E Curve n=1450r/min

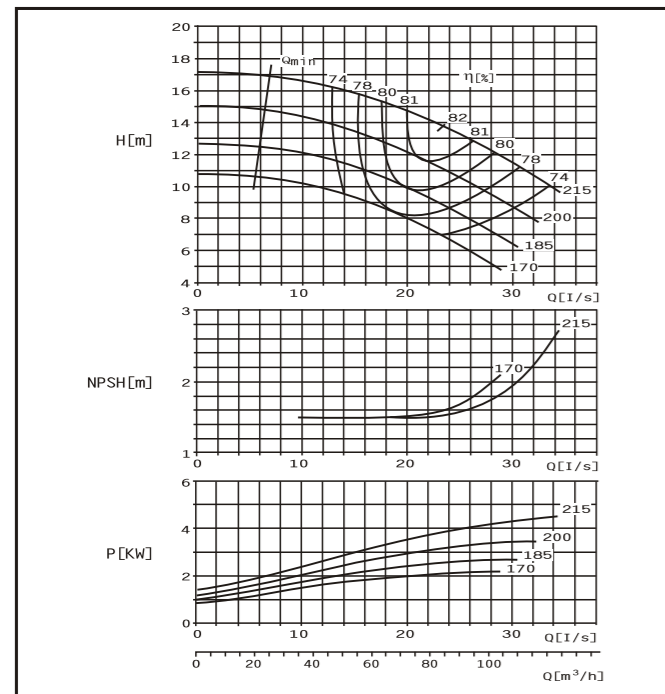

DMC80-210 F Curve n=1450r/min

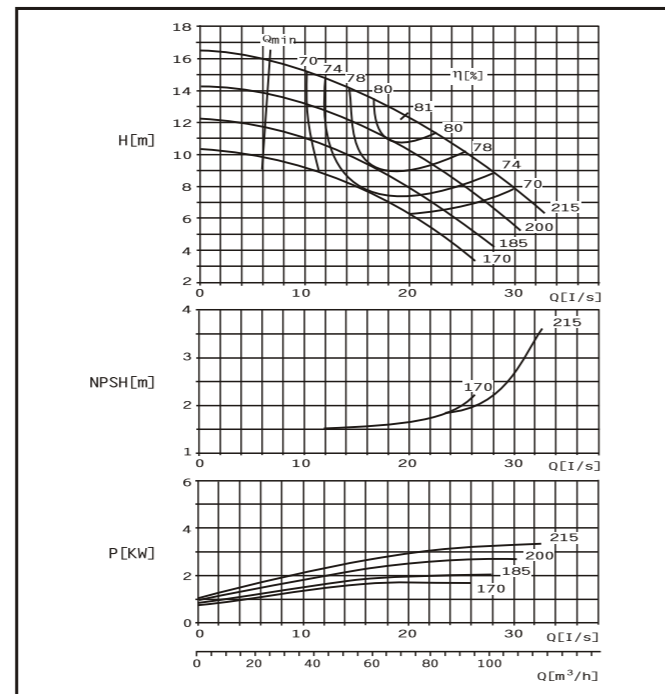

DMC卧式泵安装尺寸图 Installing dimensions of DMC pumps

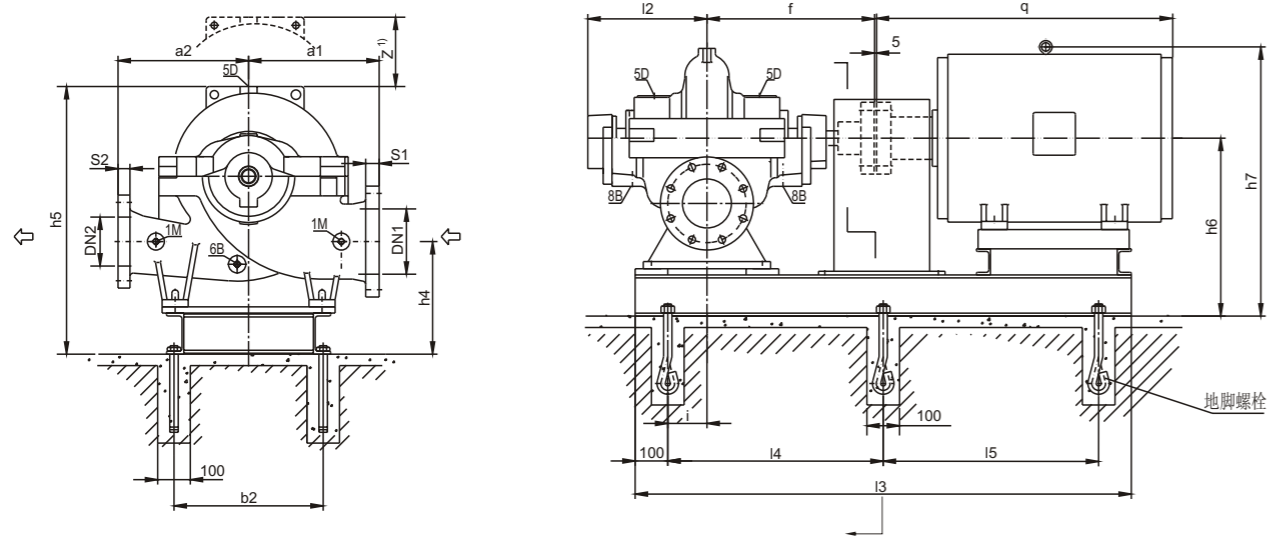

连接尺寸 connection dimensions:

- 1M 压力表Rp1/2 1M pressure gauge Rp1/2
- 6B 排水孔Rp1/2 6B drain plug Rp1/2
- 5D 排气孔Rp1/2 5D air vent Rp1/2
- 8B 漏液排出孔Rp3/4 8B drain plug Rp3/4

Z¹⁾ 拆卸转子所需最小空间尺寸

Z¹⁾ Min. dimensions of disassembling rotor assembly

法兰钻孔示意图

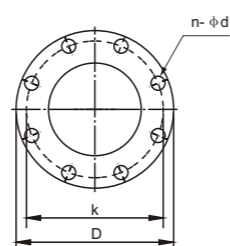

DMC80-270 E Curve n=1450r/min

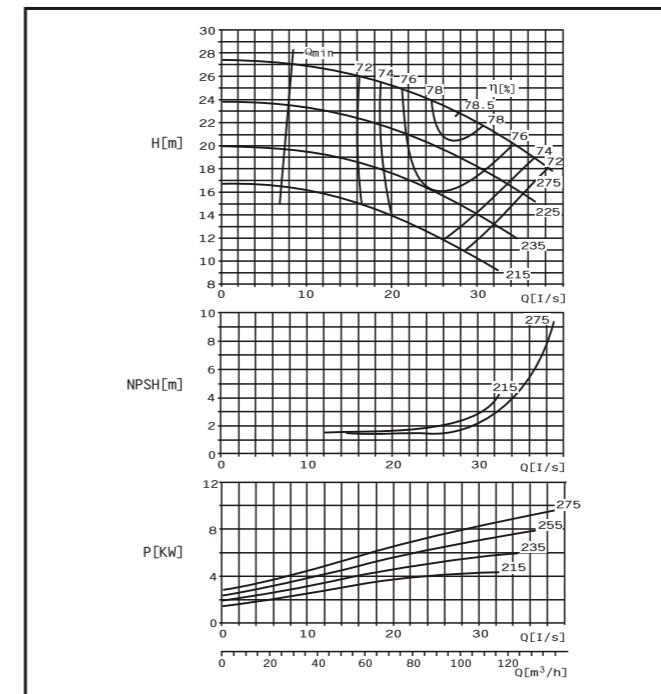

DMC80-270F Curve n=1450 r/min

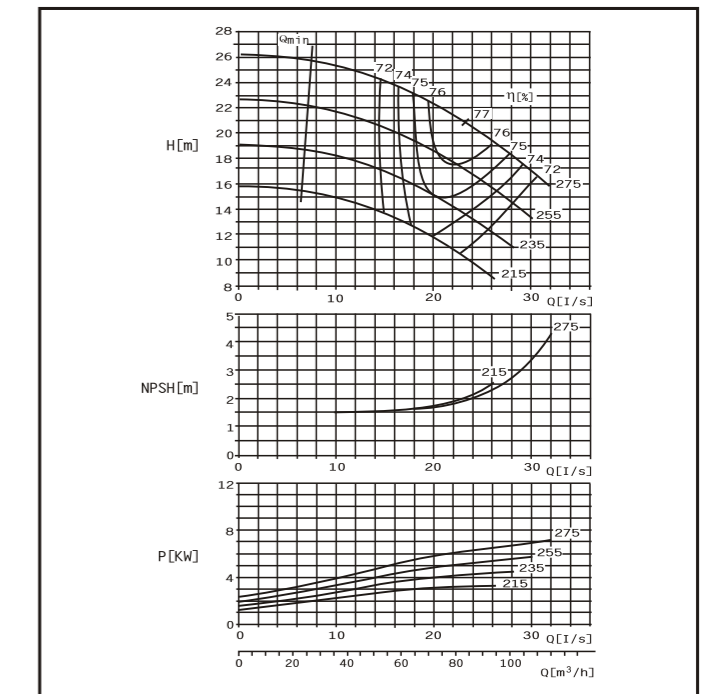

参数表 Standard performance

| 泵型号 Type | 流量 Capacity Q | 扬程 Head m | 转速 Speed r/min | 轴功率 Shaft power kW | 效率 eff η % | 有效汽 蚀余量 NPSHa m | 电机功率 Motor power kW | 叶轮参 考直径 D(mm) |
|----------------|---------------------|-----------------|----------------------|-----------------------------|---------------------|--------------------------|------------------------------|---------------------|
| DMC 80-210E | 66 | 18.3 | 15 | 3.4 | 80.5 | 2.1 | 5.5 | 215 |
| | 83 | 23.1 | 13.8 | 3.8 | 82 | 2.1 | 5.5 | 215 |
| | 100 | 27.8 | 12.2 | 4.2 | 79.5 | 2.1 | 5.5 | 215 |
| | 61 | 16.9 | 13 | 2.7 | 79 | 2.1 | 4.0 | 200 |
| | 76 | 21.1 | 11.8 | 3.0 | 81 | 2.1 | 4.0 | 200 |
| | 90 | 25 | 10.5 | 3.3 | 79.7 | 2.1 | 4.0 | 200 |
| DMC 80-210F | 58 | 16.1 | 11 | 2.2 | 78 | 2.1 | 3.0 | 185 |
| | 72 | 20 | 9.8 | 2.4 | 80.5 | 2.1 | 3.0 | 185 |
| | 87 | 24.2 | 8.7 | 2.6 | 78 | 2.1 | 3.0 | 185 |
| | 55 | 15.3 | 9.1 | 1.8 | 76 | 2.1 | 3.0 | 170 |
| | 69 | 19.2 | 8.2 | 2.0 | 78 | 2.1 | 3.0 | 170 |
| | 83 | 23.1 | 7 | 2.1 | 75 | 2.1 | 3.0 | 170 |
| DMC 80-270E | 52 | 14.5 | 14.2 | 2.6 | 78 | 2.2 | 4.0 | 215 |
| | 55 | 18.1 | 12.8 | 2.8 | 81 | 2.2 | 4.0 | 215 |
| | 58 | 21.7 | 10.0 | 3.1 | 80.2 | 2.2 | 4.0 | 215 |
| | 61 | 14.4 | 12 | 2.1 | 78 | 2.1 | 4.0 | 200 |
| | 64 | 17.8 | 11.8 | 2.6 | 78 | 2.1 | 4.0 | 200 |
| | 77 | 21.4 | 11.7 | 3.1 | 78 | 2.1 | 4.0 | 200 |
| DMC 80-270F | 50 | 13.9 | 10 | 1.8 | 76 | 2.1 | 3.0 | 185 |
| | 61 | 17 | 9 | 1.9 | 78 | 2.1 | 3.0 | 185 |
| | 73 | 20.3 | 7.8 | 2.0 | 76.2 | 2.1 | 3.0 | 185 |
| | 47 | 13.1 | 8.7 | 1.5 | 70 | 2.1 | 2.2 | 170 |
| | 58 | 16.1 | 7.6 | 1.6 | 74 | 2.1 | 2.2 | 170 |
| | 70 | 19.4 | 6.5 | 1.8 | 71 | 2.1 | 2.2 | 170 |

参数表 Standard performance

| 泵型号 Type | 流量 Capacity Q | 扬程 Head m | 转速 Speed r/min | 轴功率 Shaft power kW | 效率 eff η % | 有效汽 蚀余量 NPSHa m | 电机功率 Motor power kW | 叶轮参 考直径 D(mm) |
|----------------|---------------------|-----------------|----------------------|-----------------------------|---------------------|--------------------------|------------------------------|---------------------|
| DMC 80-270E | 83 | 23.1 | 24 | 7.0 | 77.5 | 2.8 | 11 | 275 |
| | 104 | 28.9 | 22.5 | 8.8 | 75 | 2.8 | 11 | 275 |
| | 125 | 34.7 | 19.5 | 10.5 | 75 | 2.8 | 11 | 275 |
| | 80 | 22.2 | 21.3 | 6.1 | 75 | 2.7 | 11 | 255 |
| | 99 | 27.8 | 19 | 6.6 | 78 | 2.7 | 11 | 255 |
| | 120 | 33.3 | 17 | 7.4 | 74.5 | 2.7 | 11 | 255 |
| DMC 80-270F | 72 | 20 | 17.5 | 4.6 | 74.5 | 2.5 | 7.5 | 235 |
| | 90 | 25 | 16 | 5.2 | 76 | 2.5 | 7.5 | 235 |
| | 108 | 30 | 13.7 | 5.4 | 74 | 2.5 | 7.5 | 235 |
| | 67 | 18.6 | 13.8 | 3.4 | 74 | 2.5 | 5.5 | 215 |
| | 84 | 23.3 | 13 | 4.0 | 75 | 2.5 | 5.5 | 215 |
| | 100 | 27.8 | 11.5 | 4.3 | 73.2 | 2.5 | 5.5 | 215 |
| DMC 80-270E | 68 | 18.9 | 23.1 | 5.7 | 75.8 | 2.4 | 7.5 | 275 |
| | 85 | 23.8 | 20.7 | 6.2 | 77 | 2.4 | 7.5 | 275 |
| | 102 | 28.3 | 18.2 | 6.7 | 75.4 | 2.4 | 7.5 | 275 |
| | 61 | 16.9 | 20 | 4.5 | 74.5 | 2.2 | 7.5 | 255 |
| | 67 | 21.4 | 18.1 | 5.0 | 76 | 2.2 | 7.5 | 255 |
| | 92 | 25.5 | 16 | 5.3 | 75 | 2.2 | 7.5 | 255 |
| DMC 80-270F | 58 | 16.1 | 16.5 | 3.5 | 73 | 2.1 | 5.5 | 235 |
| | 72 | 20 | 15 | 3.9 | 75 | 2.1 | 5.5 | 235 |
| | 86 | 23.9 | 13.2 | 4.2 | 74 | 2.1 | 5.5 | 235 |
| | 53 | 14.7 | 13.8 | 2.7 | 72 | 2.1 | 4.0 | 215 |
| | 67 | 18.6 | 12.5 | 3.1 | 74 | 2.1 | 4.0 | 215 |
| | 80 | 22.2 | 10.8 | 3.2 | 73 | 2.1 | 4.0 | 215 |

主要外型尺寸 pump outline size

| 泵型号 type | 法兰尺寸 flange size | | | | | | | | | 泵尺寸 pump size | | | | | 泵重量W.T | | | |
|-------------|-------------------|----|-----|-----|--------------------|-----|----|-----|-----|---------------|-----|-----|-----|-----|-----------------|-------|-------|-----|
| | 进口法兰 inlet flange | | | | 出口法兰 outlet flange | | | | | a1 | a2 | f | h5≤ | 12 | z ¹⁾ | 净重N.T | 湿重G.T | |
| 80-210 | DN1 | S1 | K | D | n-φd | DN2 | S2 | K | D | n-φd | 300 | 300 | 385 | 660 | 300 | 340 | 185 | 195 |
| 80-270 | 125 | 26 | 210 | 250 | 8-φ17.5 | 80 | 24 | 160 | 200 | 8-φ17.5 | 300 | 300 | 385 | 660 | 300 | 380 | 195 | 210 |

电机尺寸——Y型电机 Motor size(4极)

| 泵型号 Type | 电机 Motor | | b2 | h4 | h6 | h7 | l3 | l4 | l5 | i | q | 电机重量(kg) Motor W · T | 底座参考 重量(kg) Baseplate W · T | 地脚螺栓 anchor bolt |
|----------|----------|---------------|---------|-----|-----|-----|-----|------|-----|----|-----|-------------------------|-----------------------------------|---------------------|
| | 型号 Type | 功率 Power (kW) | | | | | | | | | | | | |
| 80-270 | 80-210 | 100L | 2.2/3.0 | 340 | 295 | 435 | 580 | 880 | 340 | 70 | 380 | 39 | 80 | 6— M16×350 |
| | | 112M | 4.0 | | | | 588 | 890 | 345 | | 400 | 45 | | |
| | | 132S | 5.5 | | | | 618 | 930 | 365 | | 475 | 72 | | |
| | | 132M | 7.5 | | | | 618 | 970 | 385 | | 515 | 84 | | |
| | | 160M | 11 | | | | 660 | 1050 | 425 | | 605 | 130 | | |

DMC80-370 E Curve n=1450r/min

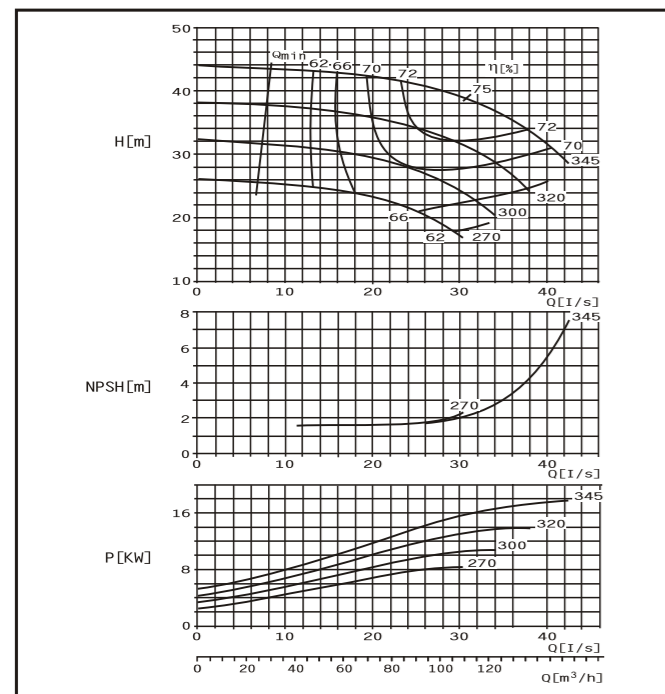

DMC80-370 F Curve n=1450r/min

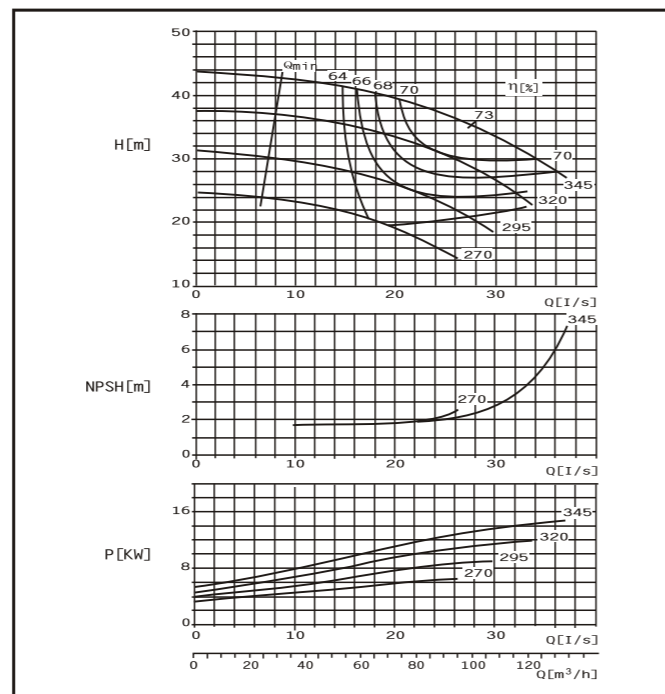

DMC卧式泵安装尺寸图 Installing dimensions of DMC pumps

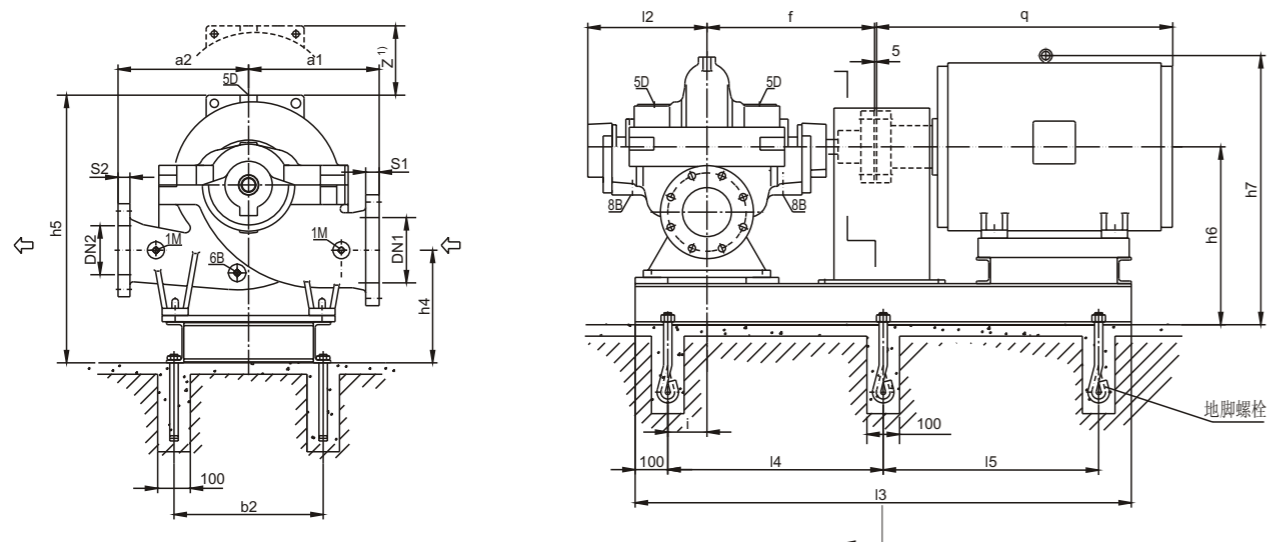

连接尺寸 connection dimensions:

- 1M 压力表Rp1/2 1M pressure gauge Rp1/2
- 6B 排水孔Rp1/2 6B drain plug Rp1/2
- 5D 排气孔Rp1/2 5D air vent Rp1/2
- 8B 漏液排出孔Rp3/4 8B drain plug Rp3/4

Z¹⁾ 拆卸转子所需最小空间尺寸

Z¹⁾ Min. dimensions of disassembling rotor assembly

法兰钻孔示意图

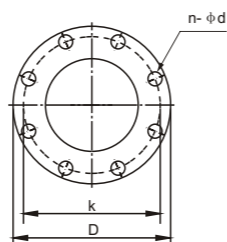

DMC100-250 E Curve n=1450r/min

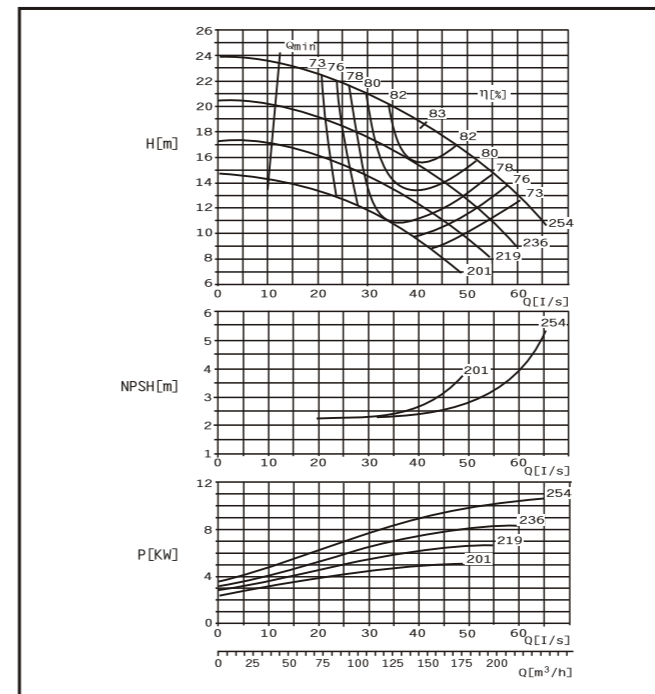

DMC100-250 F Curve n= 1450r/min

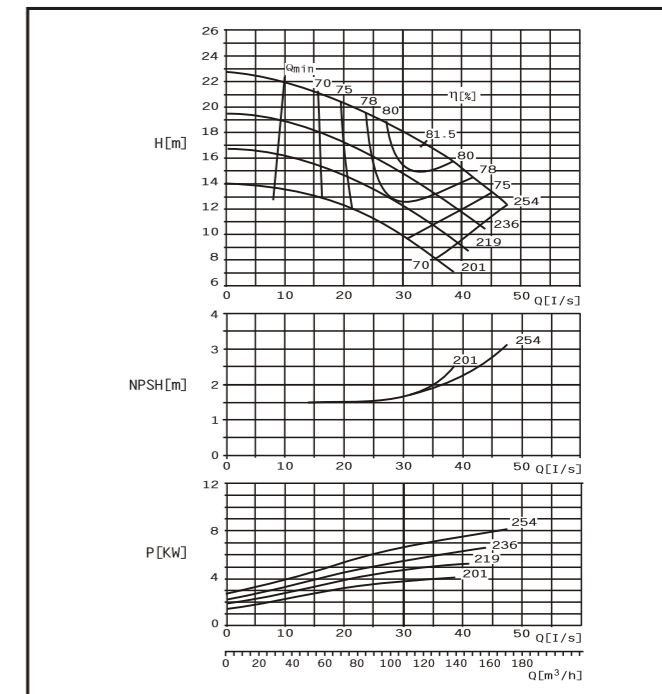

参数表 Standard performance

| 泵型号 Type | 流量 Capacity Q | 扬程 Head m | 转速 Speed r/min | 轴功率 Shaft power kW | 效率 eff η % | 有效汽 蚀余量 NPSHa m | 电机功率 Motor power kW | 叶轮参 考直径 D(mm) |
|----------------|---------------------|-----------------|----------------------|-----------------------------|------------------|--------------------------|------------------------------|---------------------|
| DMC 80-370E | 90 | 25 | 41 | 13.8 | 73 | 2.8 | 18.5 | 345 |
| | 113 | 31.4 | 38.8 | 16.2 | 75 | | | |
| | 136 | 37.8 | 33.5 | 17.3 | 71.8 | | | |
| | 80 | 22.2 | 35.0 | 10.6 | 71 | | 15 | 320 |
| | 99 | 27.5 | 33 | 12.1 | 72.2 | | | |
| | 120 | 33.3 | 29.1 | 13.3 | 71 | | | |
| DMC 80-370F | 70 | 19.4 | 29.3 | 8.2 | 38.4 | | 11 | 300 |
| | 88 | 24.4 | 27.5 | 9.4 | 70 | | | |
| | 106 | 29.4 | 24.7 | 10.2 | 68.3 | | | |
| | 65 | 18.1 | 23.8 | 6.4 | 66 | | 11 | 270 |
| | 81 | 22.5 | 22.5 | 7.4 | 67.5 | | | |
| | 98 | 27.2 | 20 | 8.0 | 65.5 | | | |

参数表 Standard performance

| 泵型号 Type | 流量 Capacity Q | 扬程 Head m | 转速 Speed r/min | 轴功率 Shaft power kW | 效率 eff η % | 有效汽 蚀余量 NPSHa m | 电机功率 Motor power kW | 叶轮参 考直径 D(mm) |
|-----------------|---------------------|-----------------|----------------------|-----------------------------|------------------|--------------------------|------------------------------|---------------------|
| DMC 100-250E | 115 | 31.9 | 21.2 | 8.2 | 80.7 | 2.9 | 11 | 254 |
| | 144 | 40 | 18.8 | 8.9 | 83 | | | |
| | 173 | 48.1 | 17.5 | 10 | 81.7 | | | |
| | 112 | 31 | 17.5 | 6.7 | 79 | | 11 | 236 |
| | 140 | 38.8 | 15.8 | 7.4 | 81 | | | |
| | 167 | 46.5 | 13.2 | 7.7 | 77 | | | |
| DMC 100-250F | 100 | 27.8 | 14.5 | 5.1 | 77.8 | 2.9 | 7.5 | 219 |
| | 126 | 35 | 13.5 | 5.9 | 79 | | | |
| | 150 | 41.7 | 11.9 | 6.3 | 77.6 | | | |
| | 97 | 26.8 | 12.2 | 4.2 | 75.5 | | 7.5 | 201 |
| | 120 | 33.8 | 11.2 | 4.7 | 77.5 | | | |
| | 145 | 40.2 | 9.5 | 5.0 | 75.5 | | | |

主要外型尺寸 pump outline size

| 泵型号 type | 法兰尺寸 flange size | | | | | | 泵尺寸 pump size | | | | | | 泵重量W.T | | | | | |
|-------------|-------------------|----|-----|--------------------|-------|-----|---------------|-----|-----|---------|-----|-----------------|--------|-------|-----|-----|-----|-----|
| | 进口法兰 inlet flange | | | 出口法兰 outlet flange | | | a1 | a2 | f | h5≤ | 12 | z ¹⁾ | 净重N.T | 湿重G.T | | | | |
| 80-370 | DN1 | S1 | K | D | n-φd | DN2 | S2 | K | D | n-φd | 330 | 330 | 385 | 660 | 300 | 450 | 205 | 225 |
| 100-250 | 150 | 28 | 240 | 285 | 8-φ22 | 100 | 24 | 180 | 220 | 8-φ17.5 | 330 | 330 | 385 | 760 | 300 | 390 | 210 | 230 |

电机尺寸——Y型电机 Motor size(4极)

| 泵型号 Type | 电机 Motor | | b2 | h4 | h6 | h7 | l3 | l4 | l5 | i | q | 电机重量(kg) Motor W • T | 底座参考 重量(kg) Baseplate W • T | 地脚螺栓 anchor bolt |
|----------|----------|------------------|-----|-----|-----|-----|-----|-----|----|-----|----|-------------------------|-----------------------------------|---------------------|
| | 型号 Type | 功率 Power (kW) | | | | | | | | | | | | |
| 80-370 | 132M | 7.5 | 340 | 295 | 435 | 618 | 970 | 385 | 70 | 515 | 84 | 80 | 6- M16×350 | |
| | 160M | 11 | | | | | | | | | | | | |
| | 160L | 15 | | | | | | | | | | | | |
| | 180M | 18.5 | | | | | | | | | | | | |
| | 180L | 22 | | | | | | | | | | | | |
| 100-250 | 132S | 5.5 | 400 | 305 | 475 | 658 | 970 | 385 | 70 | 475 | 72 | 80 | 6- M20×400 | |
| | 132M | 7.5 | | | | | | | | | | | | |
| | 160M | 11 | | | | | | | | | | | | |
| | 160L | 15 | | | | | | | | | | | | |
| | 160L | 15 | | | | | | | | | | | | |

DMC100-310 E Curve n=1450r/min

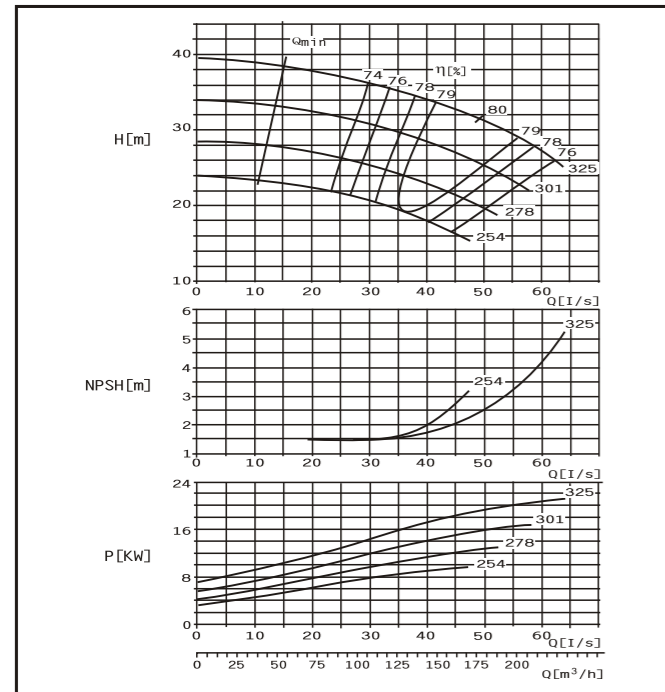

DMC100-310 F Curve n=1450r/min

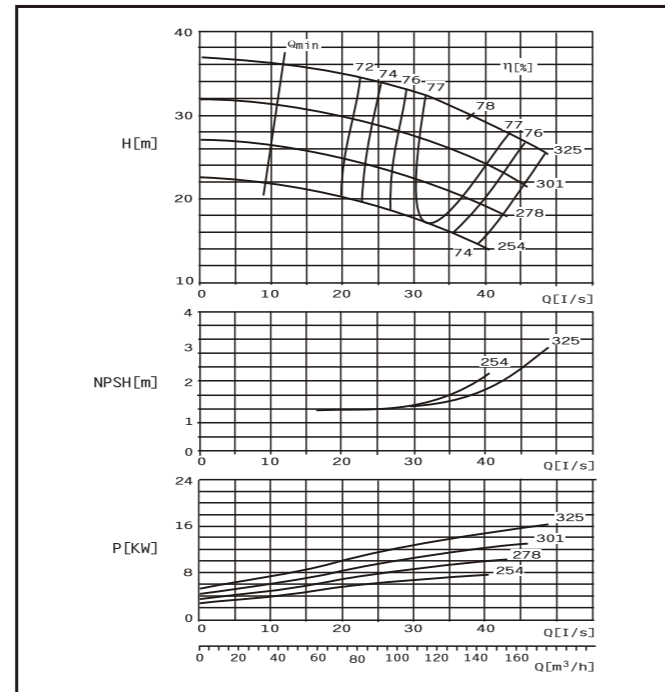

DMC卧式泵安装尺寸图 Installing dimensions of DMC pumps

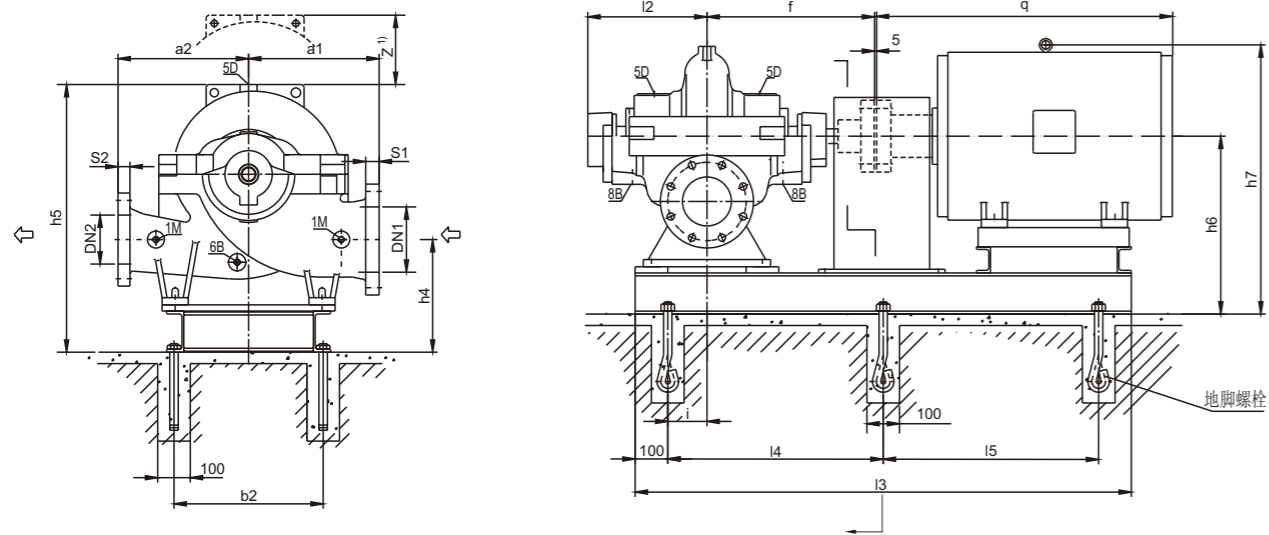

连接尺寸 connection dimensions:

- 1M 压力表Rp1/2 1M pressure gauge Rp1/2
- 6B 排液孔Rp1/2 6B drain plug Rp1/2
- 5D 排气孔Rp1/2 5D air vent Rp1/2
- 8B 漏液排出孔Rp3/4 8B drain plug Rp3/4

Z¹⁾ 拆卸转子所需最小空间尺寸

Z¹⁾ Min. dimensions of disassembling rotor assembly

法兰钻孔示意图

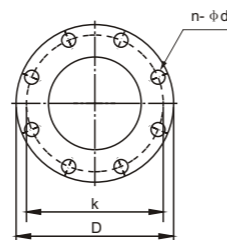

DMC100-375 E Curve n=1450r/min

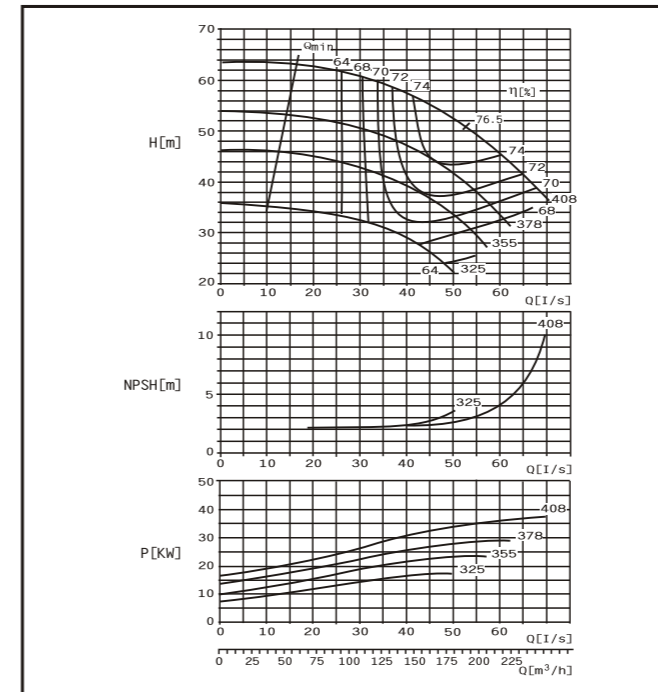

DMC100-375 F Curve n=1450r/min

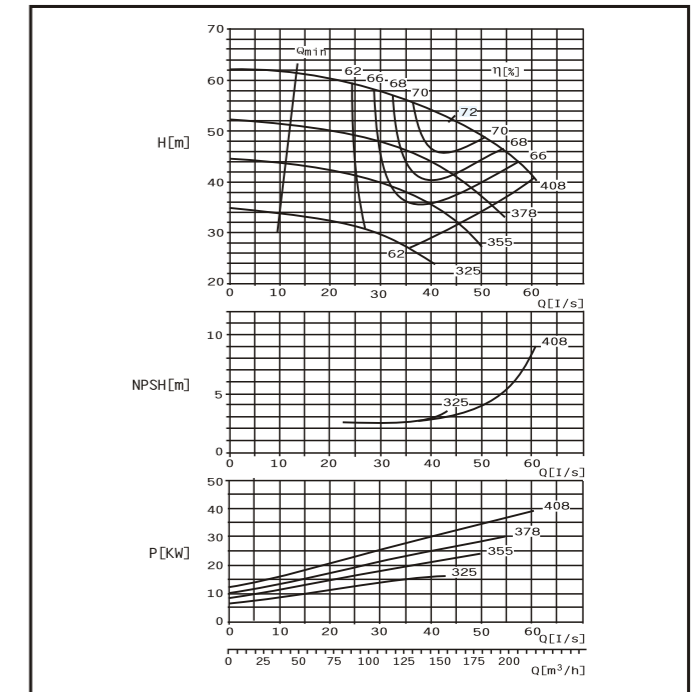

参数表 Standard performance

| 泵型号 Type | 流量 Capacity Q | 扬程 Head m | 转速 Speed r/min | 轴功率 Shaft power kW | 效率 eff η % | 有效汽 蚀余量 NPSHa m | 电机功率 Motor power kW | 叶轮参 考直径 D(mm) |
|-----------------|---------------------|-----------------|----------------------|-----------------------------|------------------|--------------------------|------------------------------|---------------------|
| DMC 100-310E | 148 | 41.1 | 34 | 17.4 | 78.5 | 3.1 | 22 | 325 |
| | 185 | 51.3 | 31 | 19.6 | 80 | 2.7 | 18.5 | 301 |
| | 222 | 61.7 | 26.8 | 21 | 77.5 | 2.5 | 15 | 278 |
| | 133 | 36.8 | 29.3 | 13.4 | 79 | 2.3 | 11 | 254 |
| | 166 | 46.1 | 27 | 15.3 | 79.6 | 2.3 | 11 | 254 |
| | 200 | 55.6 | 24.3 | 17 | 77.4 | 2.3 | 11 | 254 |
| DMC 100-310F | 120 | 33.3 | 24.8 | 10.5 | 78 | 2.5 | 15 | 301 |
| | 151 | 41.9 | 22.5 | 11.7 | 79.3 | 2.5 | 15 | 301 |
| | 180 | 50 | 20 | 12.8 | 77.4 | 2.5 | 15 | 301 |
| | 112 | 31.2 | 20.2 | 7.9 | 77.8 | 2.3 | 11 | 254 |
| | 140 | 38.9 | 18.5 | 9.0 | 79 | 2.3 | 11 | 254 |
| | 162 | 44.9 | 16.2 | 9.2 | 78 | 2.3 | 11 | 254 |

参数表 Standard performance

| 泵型号 Type | 流量 Capacity Q | 扬程 Head m | 转速 Speed r/min | 轴功率 Shaft power kW | 效率 eff η % | 有效汽 蚀余量 NPSHa m | 电机功率 Motor power kW | 叶轮参 考直径 D(mm) |
|-----------------|---------------------|-----------------|----------------------|-----------------------------|------------------|--------------------------|------------------------------|---------------------|
| DMC 100-375E | 148 | 41.1 | 57 | 31.4 | 73 | 3.0 | 45 | 408 |
| | 185 | 51.4 | 51 | 33.5 | 76.5 | 2.7 | 37 | 378 |
| | 220 | 61.1 | 44 | 35.6 | 74 | 2.5 | 30 | 355 |
| | 133 | 36.9 | 47.3 | 24.5 | 71 | 2.5 | 30 | 355 |
| | 167 | 46.4 | 46 | 28.3 | 74 | 2.5 | 30 | 355 |
| | 200 | 55.6 | 38 | 29.2 | 72.3 | 2.5 | 30 | 355 |
| DMC 100-375F | 124 | 34.4 | 41 | 20.3 | 67.5 | 3.6 | 37 | 408 |
| | 155 | 43.1 | 38 | 22.6 | 71 | 3.3 | 30 | 378 |
| | 186 | 51.7 | 31 | 23.1 | 68 | 3.0 | 30 | 355 |
| | 108 | 30 | 32.5 | 14.4 | 66.3 | 2.7 | 18.5 | 325 |
| | 135 | 37.5 | 30.3 | 14.5 | 69 | 2.7 | 18.5 | 325 |
| | 162 | 45 | 25.3 | 16.3 | 66.5 | 2.7 | 18.5 | 325 |

主要外型尺寸 pump outline size

| 泵型号 type | 法兰尺寸 flange size | | | | | | | | | | 泵尺寸 pump size | | | | | 泵重量W.T | | |
|-------------|-------------------|----|-----|-----|-------|--------------------|----|-----|-----|---------|---------------|-----|-----|-----|-----|-----------------|-------|-------|
| | 进口法兰 inlet flange | | | | | 出口法兰 outlet flange | | | | | a1 | a2 | f | h5≤ | 12 | z ¹⁾ | 净重N.T | 湿重G.T |
| | DN1 | S1 | K | D | n-φd | DN2 | S2 | K | D | n-φd | | | | | | | | |
| 100-310 | 150 | 28 | 240 | 285 | 8-φ22 | 100 | 24 | 180 | 220 | 8-φ17.5 | 330 | 330 | 385 | 760 | 300 | 450 | 225 | 250 |
| 100-375 | | | | | | | | | | | 370 | 370 | | | | 520 | 245 | 275 |

电机尺寸——Y型电机 Motor size (4极)

| 泵型号 Type | 电机Motor | | b2 | h4 | h6 | h7 | l3 | l4 | l5 | i | q | 电机重量(kg) Motor W · T | 底座参考 重量(kg) Baseplate W · T | 地脚螺栓 anchor bolt |
|-------------|------------|---------------------|-----|-----|-----|-----|------|-----|----|---|------|-------------------------|-----------------------------------|---------------------|
| | 型号 Type | 功率 Power (kW) | | | | | | | | | | | | |
| 100-310 | 160M | 11 | 400 | 305 | 475 | 700 | 1060 | 430 | 70 | | 605 | 130 | 100 | 6- M20×400 |
| | 160L | 15 | | | | | | | | | 650 | 145 | | |
| | 180M | 18.5 | | | | | | | | | 670 | 180 | | |
| | 180L | 22 | | | | | | | | | 710 | 200 | | |
| | 200L | 30 | | | | | | | | | 775 | 270 | | |
| | 225S | 37 | | | | | | | | | 820 | 284 | | |
| 100-375 | 225M | 45 | 780 | | | 750 | 1190 | 495 | | | 845 | 320 | 190 | |
| | | | | | | | | | | | 1220 | 510 | | |

DMC125-230 E Curve n=1450r/min

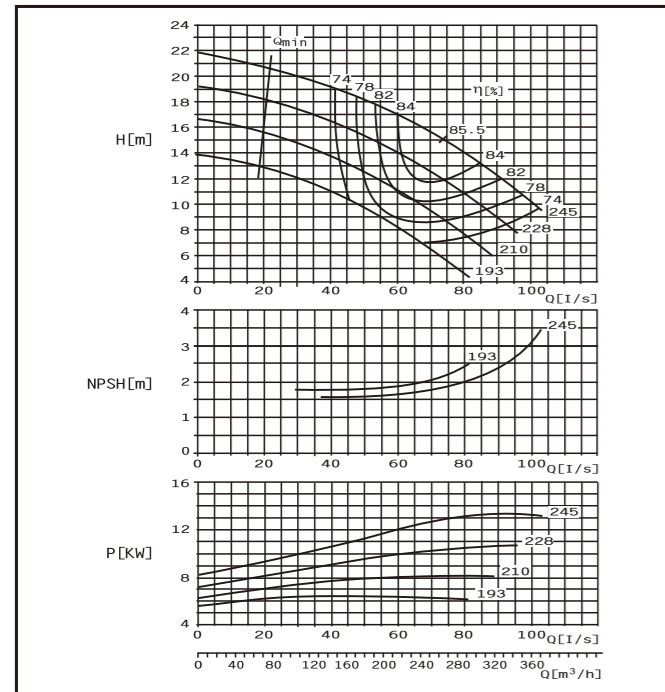

DMC125-230 F Curve n=1450r/min

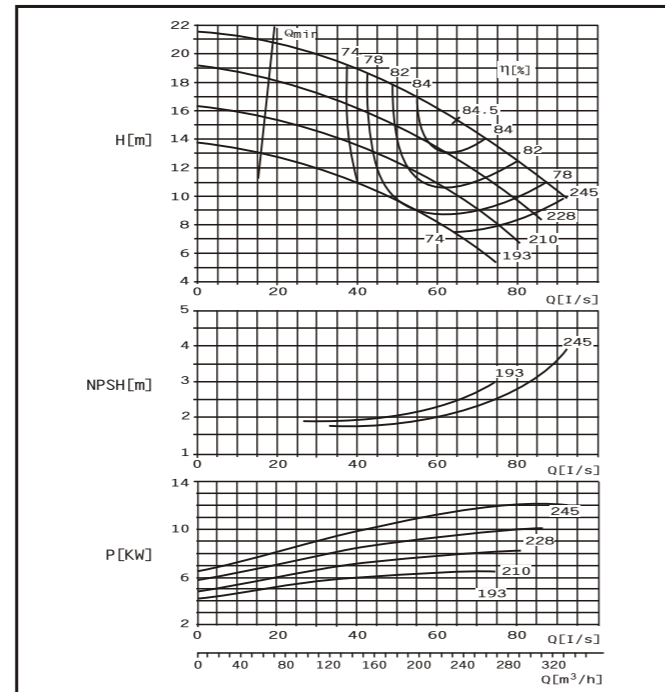

DMC125-290 E Curve n=1450r/min

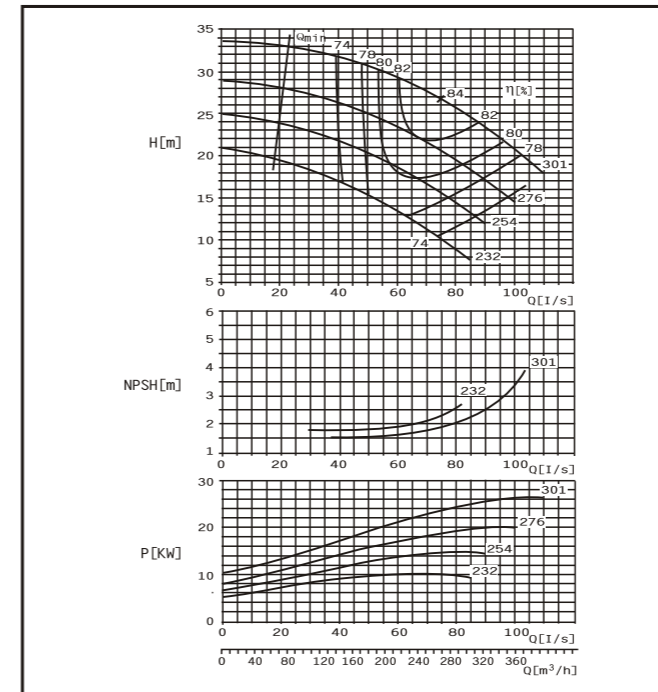

DMC125-290 F Curve n=1450r/min

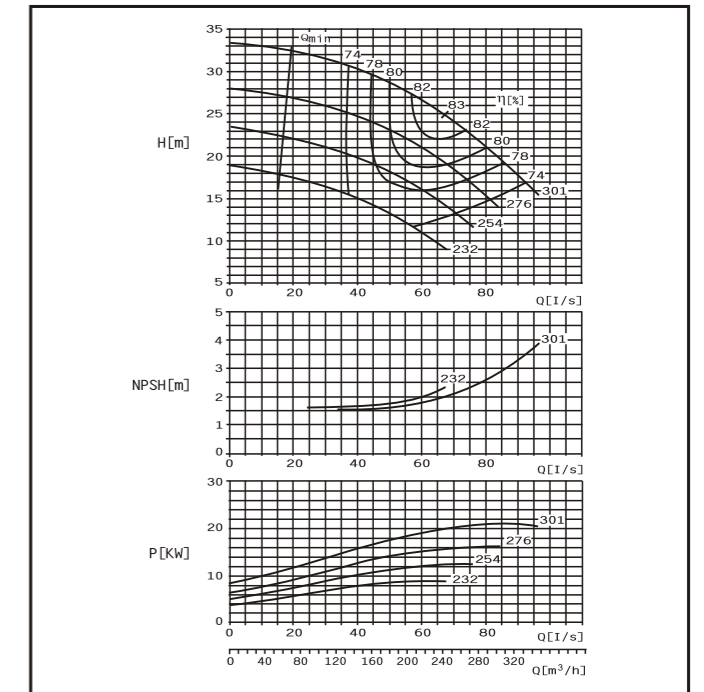

DMC卧式泵安装尺寸图 Installing dimensions of DMC pumps

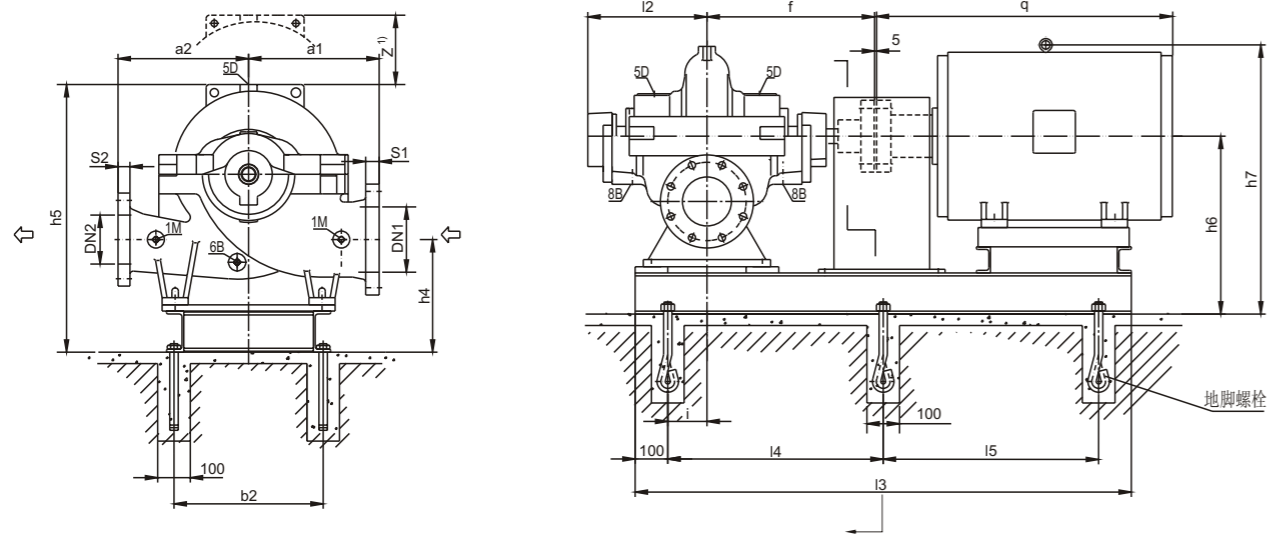

连接尺寸 connection dimensions:

- 1M 压力表Rp1/2 1M pressure gauge Rp1/2
- 6B 排液孔Rp1/2 6B drain plug Rp1/2
- 5D 排气孔Rp1/2 5D air vent Rp1/2
- 8B 漏液排出孔Rp3/4 8B drain plug Rp3/4

Z¹) 拆卸转子所需最小空间尺寸

Z¹) Min. dimensions of disassembling rotor assembly

法兰钻孔示意图

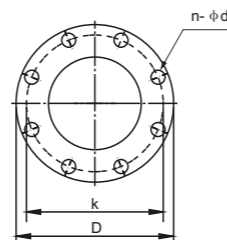

参数表 Standard performance

| 泵型号 Type | 流量 Capacity Q m³/h / l/s | 扬程 Head m | 转速 Speed r/min | 轴功率 Shaft power kW | 效率 eff η % | 有效汽 蚀余量 NPSHa m | 电机功率 Motor power kW | 叶轮参 考直径 D(mm) | | | |
|-----------------|-----------------------------------|-----------------|----------------------|-----------------------------|------------------|--------------------------|------------------------------|---------------------|-----|-----|-----|
| DMC 125-230E | 220 | 81.1 | 17 | 12.1 | 84 | 2.3 | 15 | 245 | | | |
| | 274 | 76.1 | 14.8 | 12.9 | 85.5 | | | | | | |
| | 328 | 91.1 | 12 | 13.1 | 82 | | | | | | |
| | 193 | 53.6 | 15 | 9.7 | 81 | | | | 2.3 | 15 | 228 |
| | 241 | 66.9 | 13.2 | 10.3 | 84.5 | | | | | | |
| | 290 | 80.5 | 10.8 | 10.4 | 82 | | | | | | |
| 184 | 51.1 | 12.6 | 8.0 | 79.4 | 2.2 | 11 | 210 | | | | |
| 230 | 63.9 | 10.6 | 8.1 | 82.5 | | | | | | | |
| 277 | 76.9 | 8.0 | 8.1 | 76 | | | | | | | |
| 167 | 46.4 | 10.3 | 6.4 | 73 | | | | 2.2 | 7.5 | 193 | |
| 209 | 58.1 | 8.7 | 6.4 | 77.5 | | | | | | | |
| 250 | 69.4 | 6.8 | 6.3 | 73 | | | | | | | |
| DMC 125-230F | 190 | 52.8 | 17 | 10.5 | 84.1 | 2.7 | 15 | | | | 245 |
| | 238 | 66.1 | 15.1 | 11.6 | 84.5 | | | | | | |
| | 307 | 85.3 | 11.5 | 12.0 | 80 | | | | | | |
| | 170 | 47.2 | 12 | 8.6 | 81 | | | 2.7 | 11 | 228 | |
| | 212 | 58.9 | 13.5 | 9.3 | 84 | | | | | | |
| | 255 | 70.8 | 11.4 | 9.7 | 82 | | | | | | |
| 164 | 45.6 | 13.0 | 7.5 | 78 | 2.7 | 11 | 210 | | | | |
| 205 | 56.9 | 11.5 | 7.8 | 82 | | | | | | | |
| 246 | 68.4 | 9.2 | 7.9 | 78 | | | | | | | |
| 156 | 43.2 | 10.5 | 5.9 | 75 | | | | 2.7 | 7.5 | 193 | |
| 195 | 54.2 | 9.1 | 6.2 | 78 | | | | | | | |
| 223 | 61.9 | 7.7 | 6.3 | 74 | | | | | | | |

参数表 Standard performance

| 泵型号 Type | 流量 Capacity Q m³/h / l/s | 扬程 Head m | 转速 Speed r/min | 轴功率 Shaft power kW | 效率 eff η % | 有效汽 蚀余量 NPSHa m | 电机功率 Motor power kW | 叶轮参 考直径 D(mm) | | | |
|-----------------|-----------------------------------|-----------------|----------------------|-----------------------------|------------------|--------------------------|------------------------------|---------------------|------|-----|-----|
| DMC 125-290E | 215 | 59.7 | 29.2 | 20.8 | 82.3 | 2.4 | 30 | 301 | | | |
| | 269 | 74.7 | 27 | 23.6 | 84 | | | | | | |
| | 323 | 89.7 | 23.5 | 25.2 | 82 | | | | | | |
| | 195 | 54.2 | 24.4 | 16.1 | 80.3 | | | | 2.4 | 22 | 276 |
| | 243 | 67.5 | 22 | 17.8 | 82 | | | | | | |
| | 292 | 81.1 | 19.6 | 19.5 | 80 | | | | | | |
| 178 | 49.4 | 20 | 12.3 | 79 | 2.3 | 15 | 254 | | | | |
| 223 | 61.9 | 18 | 13.7 | 80 | | | | | | | |
| 268 | 74.4 | 15.5 | 14.4 | 78.3 | | | | | | | |
| 161 | 44.7 | 16.3 | 9.3 | 77 | | | | 2.3 | 15 | 232 | |
| 202 | 56.1 | 14.2 | 10 | 78 | | | | | | | |
| 242 | 67.2 | 11.8 | 10.2 | 76.2 | | | | | | | |
| DMC 125-290F | 193 | 53.6 | 27.5 | 17.8 | 81 | 2.4 | 22 | | | | 301 |
| | 241 | 66.9 | 25 | 19.3 | 83 | | | | | | |
| | 290 | 80.6 | 21.3 | 20.6 | 80 | | | | | | |
| | 174 | 48.3 | 23.4 | 13.9 | 80 | | | 2.3 | 18.5 | 276 | |
| | 218 | 60.6 | 21 | 15.2 | 82 | | | | | | |
| | 261 | 72.5 | 17.5 | 16 | 78 | | | | | | |
| 157 | 43.6 | 19 | 10.4 | 78 | 2.2 | 15 | 254 | | | | |
| 196 | 54.4 | 17.5 | 11.8 | 79 | | | | | | | |
| 235 | 65.3 | 15 | 12.3 | 78 | | | | | | | |
| 138 | 38.3 | 15.1 | 7.7 | 74.3 | | | | 2.2 | 11 | 232 | |
| 173 | 48.1 | 13.7 | 8.5 | 76 | | | | | | | |
| 207 | 57.5 | 11.3 | 8.6 | 74 | | | | | | | |

主要外型尺寸 pump outline size

| 泵型号 type | 法兰尺寸 flange size | | | | | | | | | | 泵尺寸 pump size | | | | | 泵重量W.T | | |
|-------------|-------------------|----|-----|-----|--------|--------------------|----|-----|-----|---------|---------------|-----|-----|-------|------------------|--------|-------|-----|
| | 进口法兰 inlet flange | | | | | 出口法兰 outlet flange | | | | | a1 | a2 | f | h5≤12 | z ¹) | 净重N.T | 湿重G.T | |
| | DN1 | S1 | K | D | n-φd | DN2 | S2 | K | D | n-φd | | | | | | | | |
| 125-230 | 200 | 30 | 295 | 340 | 12-φ22 | 125 | 26 | 210 | 250 | 8-φ17.5 | 370 | 370 | 515 | 825 | 366 | 420 | 250 | 285 |
| 125-290 | | | | | | | | | | | | | | | | 460 | 275 | 315 |

电机尺寸——Y型电机 Motor size(4极)

| 泵型号 Type | 电机Motor | | b2 | h4 | h6 | h7 | l3 | l4 | l5 | i | q | 电机重量(kg) Motor W · T | 底座参考 重量(kg) Baseplate W · T | 地脚螺栓 anchor bolt | | | | | | | |
|-------------|------------|-----------------|-----|-----|-----|-----|------|-----|-----|---|-----|-------------------------|-----------------------------------|---------------------|--|--|--|--|--|-----|--|
| | 型号 Type | 功率Power (kW) | | | | | | | | | | | | | | | | | | | |
| 125-230 | 132M | 7.5 | 450 | 320 | 520 | 703 | 1100 | 450 | 105 | | 515 | 84 | 80 | 6- M20×400 | | | | | | | |
| | 160M | 11 | | | | 745 | 1190 | 495 | | | 605 | 130 | | | | | | | | | |
| | 160L | 15 | | | | | | | | | 650 | 145 | | | | | | | | | |
| | 180M | 18.5 | | | | | | | | | 670 | 180 | | | | | | | | | |
| | 180L | 22 | | | | | | | | | 710 | 200 | | | | | | | | | |
| | 200L | 30 | | | | | | | | | 775 | 270 | | | | | | | | | |
| | 225S | 37 | | | | | | | | | 820 | 284 | | | | | | | | | |
| | 125-290 | | | | | | | | | | | | | | | | | | | 190 | |

DMC125-365 E Curve n=1450r/min

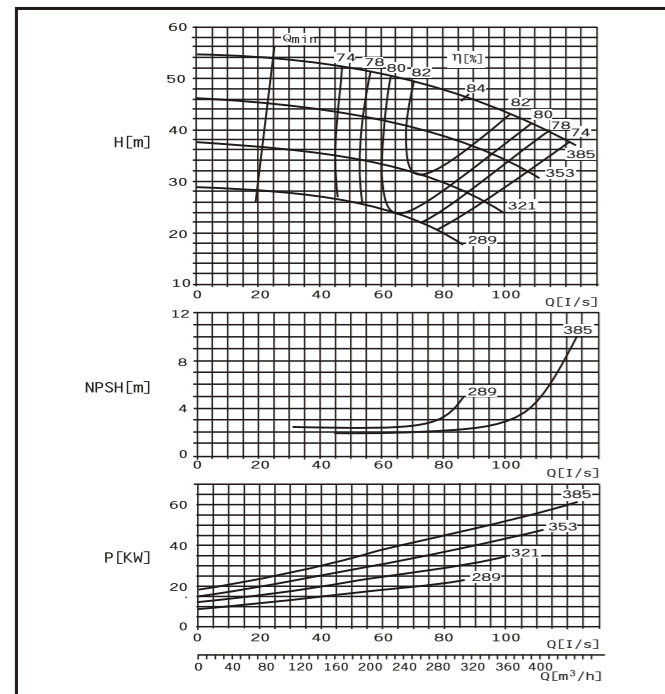

DMC125-365 F Curve n=1450r/min

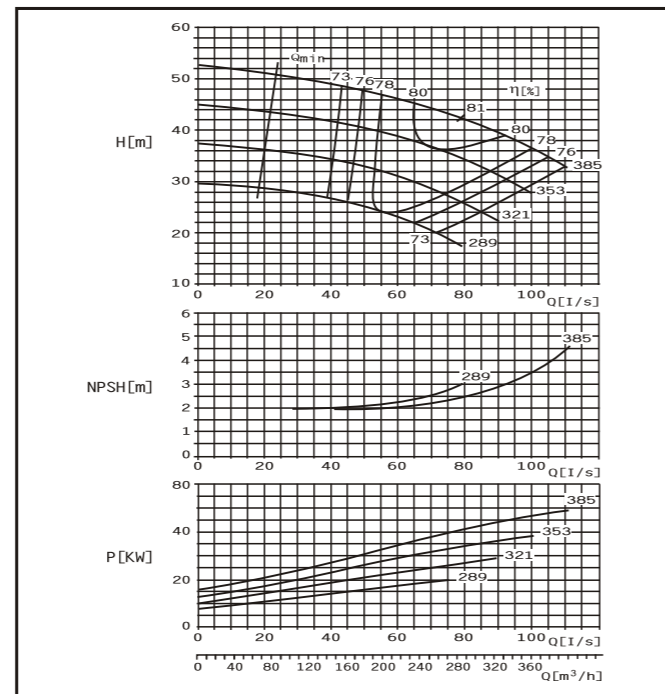

DMC125-500 E Curve n=1450r/min

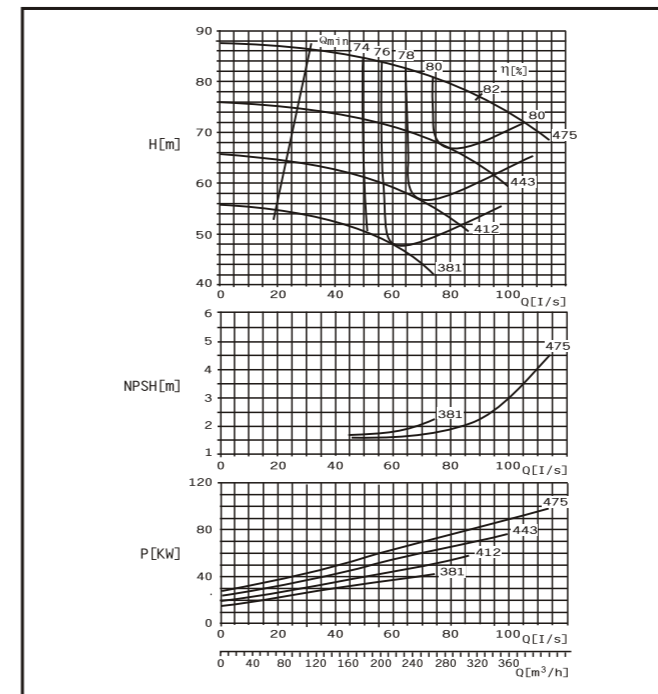

DMC125-500 F Curve n=1450r/min

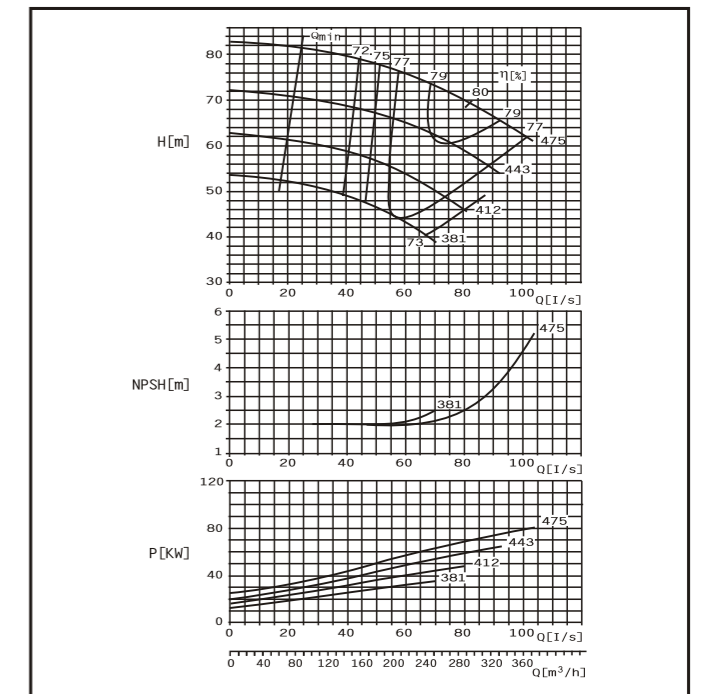

DMC卧式泵安装尺寸图 Installing dimensions of DMC pumps

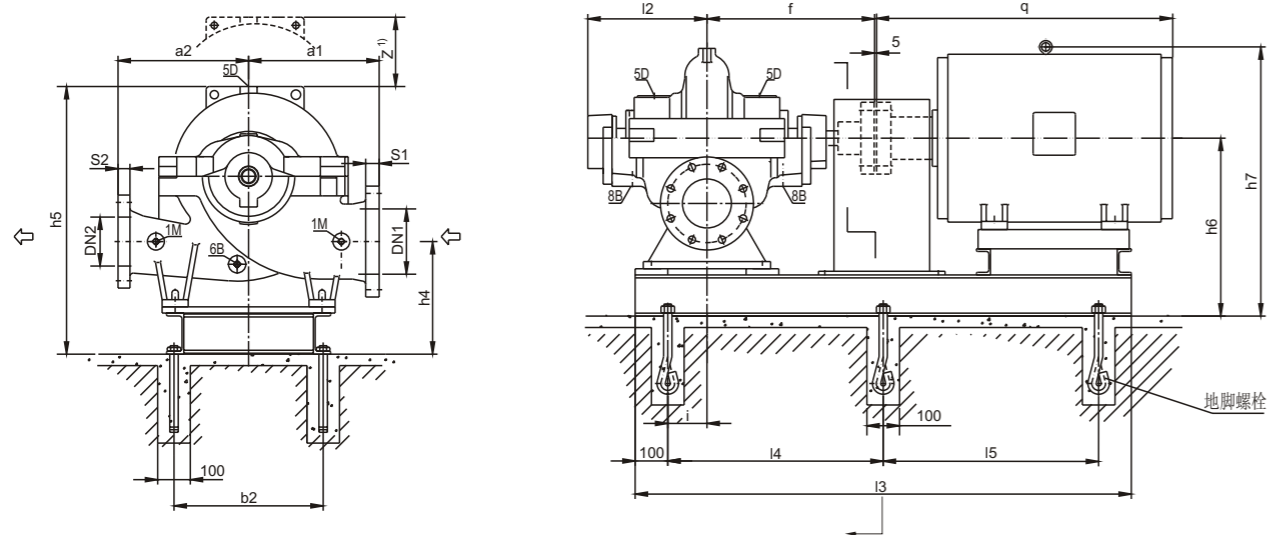

连接尺寸 connection dimensions:

- 1M 压力表Rp1/2 1M pressure gauge Rp1/2
- 6B 排液孔Rp1/2 6B drain plug Rp1/2
- 5D 排气孔Rp1/2 5D air vent Rp1/2
- 8B 漏液排出孔Rp3/4 8B drain plug Rp3/4

Z¹⁾ 拆卸转子所需最小空间尺寸

Z¹⁾ Min. dimensions of disassembling rotor assembly

法兰钻孔示意图

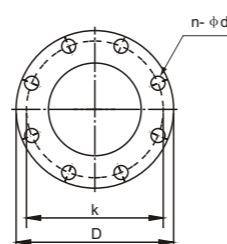

参数表 Standard performance

| 泵型号 Type | 流量 Capacity Q | 扬程 Head m | 转速 Speed r/min | 轴功率 Shaft power kW | 效率 eff η % | 有效汽 蚀余量 NPSHa m | 电机功率 Motor power kW | 叶轮参 考直径 D(mm) |
|-----------------|---------------------|-----------------|----------------------|-----------------------------|---------------------|--------------------------|------------------------------|---------------------|
| DMC 125-365E | 245 | 68.8 | 50 | 41.2 | 82 | 2.6 | 55 | 385 |
| | 310 | 86 | 47 | 47.2 | 84 | | | |
| | 360 | 100 | 44 | 52.3 | 82 | | | |
| | 225 | 62.4 | 41.6 | 31.8 | 80 | 2.8 | 45 | 353 |
| | 281 | 78 | 39 | 36 | 83 | | | |
| | 337 | 93.6 | 35.6 | 40.4 | 81.2 | | | |
| DMC 125-365F | 205 | 56.8 | 33.7 | 24.2 | 76 | 2.9 | 37 | 321 |
| | 256 | 71 | 31.5 | 26.8 | 82 | | | |
| | 307 | 85.2 | 28.2 | 29.8 | 79.5 | | | |
| | 184 | 51.2 | 25.5 | 16.9 | 76 | 3.0 | 22 | 289 |
| | 230 | 64 | 24 | 18.8 | 80 | | | |
| | 278 | 76.8 | 20.9 | 20.2 | 78 | | | |

参数表 Standard performance

| 泵型号 Type | 流量 Capacity Q | 扬程 Head m | 转速 Speed r/min | 轴功率 Shaft power kW | 效率 eff η % | 有效汽 蚀余量 NPSHa m | 电机功率 Motor power kW | 叶轮参 考直径 D(mm) |
|-----------------|---------------------|-----------------|----------------------|-----------------------------|---------------------|--------------------------|------------------------------|---------------------|
| DMC 125-500E | 262 | 72.8 | 82 | 73.7 | 79.5 | 2.8 | 110 | 475 |
| | 328 | 91 | 76 | 82.7 | 82 | | | |
| | 393 | 109.2 | 70 | 96.4 | 77.8 | | | |
| | 233 | 64.8 | 70 | 56.7 | 78.5 | 2.7 | 90 | 443 |
| | 292 | 81 | 65.5 | 67.3 | 80 | | | |
| | 342 | 95 | 62 | 74.8 | 77.2 | | | |
| DMC 125-500F | 205 | 56.8 | 60 | 44.0 | 76 | 2.5 | 75 | 412 |
| | 256 | 71 | 56 | 50.6 | 77 | | | |
| | 307 | 85.2 | 51.5 | 56.5 | 76 | | | |
| | 184 | 51.2 | 50 | 34.2 | 73.5 | 3.2 | 90 | 475 |
| | 230 | 64 | 47 | 38.8 | 76.5 | | | |
| | 252 | 70 | 45 | 40.7 | 76 | | | |

主要外型尺寸 pump outline size

| 泵型号 type | 法兰尺寸 flange size | | | | | | | | | | 泵尺寸 pump size | | | | | 泵重量W.T | | |
|-------------|-------------------|----|-----|-----|--------|--------------------|-----|-----|-----|---------|---------------|-----|-----|-----|-----|-----------------|-------|-------|
| | 进口法兰 inlet flange | | | | | 出口法兰 outlet flange | | | | | a1 | a2 | f | h5≤ | 12 | z ¹⁾ | 净重N.T | 湿重G.T |
| | DN1 | S1 | K | D | n-φd | DN2 | S2 | K | D | n-φd | | | | | | | | |
| 125-365 | 200 | 30 | 295 | 340 | 12-φ22 | 125 | 26 | 210 | 250 | 8-φ17.5 | 370 | 370 | 515 | 825 | 366 | 520 | 300 | 345 |
| 125-500 | | | | | | 450 | 450 | | | | 450 | 450 | | | | 610 | 335 | 390 |

电机尺寸——Y型电机 Motor size(4极)

| 泵型号 Type | 电机Motor | | b2 | h4 | h6 | h7 | l3 | l4 | l5 | i | q | 电机重量(kg) | | 底座参考 重量(kg) | 地脚螺栓 anchor bolt |
|-------------|---------|-----------------|-----|-----|-----|-----|------|-----|-----|-----|-----|----------|-----------------|----------------|---------------------|
| | 型号 Type | 功率Power (kW) | | | | | | | | | | Motor W | Baseplate W · T | | |
| 125-365 | 180L | 22 | 450 | 320 | 520 | 770 | 1280 | 540 | 105 | 710 | 200 | 200 | 110 | 6-M20×400 | |
| | 200L | 30 | | | | | | | | | | | | | 270 |
| | 225S | 37 | | | | | | | | | | | | | 284 |
| | 225M | 45 | | | | | | | | | | | | | 320 |
| | 250M | 55 | | | | | | | | | | | | | 427 |
| | 280S | 75 | | | | | | | | | | | | | 562 |
| 125-500 | 225S | 37 | 560 | 320 | 520 | 825 | 1440 | 620 | 105 | 820 | 284 | 190 | 250 | 6-M20×400 | |
| | 225M | 45 | | | | | | | | | | | | | 320 |
| | 250M | 55 | | | | | | | | | | | | | 427 |
| | 280S | 75 | | | | | | | | | | | | | 562 |
| | 280M | 90 | | | | | | | | | | | | | 667 |
| | 315S | 110 | | | | | | | | | | | | | 1000 |

DMC150-290 E Curve n=1450r/min

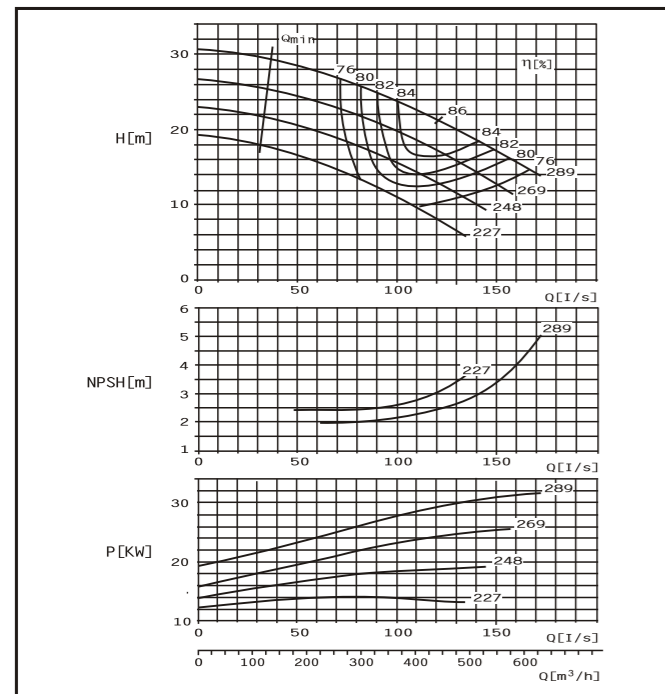

DMC150-290 F Curve n=1450r/min

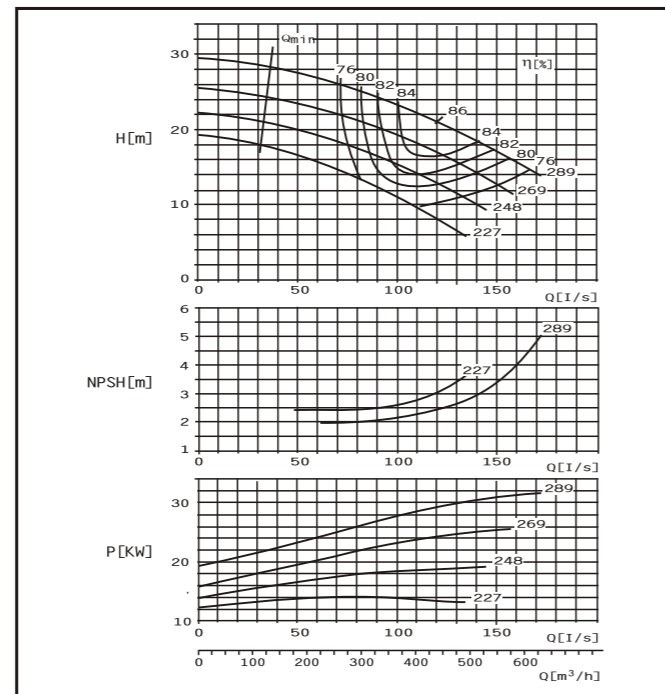

DMC150-360 E Curve n=1450r/min

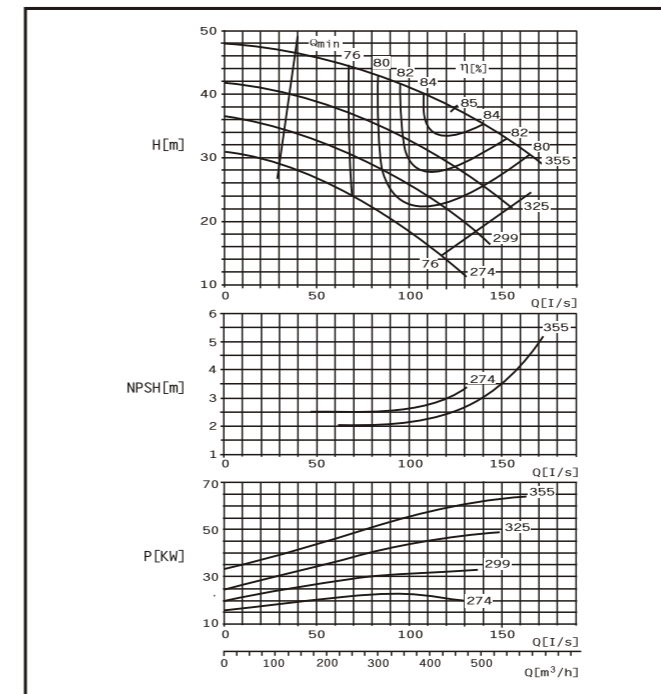

DMC150-360 F Curve n=1450r/min

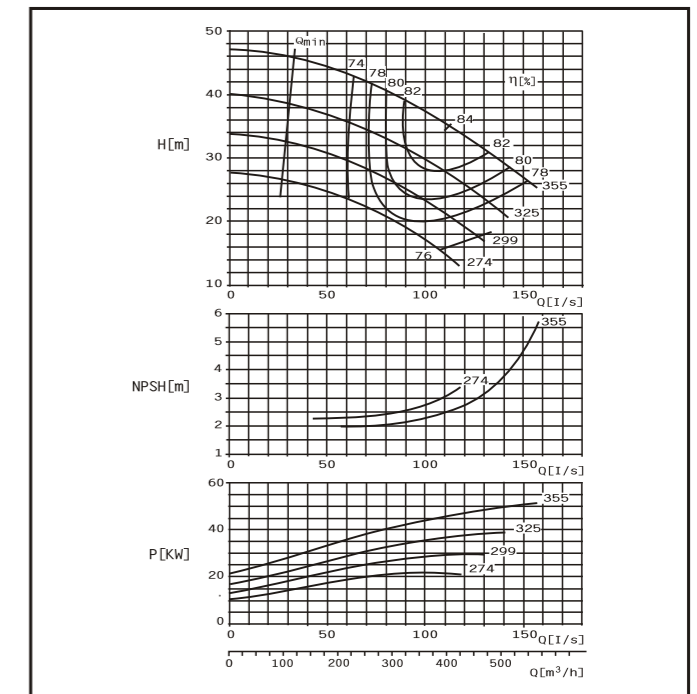

DMC卧式泵安装尺寸图 Installing dimensions of DMC pumps

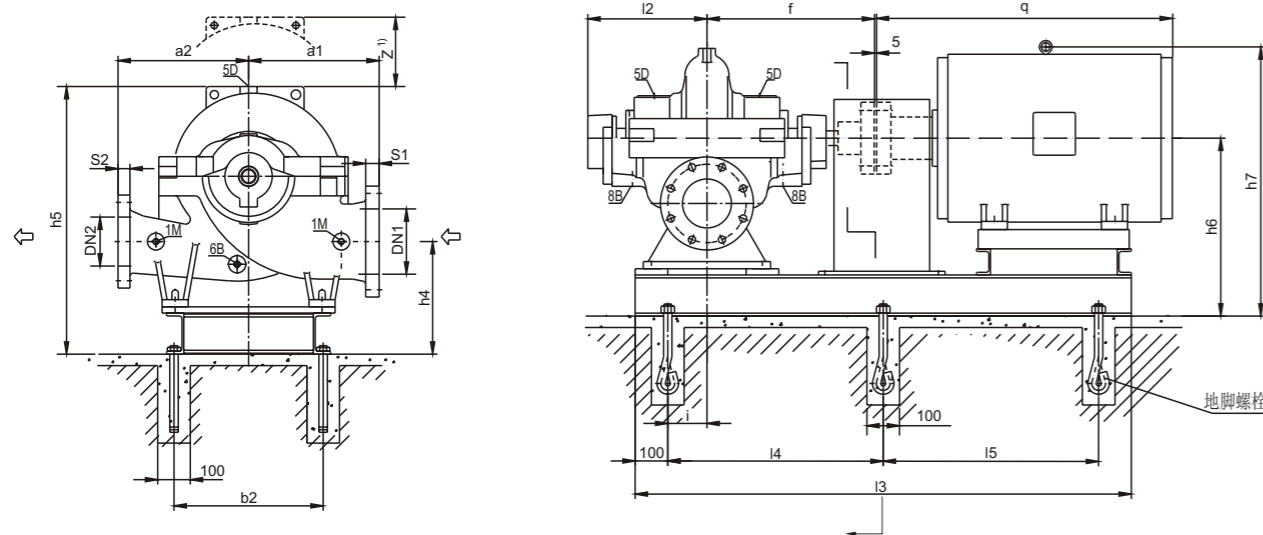

连接尺寸 connection dimensions:

- 1M 压力表Rp1/2 1M pressure gauge Rp1/2
- 6B 排水孔Rp1/2 6B drain plug Rp1/2
- 5D 排气孔Rp1/2 5D air vent Rp1/2
- 8B 漏液排出孔Rp3/4 8B drain plug Rp3/4

Z¹⁾ 拆卸转子所需最小空间尺寸

Z¹⁾ Min. dimensions of disassembling rotor assembly

法兰钻孔示意图

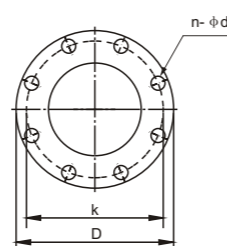

参数表 Standard performance

| 泵型号 Type | 流量 Capacity Q m³/h l/s | 扬程 Head m | 转速 Speed r/min | 轴功率 Shaft power kW | 效率 eff η % | 有效汽 蚀余量 NPSHa m | 电机功率 Motor power kW | 叶轮参 考直径 D(mm) | | | |
|-----------------|------------------------------------|-----------------|----------------------|-----------------------------|---------------------|--------------------------|------------------------------|---------------------|-----|------|-----|
| DMC 150-290E | 354 | 98.3 | 24 | 27.1 | 85.6 | 2.9 | 37 | 289 | | | |
| | 443 | 123 | 21 | 29.1 | 87 | | | | | | |
| | 531 | 147.5 | 17.5 | 30.3 | 83.5 | | | | | | |
| | 323 | 89.7 | 21 | 22.2 | 83 | | | | 2.9 | 30 | 269 |
| | 403 | 112 | 18 | 23 | 86 | | | | | | |
| | 484 | 134.4 | 15 | 24 | 82.3 | | | | | | |
| 302 | 83.9 | 17.5 | 18 | 80 | 2.9 | 22 | 248 | | | | |
| 378 | 105 | 15 | 18.4 | 84 | | | | | | | |
| 454 | 125 | 12.3 | 19.1 | 79.4 | | | | | | | |
| DMC 150-290F | 280 | 77.8 | 13.7 | 13.9 | | | | 75 | 3.0 | 18.5 | 227 |
| | 350 | 97.2 | 11.5 | 14.2 | | | | 77 | | | |
| | 396 | 110 | 10 | 14.2 | | | | 76 | | | |
| | 317 | 88 | 23.4 | 24 | 84.2 | 3.0 | 30 | 289 | | | |
| | 396 | 110 | 20.4 | 25.6 | 86 | | | | | | |
| | 475 | 132 | 16.6 | 25.7 | 83.5 | | | | | | |
| 302 | 84 | 20 | 19.9 | 82.8 | 3.1 | | | | 22 | 269 | |
| 378 | 105 | 17 | 20.6 | 85 | | | | | | | |
| 454 | 125 | 13.7 | 20.7 | 82 | | | | | | | |
| 282 | 78.3 | 17.5 | 16.6 | 80.6 | | 3.1 | 18.5 | 248 | | | |
| 353 | 98 | 14.5 | 16.6 | 84 | | | | | | | |
| 423 | 117.5 | 11.3 | 16.5 | 79 | | | | | | | |
| 265 | 73.6 | 14 | 13.0 | 76.7 | 3.1 | | | | 15 | 227 | |
| 331 | 92 | 11.5 | 13.0 | 80 | | | | | | | |
| 378 | 105 | 9.8 | 13.3 | 76 | | | | | | | |

参数表 Standard performance

| 泵型号 Type | 流量 Capacity Q m³/h l/s | 扬程 Head m | 转速 Speed r/min | 轴功率 Shaft power kW | 效率 eff η % | 有效汽 蚀余量 NPSHa m | 电机功率 Motor power kW | 叶轮参 考直径 D(mm) | | | |
|-----------------|------------------------------------|-----------------|----------------------|-----------------------------|---------------------|--------------------------|------------------------------|---------------------|-----|-----|-----|
| DMC 150-360E | 357 | 99.2 | 41.3 | 48.4 | 83 | 3.0 | 75 | 355 | | | |
| | 446 | 124 | 38 | 54.3 | 85 | | | | | | |
| | 536 | 148.9 | 34.2 | 60.4 | 82.7 | | | | | | |
| | 323 | 89.7 | 34.2 | 36.9 | 81.5 | | | | 3.0 | 45 | 325 |
| | 403 | 112 | 31 | 41 | 83 | | | | | | |
| | 484 | 134.4 | 26.3 | 42.9 | 80.8 | | | | | | |
| 298 | 82.8 | 28.7 | 29.4 | 79 | 3.0 | 37 | 299 | | | | |
| 370 | 102.8 | 25 | 31.2 | 81 | | | | | | | |
| 445 | 123.6 | 21 | 32.3 | 78.8 | | | | | | | |
| 265 | 73.6 | 23.4 | 22.1 | 76.5 | | | | 3.1 | 30 | 274 | |
| 331 | 92 | 20 | 23.1 | 78 | | | | | | | |
| 389 | 110.6 | 16.7 | 23.3 | 77.6 | | | | | | | |
| DMC 150-360F | 325 | 90.3 | 39.2 | 42.3 | 82.1 | 3.0 | 55 | | | | 355 |
| | 407 | 113 | 35 | 46.2 | 84 | | | | | | |
| | 488 | 135.6 | 30 | 49.3 | 81 | | | | | | |
| | 294 | 81.7 | 33 | 32.8 | 80.5 | | | 3.0 | 45 | 325 | |
| | 367 | 102 | 29.5 | 36 | 82 | | | | | | |
| | 440 | 122.2 | 25 | 37.5 | 80 | | | | | | |
| 267 | 74.2 | 27.5 | 25.4 | 78.8 | 3.0 | 37 | 299 | | | | |
| 334 | 92.8 | 25 | 28.5 | 80 | | | | | | | |
| 400 | 111.1 | 21.3 | 29.8 | 78 | | | | | | | |
| 233 | 64.7 | 22.8 | 19.5 | 75.7 | | | | 3.0 | 30 | 274 | |
| 292 | 81.1 | 20.5 | 22 | 79 | | | | | | | |
| 350 | 97.2 | 17.5 | 22 | 76 | | | | | | | |

主要外型尺寸 pump outline size

| 泵型号 type | 法兰尺寸 flange size | | | | | | | | 泵尺寸 pump size | | | | | 泵重量W.T | | | | |
|-------------|-------------------|----|-----|-----|--------------------|-----|----|-----|---------------|-------|-----|-----|-----|-----------------|-------|-------|-----|------|
| | 进口法兰 inlet flange | | | | 出口法兰 outlet flange | | | | a1 | a2 | f | h5≤ | 12 | z ¹⁾ | 净重N.T | 湿重G.T | | |
| | DN1 | S1 | K | D | n-φd | DN2 | S2 | K | | | | | | | | | D | n-φd |
| 150-290 | 200 | 30 | 295 | 340 | 12-φ22 | 150 | 26 | 240 | 280 | 8-φ22 | 400 | 400 | 515 | 1050 | 366 | 490 | 350 | 400 |
| 150-360 | | | | | | | | | | | | | | | | 530 | 360 | 420 |

电机尺寸——Y型电机 Motor size(4极)

| 泵型号 Type | 电机 Motor | | b2 | h4 | h6 | h7 | l3 | l4 | l5 | i | q | 电机重量(kg) Motor W • T | 底座参考 重量(kg) Baseplate W • T | 地脚螺栓 anchor bolt |
|----------|----------|------------------|-----|-----|-----|-----|------|-----|-----|------|---|-------------------------|-----------------------------------|---------------------|
| | 型号 Type | 功率 Power (kW) | | | | | | | | | | | | |
| 150-290 | 160L | 15 | 450 | 320 | 520 | 745 | 1240 | 520 | 105 | | | 650 | 145 | 6— M20×400 |
| | 180M | 18.5 | | | | | | | | | | 670 | 180 | |
| | 180L | 22 | | | | | | | | | | 710 | 200 | |
| | 200L | 30 | | | | | | | | | | 775 | 270 | |
| | 225S | 37 | | | | | | | | | | 820 | 284 | |
| | 225M | 45 | | | | | | | | | | 845 | 320 | |
| | 250M | 55 | | | | | | | | | | 845 | 427 | |
| | 280S | 75 | | | | | | | | | | 905 | 562 | |
| 150-360 | | | 457 | 345 | 545 | 905 | 1520 | 660 | 120 | 1000 | | 562 | 250 | |
| | | | | | | | | | | | | | | |

DMC150-460 E Curve n=1450r/min

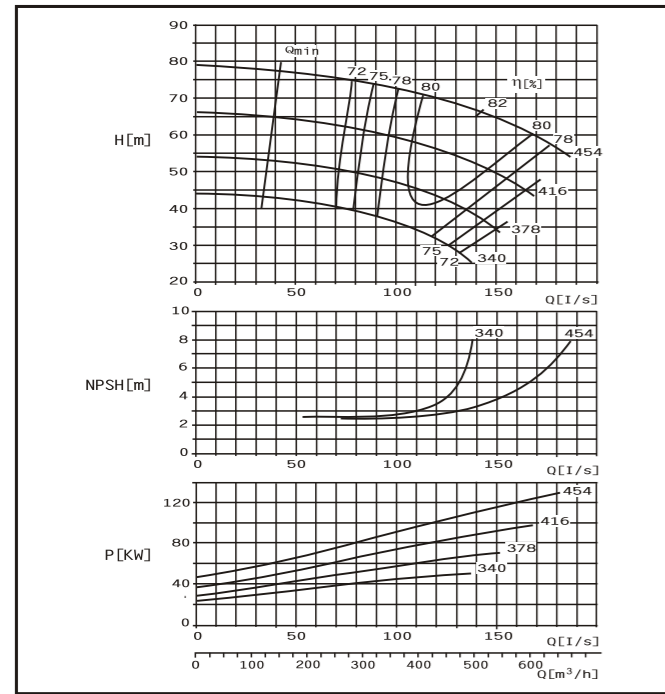

DMC150-460 F Curve n=1450r/min

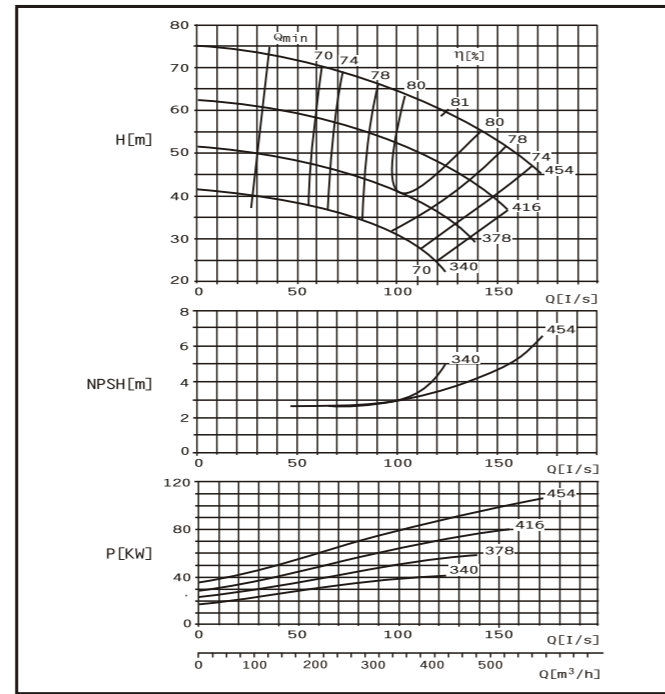

DMC150-605 E Curve n=1450r/min

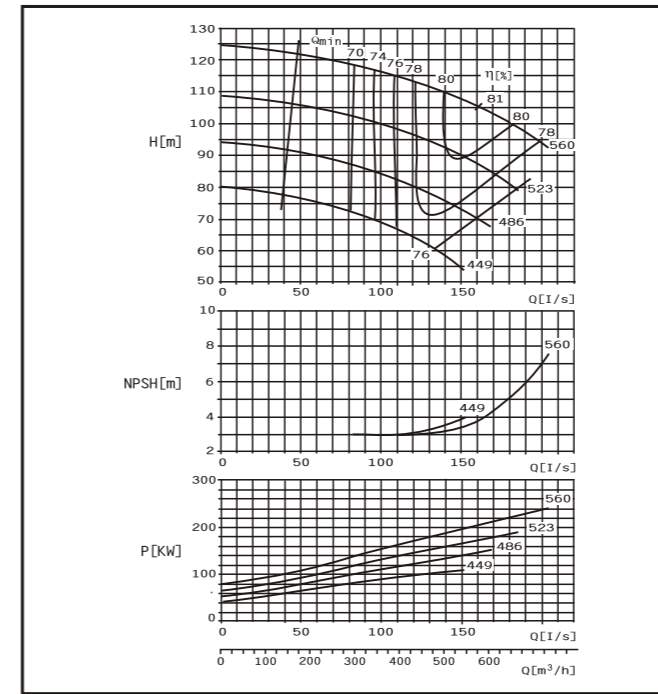

DMC150-605 F Curve n=1450r/min

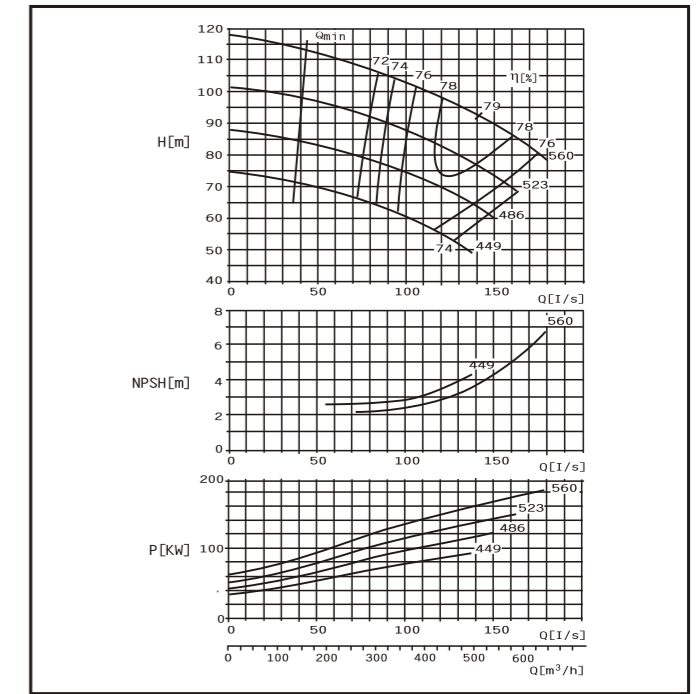

DMC卧式泵安装尺寸图 Installing dimensions of DMC pumps

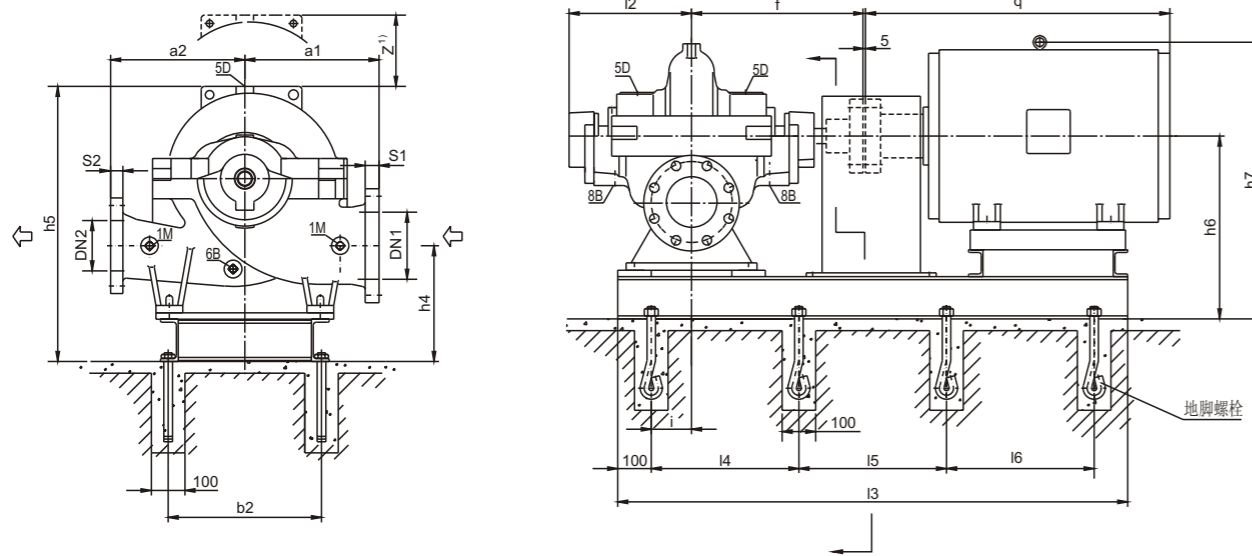

连接尺寸 connection dimensions:

- 1M 压力表 Rp1/2 1M pressure gauge Rp1/2
- 6B 排液孔 Rp1/2 6B drain plug Rp1/2
- 5D 排气孔 Rp1/2 5D air vent Rp1/2
- 8B 漏液排出孔 Rp3/4 8B drain plug Rp3/4

Z¹ 拆卸转子所需最小空间尺寸

Z¹ Min.dimensions of disassembling rotor assembly

法兰钻孔示意图

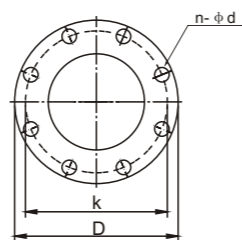

参数表 Standard performance

| 泵型号 Type | 流量 Capacity Q m³/h l/s | 扬程 Head m | 转速 Speed r/min | 轴功率 Shaft power kW | 效率 eff η % | 有效汽 蚀余量 NPSHa m | 电机功率 Motor power kW | 叶轮参 考直径 D(mm) |
|-----------------|------------------------------------|-----------------|----------------------|-----------------------------|---------------------|--------------------------|------------------------------|---------------------|
| DMC 150-460E | 412 | 114.4 | 71 | 99.4 | 80.2 | 3.9 | 132 | 454 |
| | 515 | 143.1 | 66 | 112.8 | 82 | 80 | 110 | 416 |
| | 618 | 171.6 | 60 | 126.2 | 78 | 75 | 75 | 378 |
| | 377 | 104.7 | 58 | 75.2 | 79.3 | 3.8 | 110 | 416 |
| | 472 | 131.1 | 54.5 | 86.4 | 81 | 80 | 75 | 378 |
| | 566 | 157.2 | 48 | 94.9 | 78 | 3.7 | 55 | 340 |
| | 317 | 88 | 38 | 57 | 78.5 | 77 | 45 | 340 |
| | 396 | 110 | 35 | 64 | 80 | 78.5 | 45 | 340 |
| | 475 | 132 | 28.2 | 69.7 | 75 | 72 | 45 | 340 |
| | 350 | 97.2 | 65 | 78.3 | 79.5 | 3.9 | 110 | 454 |
| DMC 150-460F | 440 | 122.2 | 60 | 88.6 | 81 | 80 | 110 | 416 |
| | 527 | 146.4 | 53.5 | 97.6 | 78.7 | 3.7 | 90 | 416 |
| | 323 | 89.7 | 54 | 60.3 | 78.7 | 3.7 | 90 | 416 |
| | 403 | 112 | 50 | 68.2 | 80.5 | 3.7 | 75 | 378 |
| | 484 | 134.4 | 44.5 | 75.2 | 78 | 3.4 | 75 | 378 |
| | 300 | 83.3 | 44.4 | 46.5 | 78 | 74 | 45 | 340 |
| | 375 | 104 | 40 | 51 | 80 | 74 | 45 | 340 |
| | 450 | 125 | 34.5 | 57.1 | 74 | 74 | 45 | 340 |
| | 280 | 72.2 | 35.5 | 33.5 | 74.8 | 3.2 | 45 | 340 |
| | 324 | 90 | 33 | 37.3 | 74 | 3.2 | 45 | 340 |

参数表 Standard performance

| 泵型号 Type | 流量 Capacity Q m³/h l/s | 扬程 Head m | 转速 Speed r/min | 轴功率 Shaft power kW | 效率 eff η % | 有效汽 蚀余量 NPSHa m | 电机功率 Motor power kW | 叶轮参 考直径 D(mm) |
|-----------------|------------------------------------|-----------------|----------------------|-----------------------------|---------------------|--------------------------|------------------------------|---------------------|
| DMC 150-605E | 467 | 129.7 | 112 | 182.6 | 78 | 4.2 | 250 | 560 |
| | 583 | 161.9 | 105 | 206 | 81 | 78 | 200 | 523 |
| | 700 | 194.4 | 95.5 | 233.4 | 79 | 76.3 | 160 | 486 |
| | 440 | 122.2 | 96 | 151.1 | 76.3 | 78 | 160 | 486 |
| | 550 | 152.7 | 85.5 | 168 | 79 | 76.3 | 110 | 449 |
| | 648 | 180 | 81 | 187.5 | 76.3 | 78 | 110 | 449 |
| | 412 | 114.4 | 82 | 120 | 76.6 | 78 | 110 | 449 |
| | 515 | 143 | 75 | 134.8 | 78 | 74 | 110 | 449 |
| | 605 | 168 | 68 | 151.4 | 74 | 74 | 110 | 449 |
| | 378 | 105 | 67.5 | 92.3 | 75.2 | 74 | 110 | 449 |
| DMC 150-605F | 430 | 119.4 | 98 | 149.2 | 76.8 | 4.7 | 200 | 560 |
| | 536 | 148.9 | 90 | 166.4 | 79 | 76 | 160 | 523 |
| | 617 | 171.4 | 82 | 181.5 | 76 | 74 | 160 | 523 |
| | 392 | 108.9 | 85 | 118.9 | 76.3 | 78 | 160 | 523 |
| | 490 | 136.1 | 78 | 133.3 | 78 | 74 | 110 | 449 |
| | 576 | 160 | 70 | 148.1 | 74.2 | 74 | 110 | 449 |
| | 357 | 99.2 | 75 | 96.2 | 75.9 | 77 | 110 | 449 |
| | 446 | 124 | 68.5 | 108.2 | 77 | 74 | 110 | 449 |
| | 535 | 148.8 | 60 | 118.4 | 74 | 74 | 110 | 449 |
| | 323 | 89.7 | 62.5 | 73.4 | 74.9 | 76 | 110 | 449 |

主要外型尺寸 pump outline size

| 泵型号 type | 法兰尺寸 flange size | | | | | | | | | | 泵尺寸 pump size | | | | | 泵重量W.T | | |
|-------------|-------------------|----|-----|-----|--------|--------------------|----|-----|-----|-------|---------------|-----|-----|------|-----|----------------|-------|-------|
| | 进口法兰 inlet flange | | | | | 出口法兰 outlet flange | | | | | a1 | a2 | f | h5≤ | 12 | z ¹ | 净重N.T | 湿重G.T |
| 150-460 | DN1 | S1 | K | D | n-φd | DN2 | S2 | K | D | n-φd | 450 | 450 | 590 | 1050 | 399 | 610 | 436 | 511 |
| 150-605 | 200 | 36 | 310 | 365 | 12-φ25 | 150 | 32 | 250 | 305 | 8-φ25 | 600 | 500 | | | | 740 | 646 | 736 |

电机尺寸——Y型电机 Motor size

| 泵型号 Type | 电机Motor | | b2 | h4 | h6 | h7 | l3 | l4 | l5 | l6 | i | q | 电机重量 Motor W · T (kg) | 底座参考 重量(kg) Baseplate W · T | 地脚螺栓 anchor bolt |
|----------|----------|-----------------|-----|-----|-----|------|------|------|----|-----|---|------|-----------------------------|-----------------------------------|---------------------|
| | 型号 Type | 功率Power (kW) | | | | | | | | | | | | | |
| 150-460 | 225M | 45 | 560 | 320 | 520 | 825 | 1500 | 650 | - | 150 | | 845 | 320 | 250 | 6-M20×400 |
| | 250M | 55 | | | | 845 | 1560 | 680 | | | | 930 | 427 | | |
| | 280S | 75 | | | | 1000 | 1630 | 715 | | | | 1000 | 562 | | |
| | 280M | 90 | | | | 1050 | 1680 | 740 | | | | 1050 | 667 | | |
| | 315S | 110 | | | | 1270 | 1750 | 775 | | | | 1270 | 1000 | | |
| | 315M | 132 | | | | 1340 | 1800 | 800 | | | | 1340 | 1100 | | |
| 150-605 | 315S | 110 | 700 | 380 | 680 | 1230 | 1750 | 775 | - | 150 | | 1270 | 1000 | 410 | |
| | 315M | 132 | | | | 1340 | 1800 | 800 | | | | 1340 | 1100 | | |
| | 315L | 160/200 | | | | 1830 | 815 | 1830 | | | | 1240 | 1400 | | |
| | 355M | 220/250 | | | | 1225 | 1970 | 745 | | | | 1570 | 1800 | | |
| | 355(6KV) | 250 | | | | 1105 | 2530 | 720 | | | | 1820 | 2160 | | |

DMC200-320 E Curve n=1450r/min

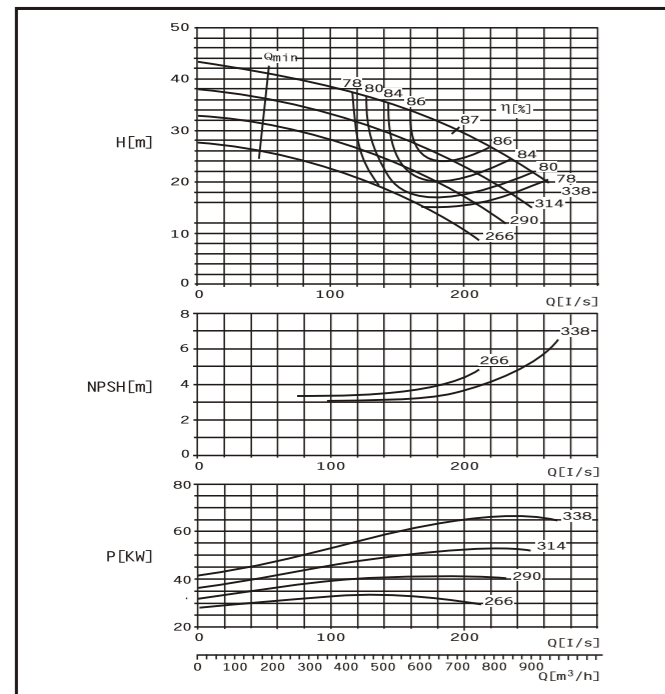

DMC200-320 F Curve n=1450r/min

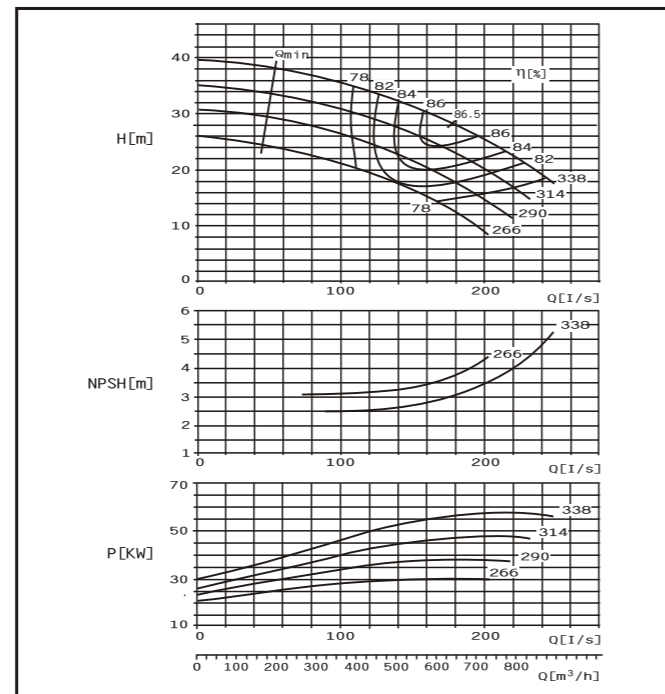

DMC200-420 E Curve n=1450r/min

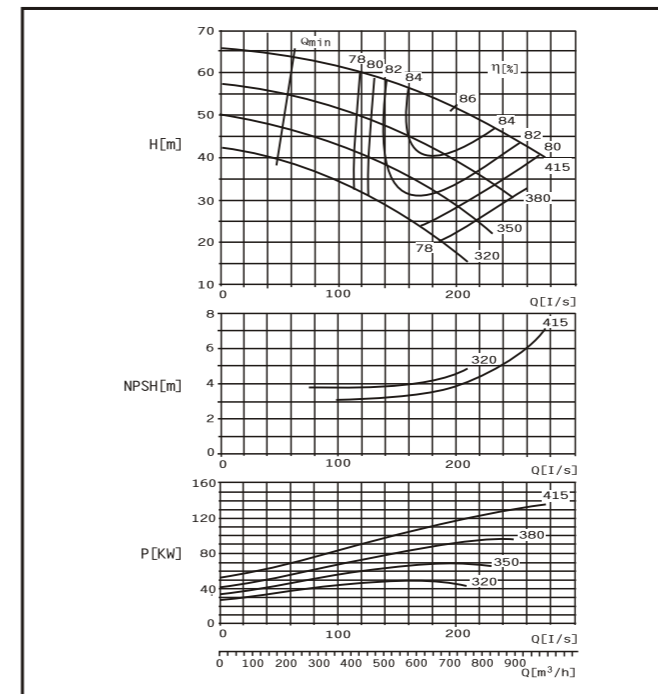

DMC200-420 F Curve n=1450r/min

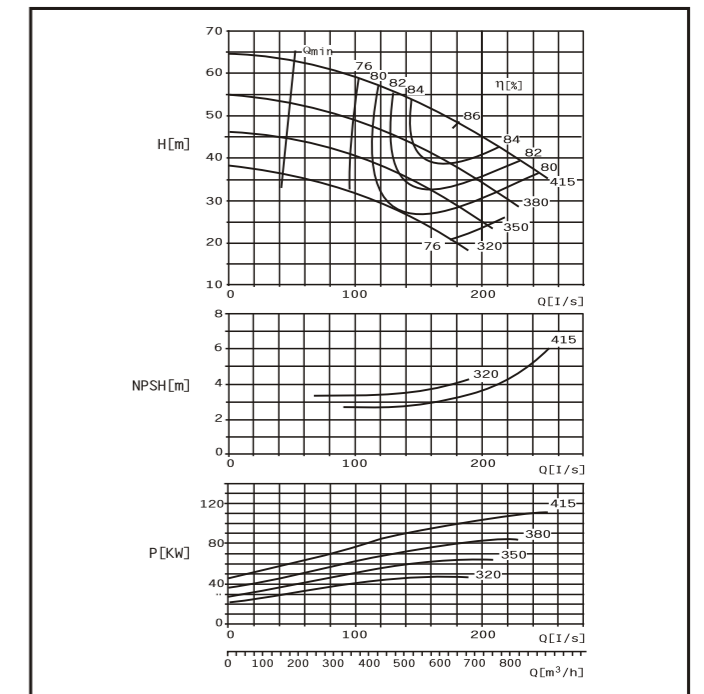

DMC卧式泵安装尺寸图 Installing dimensions of DMC pumps

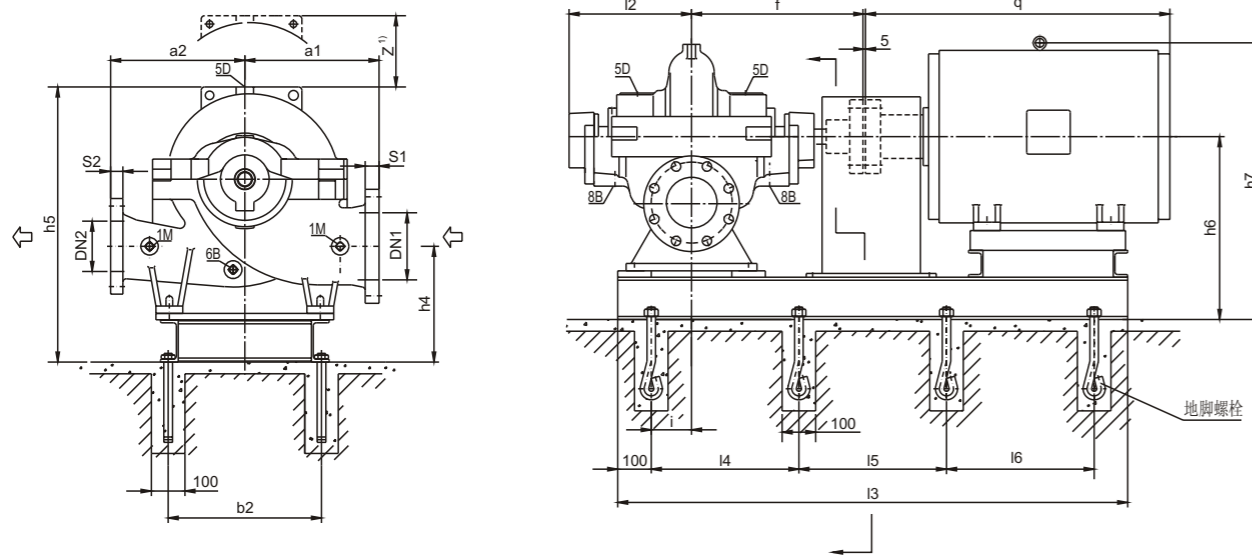

连接尺寸 connection dimensions:

- 1M 压力表 Rp1/2 1M pressure gauge Rp1/2
- 6B 排液孔 Rp1/2 6B drain plug Rp1/2
- 5D 排气孔 Rp1/2 5D air vent Rp1/2
- 8B 漏液排出孔 Rp3/4 8B drain plug Rp3/4

Z¹ 拆卸转子所需最小空间尺寸

Z¹ Min.dimensions of disassembling rotor assembly

法兰钻孔示意图

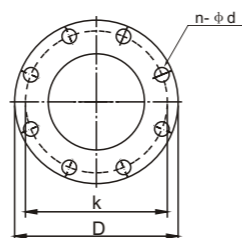

参数表 Standard performance

| 泵型号 Type | 流量 Capacity Q | 扬程 Head m | 转速 Speed r/min | 轴功率 Shaft power kW | 效率 eff η % | 有效汽 蚀余量 NPSHa m | 电机功率 Motor power kW | 叶轮参 考直径 D(mm) |
|-----------------|---------------------|-----------------|----------------------|-----------------------------|------------------|--------------------------|------------------------------|---------------------|
| DMC 200-320E | 556 | 154.4 | 34 | 60 | 86 | 3.8 | 75 | 338 |
| | 695 | 193 | 30 | 64.9 | 87.5 | | | |
| | 834 | 231.7 | 25 | 67.2 | 84.5 | | | |
| | 518 | 144 | 29 | 48.8 | 84 | | | |
| | 648 | 180 | 25.5 | 52 | 86.5 | | | |
| | 778 | 216 | 21.3 | 54 | 83.5 | | | |
| DMC 200-320F | 481 | 133.4 | 25 | 40.7 | 80.5 | | | |
| | 601 | 167 | 21.3 | 41 | 85 | | | |
| | 720 | 200 | 17.2 | 42.3 | 80 | | | |
| | 440 | 122.2 | 18.9 | 29 | 78 | | | |
| | 550 | 152.8 | 17 | 32.3 | 79 | | | |
| | 612 | 170 | 15.3 | 32.9 | 77.5 | | | |
| DMC 200-420E | 510 | 141.7 | 32.3 | 52.7 | 85.2 | | | |
| | 637 | 176.9 | 28 | 56.2 | 86.5 | | | |
| | 765 | 212.5 | 23.4 | 58.0 | 84 | | | |
| | 475 | 132 | 28.5 | 44 | 83.8 | | | |
| | 594 | 165 | 24.5 | 46.1 | 86 | | | |
| | 713 | 198 | 20 | 47.9 | 82.9 | | | |
| DMC 200-420F | 445 | 123.6 | 23.8 | 35.6 | 81.3 | | | |
| | 558 | 155 | 21 | 38.0 | 84 | | | |
| | 670 | 186 | 17.2 | 38.4 | 81.8 | | | |
| | 412 | 114.4 | 20 | 28.8 | 78 | | | |
| | 515 | 143.1 | 17 | 29 | 82 | | | |
| | 595 | 165.3 | 14.2 | 29.5 | 78 | | | |

参数表 Standard performance

| 泵型号 Type | 流量 Capacity Q | 扬程 Head m | 转速 Speed r/min | 轴功率 Shaft power kW | 效率 eff η % | 有效汽 蚀余量 NPSHa m | 电机功率 Motor power kW | 叶轮参 考直径 D(mm) |
|-----------------|---------------------|-----------------|----------------------|-----------------------------|------------------|--------------------------|------------------------------|---------------------|
| DMC 200-420E | 567 | 157.5 | 57 | 104 | 84.5 | | | |
| | 709 | 197 | 52 | 116 | 86.5 | | | |
| | 850 | 236.1 | 47 | 129 | 84.5 | | | |
| | 504 | 140 | 47.5 | 79.1 | 82.5 | | | |
| | 630 | 175 | 42.5 | 86.3 | 84.5 | | | |
| | 756 | 210 | 37.5 | 93.1 | 83 | | | |
| DMC 200-420F | 458 | 127.2 | 40 | 62 | 80.5 | | | |
| | 572 | 159 | 35.5 | 66.7 | 83 | | | |
| | 687 | 190.8 | 30 | 68.8 | 81.6 | | | |
| | 409 | 113.6 | 32.5 | 45.8 | 79 | | | |
| | 511 | 142 | 27.5 | 49 | 81 | | | |
| | 613 | 170 | 24 | 50.1 | 80 | | | |
| DMC 200-420E | 518 | 144 | 54 | 90.8 | 84 | | | |
| | 648 | 180 | 48.5 | 99.1 | 85.5 | | | |
| | 778 | 216 | 42 | 107 | 83.5 | | | |
| | 467 | 130 | 45 | 69.8 | 82 | | | |
| | 583 | 162 | 40.5 | 76.6 | 84 | | | |
| | 700 | 195 | 35 | 81.9 | 81.5 | | | |
| DMC 200-420F | 423 | 118 | 38 | 54.8 | 80 | | | |
| | 530 | 147 | 34.5 | 60.6 | 82 | | | |
| | 635 | 176 | 29 | 63.1 | 79.5 | | | |
| | 375 | 104 | 31.5 | 41.5 | 77.5 | | | |
| | 468 | 130 | 28 | 45.8 | 78 | | | |
| | 562 | 156 | 24 | 47.5 | 77.3 | | | |

主要外型尺寸 pump outline size

| 泵型号 type | 法兰尺寸 flange size | | | | | | | | | | 泵尺寸 pump size | | | | | 泵重量W.T | | |
|-------------|-------------------|----|-----|-----|--------|--------------------|----|-----|-----|--------|---------------|-----|-----|------|-----|----------------|-------|-------|
| | 进口法兰 inlet flange | | | | | 出口法兰 outlet flange | | | | | a1 | a2 | f | h5≤ | 12 | z ¹ | 净重N.T | 湿重G.T |
| | DN1 | S1 | K | D | n-φd | DN2 | S2 | K | D | n-φd | | | | | | | | |
| 200-320 | 250 | 32 | 355 | 410 | 12-φ25 | 200 | 30 | 295 | 340 | 12-φ22 | 450 | 450 | 590 | 1240 | 399 | 570 | 450 | 530 |
| 200-420 | 250 | 32 | 355 | 410 | 12-φ25 | 200 | 30 | 295 | 340 | 12-φ22 | 500 | 500 | 590 | 1240 | 399 | 620 | 520 | 615 |

电机尺寸——Y型电机 Motor size

| 泵型号 Type | 电机 Motor | | b2 | h4 | h6 | h7 | l3 | l4 | l5 | i | q | 电机重量(kg) Motor W · T | 底座参考 重量(kg) Baseplate W · T | 地脚螺栓 anchor bolt | |
|-------------|----------|------------------|------|-----|-----|-----|-----|------|------|-----|------|-------------------------|-----------------------------------|---------------------|-----------|
| | 型号 Type | 功率 Power (kW) | | | | | | | | | | | | | |
| 200-320 | 200-320 | 225S | 37 | 560 | 380 | 620 | 925 | 1470 | 635 | 150 | 820 | 284 | 190 | 6-M20×400 | |
| | | 225M | 45 | | | | | | | | 845 | 320 | | | |
| | | 250M | 55 | | | | | | | | 930 | 427 | | | |
| | | 280S | 75 | | | | | | | | 1000 | 562 | | | |
| | | 280M | 90 | | | | | | | | 1050 | 667 | | | |
| | | 315S | 110 | | | | | | | | 1270 | 1000 | | | |
| | 200-420 | 200-420 | 315M | 132 | 560 | 380 | 620 | 980 | 1630 | 715 | 150 | 1340 | 1100 | 410 | 6-M20×400 |
| | | | 315L | 160 | | | | | | | | 1750 | 775 | | |
| | | | 315M | 132 | | | | | | | | 1800 | 800 | | |
| | | | 315L | 160 | | | | | | | | 1830 | 815 | | |
| | | | 315M | 132 | | | | | | | | 1340 | 1100 | | |
| | | | 315L | 160 | | | | | | | | 1340 | 1240 | | |

DMC200-520 E Curve n=1450r/min

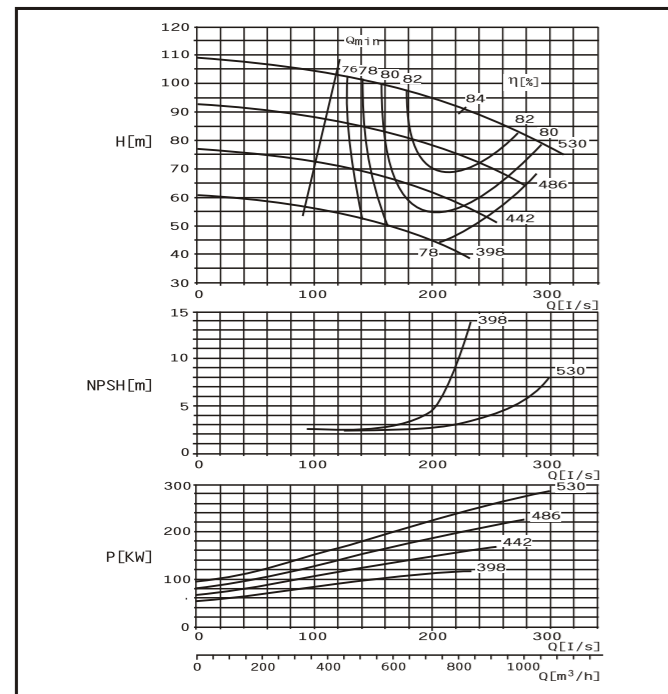

DMC200-520 F Curve n=1450r/min

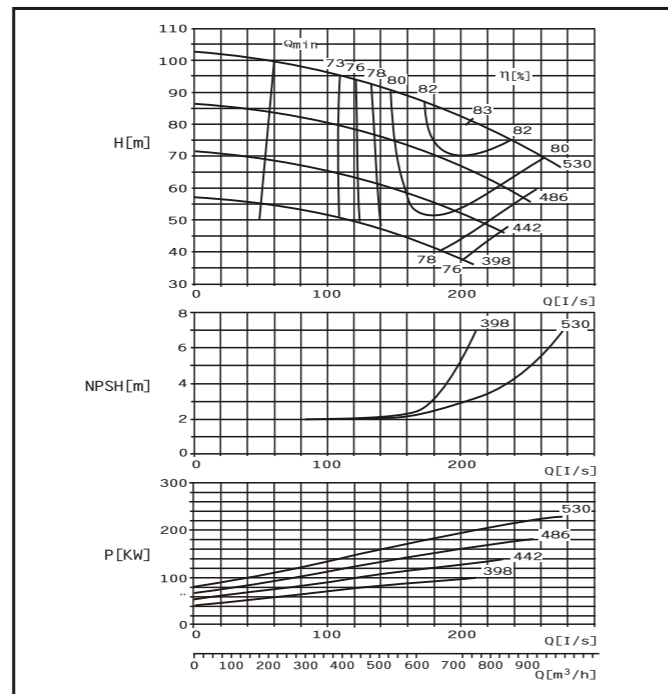

DMC200-670 E Curve n=1450r/min

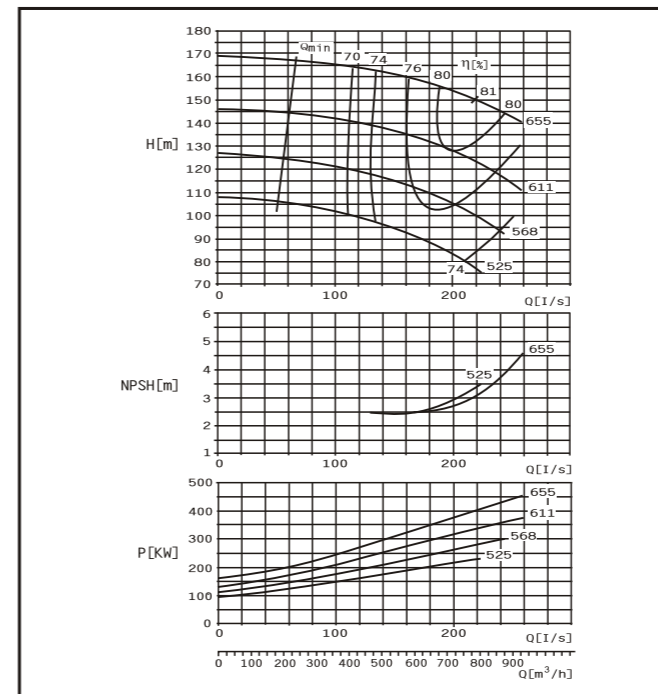

DMC200-670 F Curve n=1450r/min

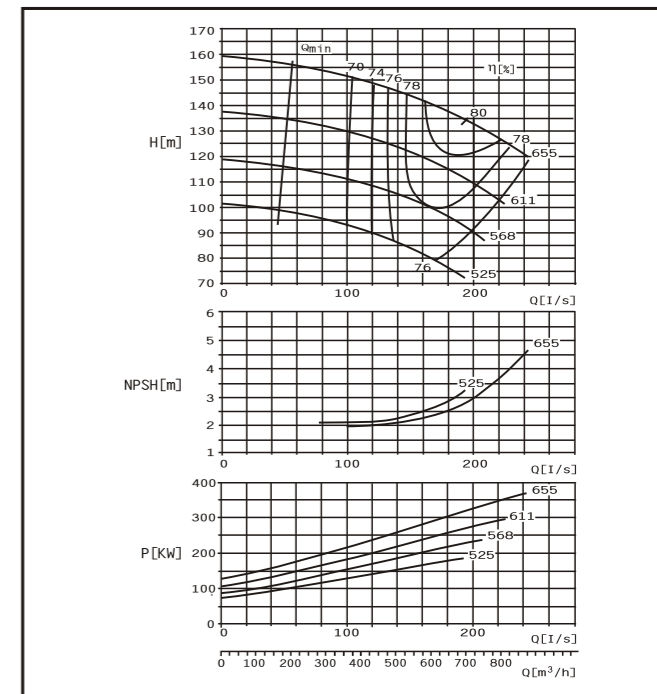

CMD卧式泵安装尺寸图 Installing dimensions of CMD pumps

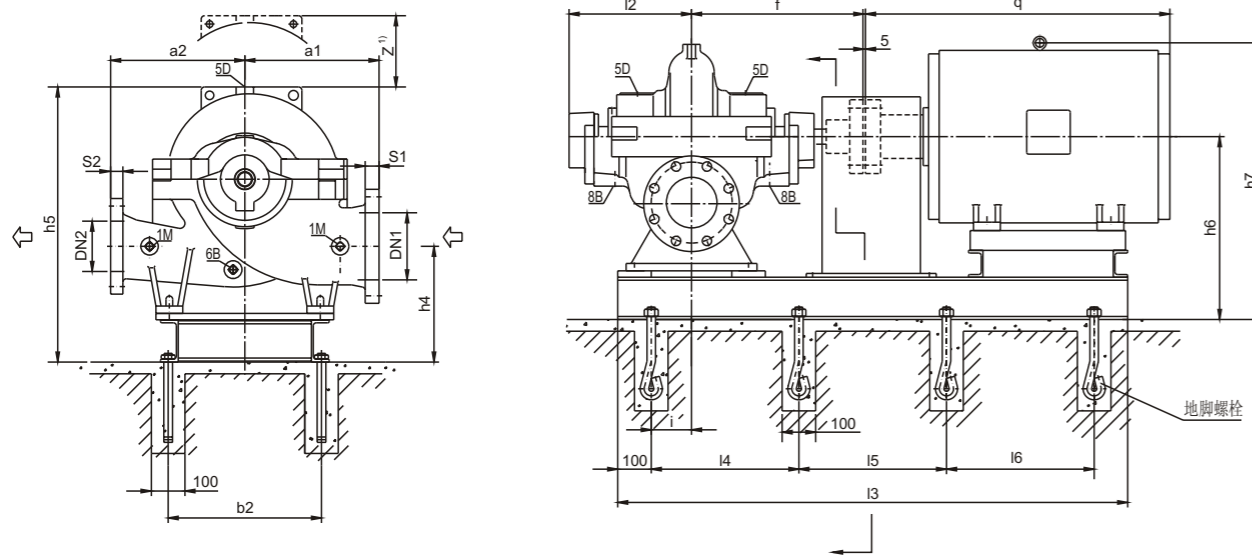

连接尺寸 connection dimensions:

- 1M 压力表 Rp1/2 1M pressure gauge Rp1/2
- 6B 排液孔 Rp1/2 6B drain plug Rp1/2
- 5D 排气孔 Rp1/2 5D air vent Rp1/2
- 8B 漏液排出孔 Rp3/4 8B drain plug Rp3/4

Z¹⁾ 拆卸转子所需最小空间尺寸

Z¹⁾ Min.dimensions of disassembling rotor assembly

法兰钻孔示意图

31

参数表 Standard performance

| 泵型号 Type | 流量 Capacity Q m³/h l/s | 扬程 Head m | 转速 Speed r/min | 轴功率 Shaft power kW | 效率 eff η % | 有效汽 蚀余量 NPSHa m | 电机功率 Motor power kW | 叶轮参 考直径 D(mm) |
|-----------------|------------------------------------|-----------------|----------------------|-----------------------------|---------------------|--------------------------|------------------------------|---------------------|
| DMC 200-520E | 654 | 181.7 | 97 | 210 | 82.2 | 4.0 | 280 | 530 |
| | 817 | 227 | 91 | 241 | 84 | | 220 | 486 |
| | 980 | 272.2 | 83 | 272 | 81.5 | | 250 | 442 |
| | 605 | 168 | 82.5 | 170 | 80.2 | | 185 | 398 |
| | 756 | 210 | 76.5 | 192 | 83 | | 132 | 350 |
| | 907 | 252 | 70 | 215 | 80.4 | | 117 | 315 |
| | 518 | 144 | 52.3 | 98 | 75.5 | | 88 | 250 |
| | 648 | 180 | 47.5 | 107 | 78.5 | | 88 | 220 |
| | 778 | 216.1 | 42 | 117 | 76.2 | | 80 | 200 |
| | 588 | 163.2 | 88 | 175 | 80.3 | | 220 | 486 |
| DMC 200-520F | 734 | 204 | 81.7 | 197 | 83 | 250 | 530 | |
| | 880 | 244.8 | 73.2 | 219 | 80.3 | 250 | 486 | |
| | 556 | 154.4 | 74 | 141 | 79.6 | 185 | 442 | |
| | 695 | 193 | 68 | 159 | 81 | 160 | 400 | |
| | 834 | 231.7 | 60 | 172 | 79.3 | 110 | 398 | |
| | 524 | 145.6 | 60 | 109 | 78.5 | 110 | 350 | |
| | 655 | 182 | 55 | 123 | 80 | 110 | 315 | |
| | 786 | 218.3 | 48.8 | 134 | 78 | 110 | 280 | |
| | 478 | 132.8 | 48 | 81 | 76.8 | 110 | 250 | |
| | 598 | 166 | 43.5 | 91 | 78 | 110 | 220 | |

参数表 Standard performance

| 泵型号 Type | 流量 Capacity Q m³/h l/s | 扬程 Head m | 转速 Speed r/min | 轴功率 Shaft power kW | 效率 eff η % | 有效汽 蚀余量 NPSHa m | 电机功率 Motor power kW | 叶轮参 考直径 D(mm) |
|-----------------|------------------------------------|-----------------|----------------------|-----------------------------|---------------------|--------------------------|------------------------------|---------------------|
| DMC 200-670E | 634 | 176 | 157.5 | 350 | 77.7 | 3.6 | 500 | 655 |
| | 792 | 220 | 150 | 404 | 80 | | 400 | 611 |
| | 936 | 260 | 140 | 457 | 78.2 | | 315 | 568 |
| | 596 | 165.6 | 134.5 | 285 | 76.7 | | 250 | 525 |
| | 745 | 206.9 | 127 | 328 | 78.5 | | 200 | 486 |
| | 894 | 248.3 | 114.5 | 367 | 76 | | 185 | 442 |
| | 562 | 156.1 | 114.5 | 231 | 76 | | 132 | 398 |
| | 702 | 195 | 107 | 266 | 77 | | 117 | 350 |
| | 842 | 234 | 95.5 | 293 | 74.8 | | 88 | 315 |
| | 527 | 146.4 | 95.5 | 183 | 74.8 | | 80 | 280 |
| DMC 200-670F | 576 | 160 | 142 | 289 | 77.2 | 3.4 | 400 | 655 |
| | 720 | 200 | 132.5 | 329 | 79 | | 315 | 611 |
| | 864 | 240 | 120 | 372 | 76 | | 250 | 568 |
| | 530 | 147.2 | 123 | 231 | 76.8 | | 200 | 486 |
| | 662 | 183.9 | 114.5 | 263 | 78.5 | | 185 | 442 |
| | 796 | 220.8 | 104 | 296 | 76 | | 160 | 400 |
| | 493 | 136.9 | 106 | 187 | 76.1 | | 110 | 398 |
| | 616 | 171.1 | 98.5 | 212 | 78 | | 110 | 350 |
| | 720 | 200 | 90 | 232 | 76 | | 110 | 315 |
| | 455 | 126.4 | 90 | 149 | 74.8 | | 80 | 280 |

主要外型尺寸 pump outline size

| 泵型号 type | 法兰尺寸 flange size | | | | | | | | 泵尺寸 pump size | | | | | 泵重量W.T | | | | |
|-------------|-------------------|----|-----|-----|--------------------|-----|----|-----|---------------|--------|-----|-----|-----|-----------------|-------|-------|-----|------|
| | 进口法兰 inlet flange | | | | 出口法兰 outlet flange | | | | a1 | a2 | f | h5≤ | 12 | z ¹⁾ | 净重N.T | 湿重G.T | | |
| 200-520 | DN1 | S1 | K | D | n-φd | DN2 | S2 | K | D | n-φd | 600 | 500 | 655 | 1240 | 464 | 740 | 840 | 955 |
| 200-670 | 250 | 40 | 370 | 430 | 12-φ30 | 200 | 36 | 310 | 365 | 12-φ25 | 650 | 550 | 655 | 1240 | 464 | 860 | 990 | 1130 |

电机尺寸——Y型电机 Motor size

| 泵型号 Type | 电机Motor | | b2 | h4 | h6 | h7 | l3 | l4 | l5 | l6 | i | q | 电机重量 Motor W · T (kg) | 底座参考 重量(kg) Baseplate W · T | 地脚螺栓 anchor bolt |
|----------|----------|-----------------|-----|-----|-----|------|------|-----|----|-----|------|------|-----------------------------|-----------------------------------|---------------------|
| | 型号 Type | 功率Power (kW) | | | | | | | | | | | | | |
| 200-520 | 315S | 110 | 700 | 440 | 740 | 1290 | 1810 | 805 | - | 150 | 1270 | 1000 | 410 | 6-M24×500 | |
| | 315M | 132 | | | | | | | | | | | | | |
| | 315L | 160/200 | | | | | | | | | | | | | |
| | 355(6KV) | 220-315 | | | | | | | | | | | | | |
| 200-670 | 315L | 160-200 | 700 | 430 | 780 | 1330 | 1890 | 845 | - | 150 | 1340 | 1240 | 440 | 8-M24×500 | |
| | 355(6KV) | 220-315 | | | | | | | | | | | | | |
| | 400(6KV) | 355-500 | | | | | | | | | | | | | |
| | 400(6KV) | 355-500 | | | | | | | | | | | | | |

32

DMC250-370 E Curve n=1450r/min

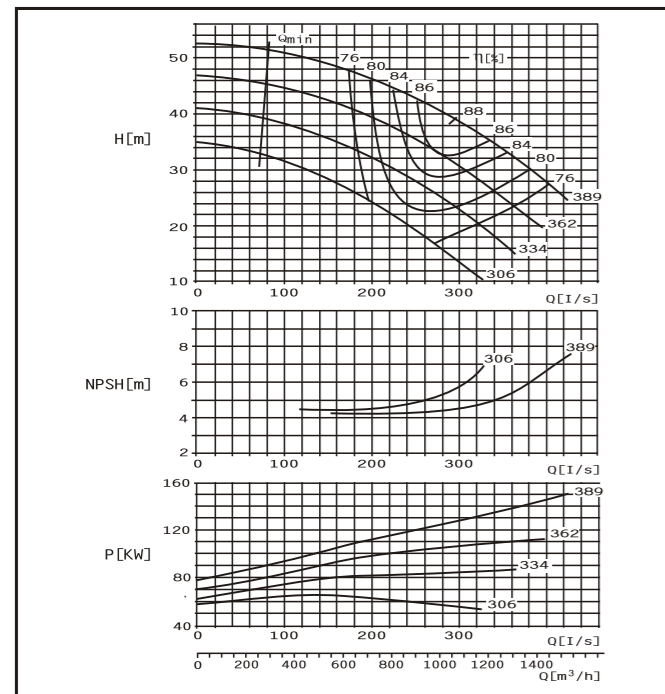

DMC250-370 F Curve n=1450r/min

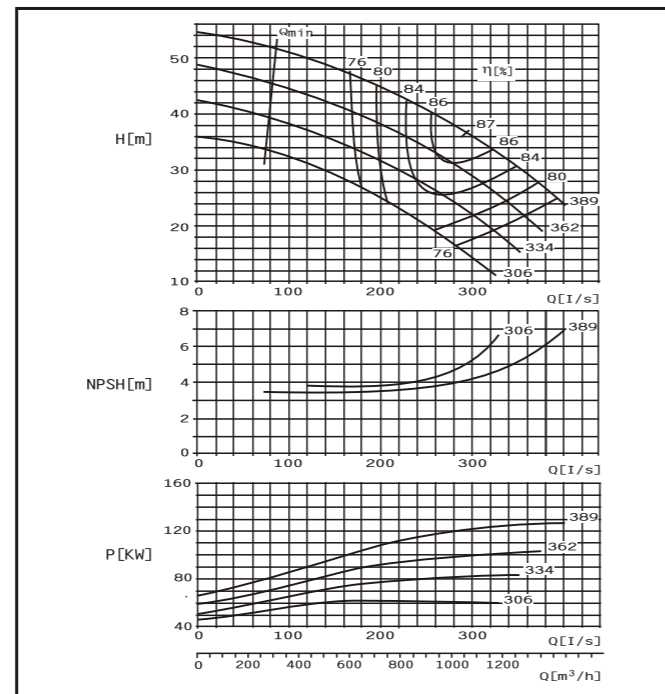

DMC卧式泵安装尺寸图 Installing dimensions of CMD pumps

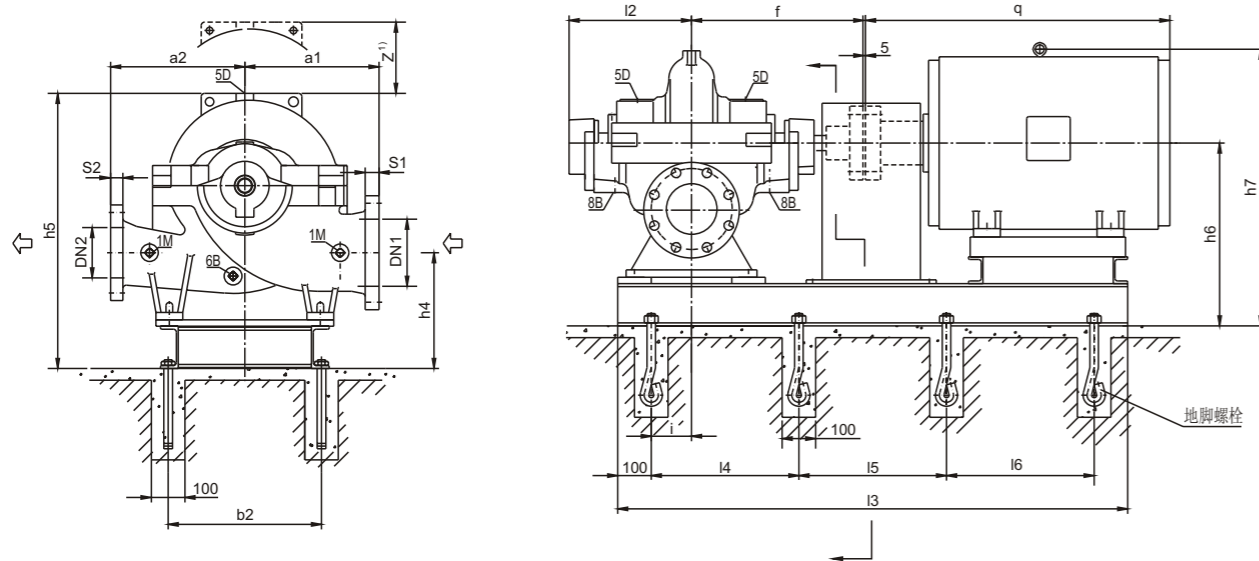

连接尺寸 connection dimensions:

- 1M 压力表 Rp1/2 1M pressure gauge Rp1/2
- 6B 排液孔 Rp1/2 6B drain plug Rp1/2
- 5D 排气孔 Rp1/2 5D air vent Rp1/2
- 8B 漏液排出孔 Rp3/4 8B drain plug Rp3/4

Z¹⁾ 拆卸转子所需最小空间尺寸

Z¹⁾ Min.dimensions of disassembling rotor assembly

法兰钻孔示意图

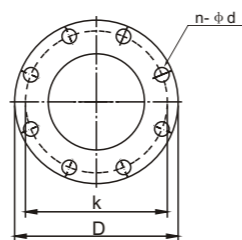

DMC250-480 E Curve n=1450r/min

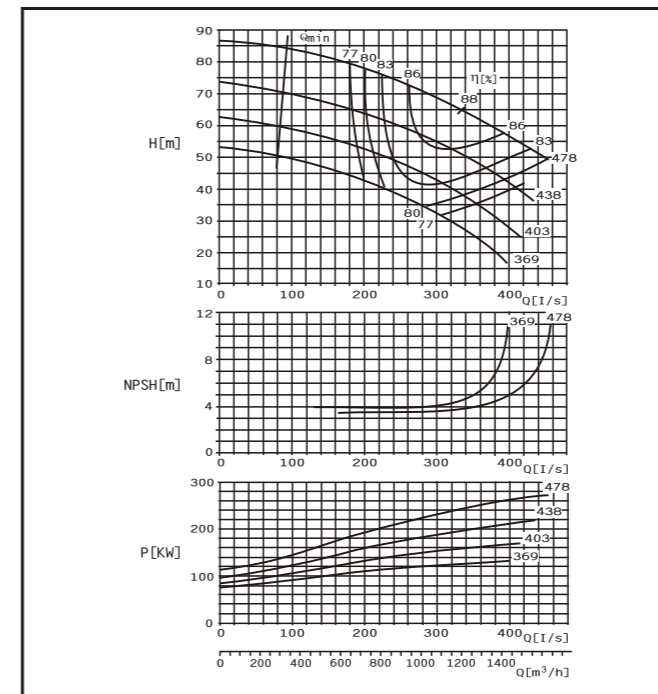

DMC250-480 F Curve n=1450r/min

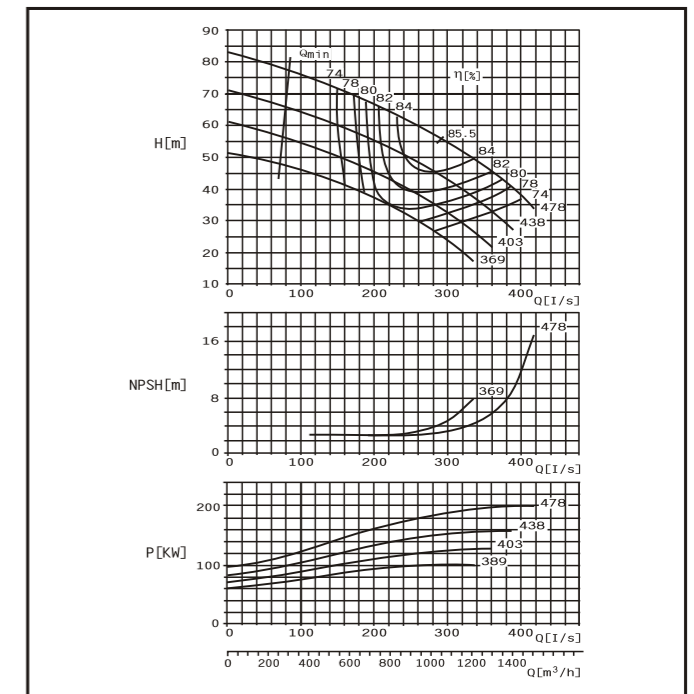

参数表 Standard performance

| 泵型号 Type | 流量 Capacity Q | | 扬程 Head m | 转速 Speed r/min | 轴功率 Shaft power kW | 效率 eff η % | 有效汽 蚀余量 NPSHa m | 电机功率 Motor power kW | 叶轮参 考直径 D(mm) |
|-----------------|---------------------|-------|-----------------|----------------------|-----------------------------|------------------|--------------------------|------------------------------|---------------------|
| | m³/h | l/s | | | | | | | |
| DMC 250-370E | 840 | 233.3 | 44 | 1450 | 118 | 85.3 | 4.7 | 160 | 389 |
| | 1051 | 292 | 39 | | 127 | 88 | | | |
| | 1260 | 350 | 33.5 | | 137 | 84 | | | |
| | 795 | 220.8 | 37.5 | | 99 | 82.3 | | | |
| | 994 | 276.1 | 33 | | 104 | 86 | | | |
| | 1192 | 331.2 | 27.7 | | 109 | 82.3 | | | |
| DMC 250-370F | 755 | 209.7 | 31.5 | 1450 | 83 | 78 | 5.0 | 90 | 334 |
| | 943 | 261.9 | 27 | | 83.6 | 83 | | | |
| | 1131 | 314.4 | 21 | | 83.6 | 77.5 | | | |
| | 756 | 210 | 23 | | 62.3 | 76 | | | |
| | 871 | 242 | 20 | | 61.2 | 77.5 | | | |
| | 1008 | 280 | 16 | | 57.8 | 76 | | | |
| DMC 250-480E | 823 | 228.6 | 42.3 | 1450 | 112 | 84.5 | 4.7 | 132 | 389 |
| | 1029 | 286 | 37 | | 119 | 87 | | | |
| | 1235 | 343 | 31 | | 124 | 84.3 | | | |
| | 775 | 215.3 | 37 | | 94.9 | 82.3 | | | |
| | 968 | 268.9 | 32 | | 98.1 | 86 | | | |
| | 1162 | 322.8 | 27 | | 103.6 | 82.5 | | | |
| DMC 250-480F | 732 | 203.3 | 32 | 1450 | 79.7 | 80 | 4.7 | 90 | 334 |
| | 914 | 253.9 | 27 | | 80 | 84 | | | |
| | 1097 | 304.8 | 22 | | 82.2 | 80 | | | |
| | 680 | 188.9 | 25.6 | | 61.6 | 77 | | | |
| | 850 | 236.1 | 22 | | 62.1 | 82 | | | |
| | 1020 | 283.3 | 17 | | 61.3 | 77 | | | |

参数表 Standard performance

| 泵型号 Type | 流量 Capacity Q | | 扬程 Head m | 转速 Speed r/min | 轴功率 Shaft power kW | 效率 eff η % | 有效汽 蚀余量 NPSHa m | 电机功率 Motor power kW | 叶轮参 考直径 D(mm) |
|-----------------|---------------------|-------|-----------------|----------------------|-----------------------------|------------------|--------------------------|------------------------------|---------------------|
| | m³/h | l/s | | | | | | | |
| DMC 250-480E | 938 | 260.7 | 73.5 | 1450 | 222 | 84.8 | 4.1 | 280 | 478 |
| | 1173 | 326 | 66 | | 239 | 88 | | | |
| | 1408 | 391 | 58 | | 262 | 85 | | | |
| | 864 | 240 | 60.5 | | 166 | 82.8 | | | |
| | 1080 | 300 | 55 | | 188 | 86 | | | |
| | 1296 | 360 | 47.5 | | 202 | 83 | | | |
| DMC 250-480F | 800 | 222.4 | 50 | 1450 | 136 | 80 | 4.0 | 185 | 403 |
| | 1000 | 278 | 45.5 | | 149 | 83 | | | |
| | 1200 | 333.6 | 38 | | 160 | 77.6 | | | |
| | 743 | 206.4 | 42 | | 110 | 77 | | | |
| | 929 | 258 | 37.5 | | 119 | 80 | | | |
| | 1115 | 309.6 | 32 | | 126 | 77 | | | |

主要外型尺寸 pump outline size

| 泵型号 type | 法兰尺寸 flange size | | | | | | | | | | 泵尺寸 pump size | | | | 泵重量W.T | | | |
|-------------|-------------------|----|-----|-----|--------|--------------------|----|-----|-----|--------|---------------|-----|-----|------|--------|-----------------|-------|-------|
| | 进口法兰 inlet flange | | | | | 出口法兰 outlet flange | | | | | a1 | a2 | f | h5≤ | 12 | z ¹⁾ | 净重N.T | 湿重G.T |
| | DN1 | S1 | K | D | n-φd | DN2 | S2 | K | D | n-φd | | | | | | | | |
| 250-370 | 300 | 36 | 400 | 465 | 12-φ22 | 250 | 32 | 350 | 410 | 12-φ22 | 500 | 500 | 655 | 1275 | 464 | 640 | 665 | 790 |
| 250-480 | | | 410 | | 12-φ26 | | | 355 | | 12-φ25 | 550 | 550 | 730 | | 515 | 710 | 830 | 975 |

电机尺寸——Y型电机 Motor size

| 泵型号 Type | 电机Motor | | b2 | h4 | h6 | h7 | l3 | l4 | l5 | l6 | i | q | 电机重量 Motor W · T (kg) | 底座参考 重量(kg) Baseplate W · T | 地脚螺栓 anchor bolt |
|-------------|----------|-----------------|-----|-----|-----|------|------|-----|----|-----|------|------|-----------------------------|-----------------------------------|---------------------|
| | 型号 Type | 功率Power (kW) | | | | | | | | | | | | | |
| 250-370 | 280S | 75 | 700 | 480 | 780 | 1140 | 1690 | 745 | - | 150 | 1000 | 562 | 250 | 6- M24×500 | |
| | 280M | 90 | | | | | | | | | | | | | |
| | 315S | 110 | | | | | | | | | | | | | |
| | 315M | 132 | | | | | | | | | | | | | |
| | 315L | 160 | | | | | | | | | | | | | |
| 250-480 | 315S | 110 | 700 | 500 | 800 | 1350 | 1950 | 875 | - | 210 | 1270 | 1000 | 250 | 6- M24×500 | |
| | 315M | 132 | | | | | | | | | | | | | |
| | 315L | 160-200 | | | | | | | | | | | | | |
| | 355(6KV) | 220-315 | | | | | | | | | | | | | |
| | | | | | | | | | | | | | | | |

DMC250-600 E Curve n=1450r/min

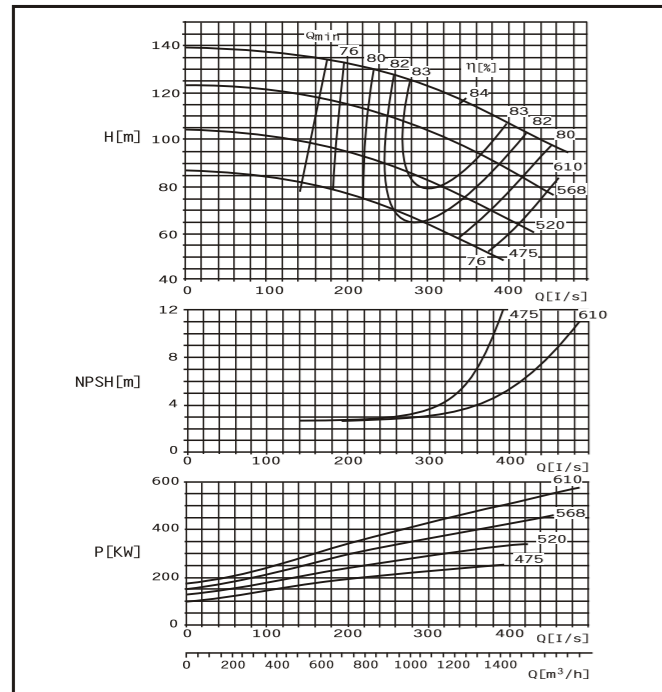

DMC250-600 F Curve n=1450r/min

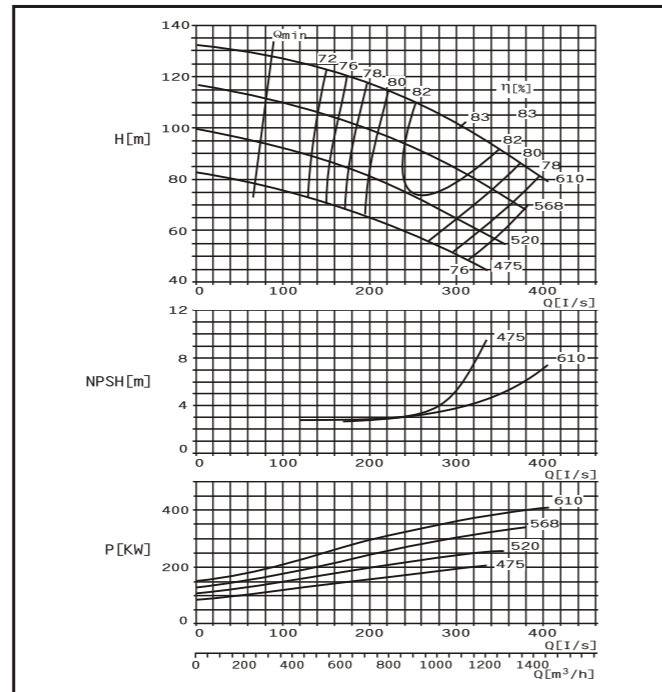

DMC250-710 E Curve n=1450r/min

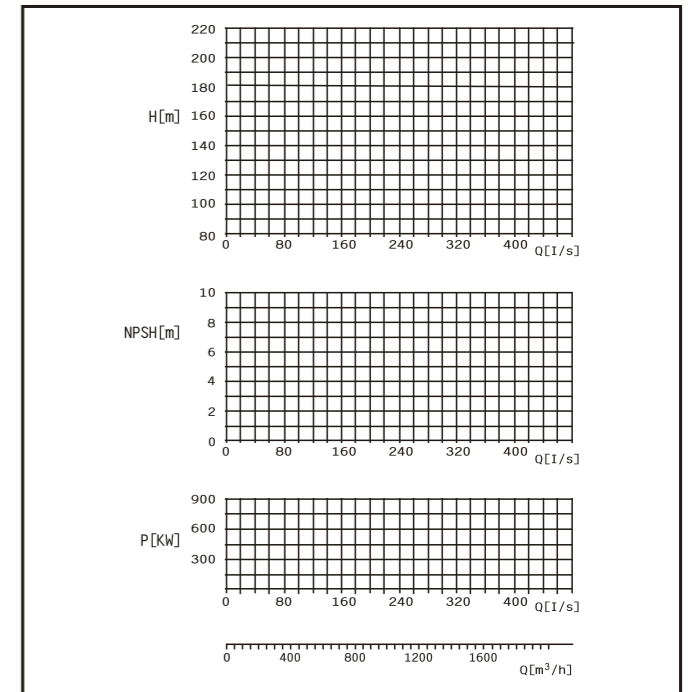
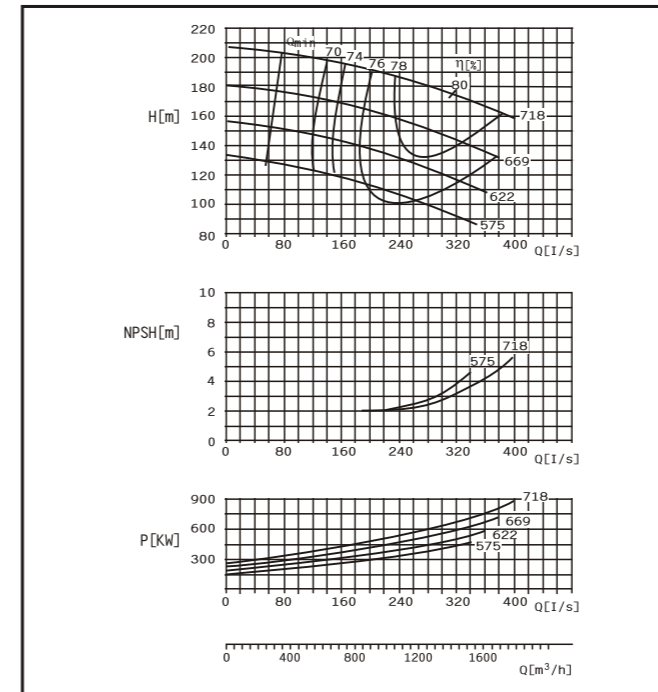

DMC卧式泵安装尺寸图 Installing dimensions of DMC pumps

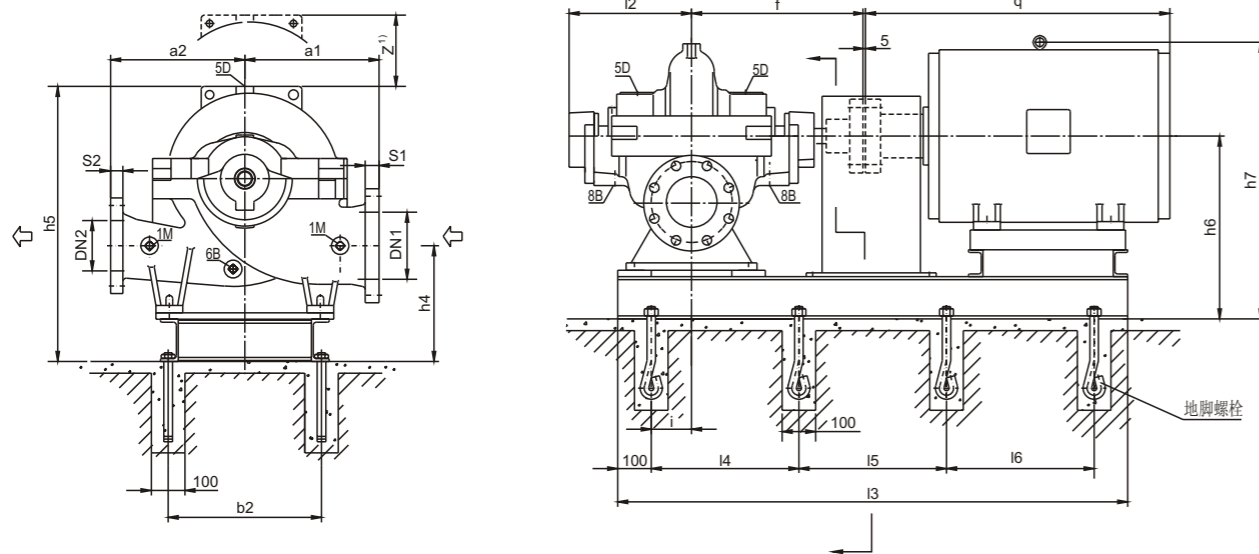

法兰钻孔示意图

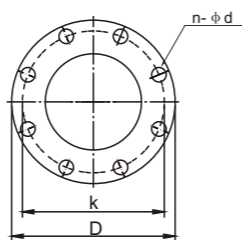

连接尺寸 connection dimensions:

- 1M 压力表 Rp1/2 1M pressure gauge Rp1/2
- 6B 排液孔 Rp1/2 6B drain plug Rp1/2
- 5D 排气孔 Rp1/2 5D air vent Rp1/2
- 8B 漏液排出孔 Rp3/4 8B drain plug Rp3/4

Z¹ 拆卸转子所需最小空间尺寸

Z¹ Min.dimensions of disassembling rotor assembly

参数表 Standard performance

| 泵型号 Type | 流量 Capacity Q | | 扬程 Head m | 转速 Speed r/min | 轴功率 Shaft power kW | 效率 eff η % | 有效汽 蚀余量 NPSHa m | 电机功率 Motor power kW | 叶轮参 考直径 D(mm) |
|-----------------|---------------------|-------|-----------------|----------------------|-----------------------------|------------------|--------------------------|------------------------------|---------------------|
| | m³/h | l/s | | | | | | | |
| DMC 250-600E | 994 | 276.1 | 126 | 1450 | 411 | 83 | 4.6 | 560 | 610 |
| | 1242 | 345 | 116 | | | | | | |
| | 1490 | 413.9 | 105 | | | | | | |
| | 933 | 259.2 | 108 | | | | | | |
| | 1166 | 323.9 | 100 | | | | | | |
| | 1400 | 388.9 | 90 | | | | | | |
| DMC 250-600F | 867 | 240.8 | 90 | 1450 | 262 | 81.3 | 3.7 | 400 | 610 |
| | 1084 | 301 | 83 | | | | | | |
| | 1300 | 361.1 | 73.5 | | | | | | |
| | 800 | 222.2 | 74 | | | | | | |
| | 1000 | 277.8 | 66 | | | | | | |
| | 1200 | 333.3 | 60 | | | | | | |
| DMC 250-710E | 835 | 232 | 114 | 1450 | 320 | 81.2 | 3.6 | 315 | 568 |
| | 1044 | 290 | 104 | | | | | | |
| | 1253 | 348 | 91.5 | | | | | | |
| | 772 | 214.4 | 98 | | | | | | |
| | 965 | 268.1 | 90 | | | | | | |
| | 1158 | 321.6 | 80 | | | | | | |
| DMC 250-710F | 700 | 194.4 | 80.3 | 1450 | 192 | 80 | 3.3 | 250 | 520 |
| | 875 | 243.1 | 74.5 | | | | | | |
| | 1050 | 291.7 | 66.0 | | | | | | |
| | 640 | 177.7 | 67.5 | | | | | | |
| | 800 | 222.2 | 62.0 | | | | | | |
| | 960 | 266.7 | 56.5 | | | | | | |

参数表 Standard performance

| 泵型号 Type | 流量 Capacity Q | | 扬程 Head m | 转速 Speed r/min | 轴功率 Shaft power kW | 效率 eff η % | 有效汽 蚀余量 NPSHa m | 电机功率 Motor power kW | 叶轮参 考直径 D(mm) |
|-----------------|---------------------|-----|-----------------|----------------------|-----------------------------|------------------|--------------------------|------------------------------|---------------------|
| | m³/h | l/s | | | | | | | |
| DMC 250-710E | 904 | 251 | 184 | 1450 | 579 | 78.3 | 3.4 | 800 | 718 |
| | 1130 | 314 | 175 | | | | | | |
| | 1356 | 377 | 164 | | | | | | |
| | 782 | 217 | 161 | | | | | | |
| | 978 | 272 | 152 | | | | | | |
| | 1174 | 326 | 141 | | | | | | |
| DMC 250-710F | 738 | 205 | 136 | 1450 | 358 | 76.5 | 3.2 | 500 | 622 |
| | 922 | 256 | 128 | | | | | | |
| | 1106 | 307 | 118 | | | | | | |
| | 692 | 192 | 113 | | | | | | |
| | 865 | 240 | 106 | | | | | | |
| | 1038 | 288 | 99 | | | | | | |

主要外型尺寸 pump outline size

| 泵型号 type | 法兰尺寸 flange size | | | | | | | | | 泵尺寸 pump size | | | | | | 泵重量W.T | | |
|-------------|-------------------|----|-----|-----|--------|--------------------|----|-----|-----|---------------|-----|-----|-----|------|----------------|--------|-------|------|
| | 进口法兰 inlet flange | | | | | 出口法兰 outlet flange | | | | a1 | a2 | f | h5≤ | 12 | z ¹ | 净重N.T | 湿重G.T | |
| | DN1 | S1 | K | D | n-φd | DN2 | S2 | K | D | | | | | | | | | n-φd |
| 250-600 | 300 | 42 | 430 | 490 | 16-φ30 | 250 | 40 | 370 | 430 | 12-φ30 | 650 | 550 | 730 | 1275 | 515 | 830 | 1215 | 1395 |
| 250-710 | 300 | 42 | 430 | 490 | 16-φ30 | 250 | 40 | 370 | 430 | 12-φ30 | 750 | 650 | 810 | 1430 | 585 | 960 | 1580 | 1855 |

电机尺寸——Y型电机 Motor size

| 泵型号 Type | 电机Motor | | b2 | h4 | h6 | h7 | l3 | l4 | l5 | l6 | i | q | 电机重量 (kg) Motor W · T | 底座参考 重量(kg) Baseplate W · T | 地脚螺栓 anchor bolt | | |
|-------------|----------|-----------------|-----|-----|-----|------|------|-----|-----|-----|------|------|-----------------------------|-----------------------------------|---------------------|------|-----|
| | 型号 Type | 功率Power (kW) | | | | | | | | | | | | | | | |
| 250-600 | 315L | 200 | 700 | 480 | 830 | 1380 | 2030 | 915 | - | 210 | 1340 | 1240 | 410 | 6-M24×500 | | | |
| | 355(6KV) | 220-315 | | | | | | | | | | | | | 1820 | 2160 | 440 |
| | 400(6KV) | 355-560 | | | | | | | | | | | | | 710 | 510 | 860 |
| 250-710 | 400(6KV) | 400-560 | 950 | 550 | 950 | 1385 | 2780 | 860 | 860 | 210 | 1940 | 2620 | 480 | 8-M30×600 | | | |
| | 450(6KV) | 630-800 | | | | | | | | | | | | | 1435 | 2900 | 900 |

DMC300-300 E Curve n=1450r/min

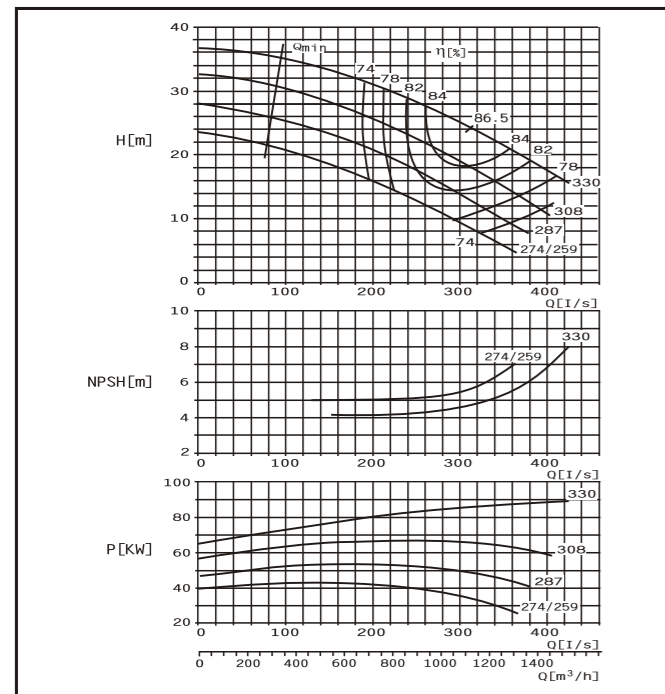

DMC300-300 F Curve n=1450r/min

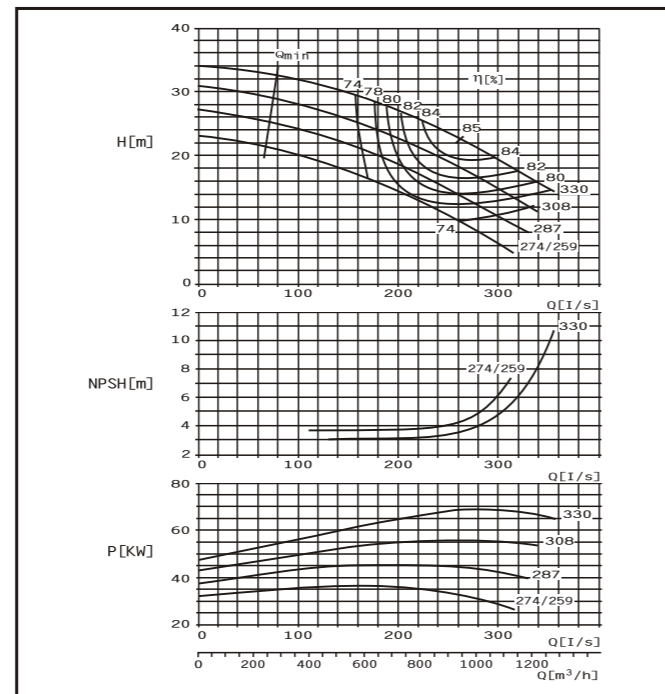

DMC300-435 E Curve n=1450r/min

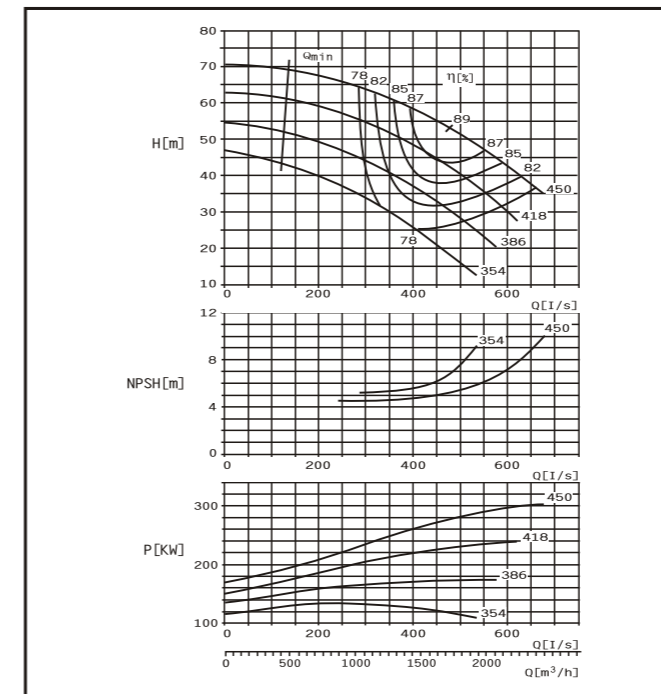

DMC300-435 F Curve n=1450r/min

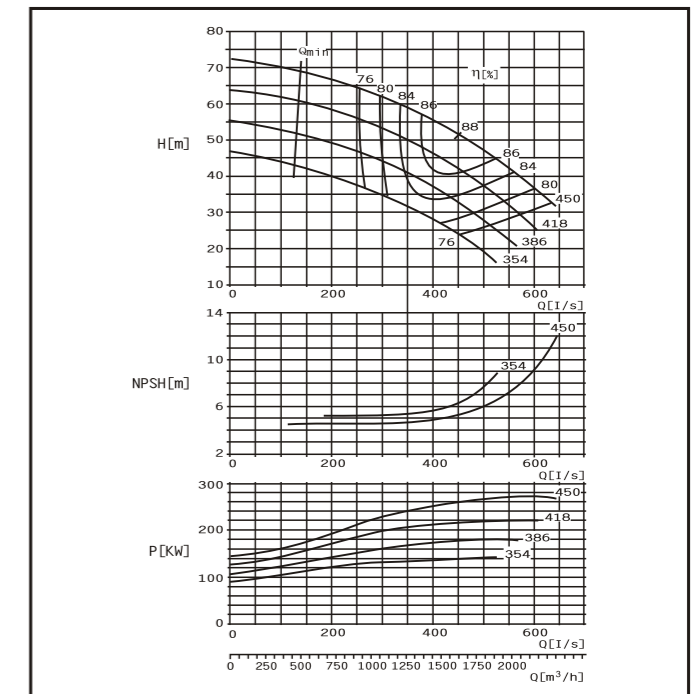

DMC卧式泵安装尺寸图 Installing dimensions of DMC pumps

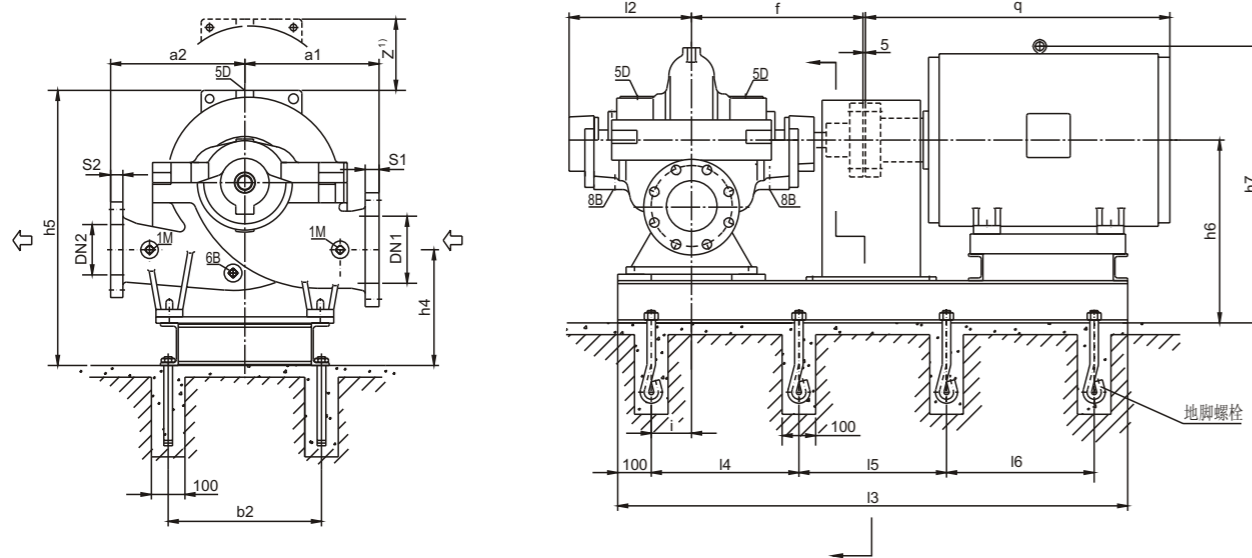

法兰钻孔示意图

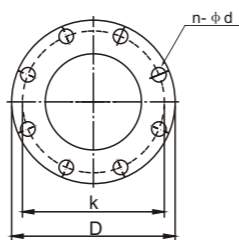

连接尺寸 connection dimensions:

- 1M 压力表 Rp1/2 1M pressure gauge Rp1/2
- 6B 排液孔 Rp1/2 6B drain plug Rp1/2
- 5D 排气孔 Rp1/2 5D air vent Rp1/2
- 8B 漏液排出孔 Rp3/4 8B drain plug Rp3/4

Z¹⁾ 拆卸转子所需最小空间尺寸

Z¹⁾ Min.dimensions of disassembling rotor assembly

参数表 Standard performance

| 泵型号 Type | 流量 Capacity Q | | 扬程 Head m | 转速 Speed r/min | 轴功率 Shaft power kW | 效率 eff % | 有效汽 蚀余量 NPSHa m | 电机功率 Motor power kW | 叶轮参 考直径 D(mm) |
|-----------------|---------------------|------|-----------------|----------------------|-----------------------------|----------------|--------------------------|------------------------------|---------------------|
| | m³/h | l/s | | | | | | | |
| DMC 300-300E | 878 | 244 | 28.8 | 1450 | 83.8 | 82.3 | 5.3 | 110 | 330 |
| | 1098 | 305 | 24.5 | | 85.2 | 86.5 | | | |
| | 1318 | 366 | 20 | | 89.4 | 80.3 | | | |
| | 835 | 232 | 23.5 | | 66.4 | 80.5 | | | |
| | 1044 | 290 | 19.8 | | 66.6 | 84.5 | | | |
| | 1253 | 348 | 15 | | 63.2 | 81 | | | |
| | 806 | 224 | 19 | | 52.8 | 79 | | | |
| | 1008 | 280 | 15.5 | | 51.9 | 82 | | | |
| | 1210 | 336 | 11.4 | | 48.2 | 78 | | | |
| | 772 | 214 | 15 | | 41.5 | 76 | | | |
| DMC 300-300F | 965 | 268 | 11.5 | 1450 | 37.8 | 80 | 6.0 | 45 | 274 |
| | 1158 | 322 | 7.5 | | 32 | 74 | | | |
| | 745 | 208 | 26.2 | | 64.4 | 83 | | | |
| | 936 | 260 | 23 | | 69 | 85 | | | |
| | 1123 | 312 | 20 | | 72.9 | 84 | | | |
| | 691 | 192 | 24.0 | | 56.2 | 80.5 | | | |
| | 864 | 240 | 20 | | 56 | 84 | | | |
| | 1037 | 288 | 15.8 | | 55.1 | 81 | | | |
| | 639 | 178 | 20 | | 45.5 | 76.5 | | | |
| | 800 | 222 | 16.7 | | 44.9 | 81 | | | |
| 960 | 267 | 13.5 | 44.6 | 79 | | | | | |
| 560 | 156 | 17.5 | 37.1 | 72 | | | | | |
| 700 | 194 | 15 | 37 | 77 | | | | | |
| 840 | 233 | 12 | 36.1 | 76 | | | | | |

参数表 Standard performance

| 泵型号 Type | 流量 Capacity Q | | 扬程 Head m | 转速 Speed r/min | 轴功率 Shaft power kW | 效率 eff % | 有效汽 蚀余量 NPSHa m | 电机功率 Motor power kW | 叶轮参 考直径 D(mm) |
|-----------------|---------------------|------|-----------------|----------------------|-----------------------------|----------------|--------------------------|------------------------------|---------------------|
| | m³/h | l/s | | | | | | | |
| DMC 300-435E | 1342 | 373 | 60 | 1450 | 257 | 85.5 | 7.1 | 315 | 450 |
| | 1677 | 466 | 53 | | 275 | 89 | | | |
| | 2012 | 559 | 46 | | 295 | 85.5 | | | |
| | 1262 | 350 | 52 | | 213 | 84 | | | |
| | 1577 | 438 | 45 | | 223 | 86.5 | | | |
| | 1892 | 526 | 37.5 | | 230 | 84 | | | |
| | 1181 | 328 | 42.5 | | 171 | 80 | | | |
| | 1476 | 410 | 36.5 | | 175 | 84 | | | |
| | 1771 | 492 | 28.5 | | 172 | 80 | | | |
| | 1088 | 302 | 33.8 | | 132 | 76 | | | |
| DMC 300-435F | 1360 | 378 | 27.5 | 1450 | 129 | 79 | 7.4 | 160 | 354 |
| | 1530 | 425 | 24 | | 128 | 78 | | | |
| | 1996 | 560 | 57.5 | | 240 | 84.8 | | | |
| | 1620 | 450 | 51.5 | | 260 | 88 | | | |
| | 1944 | 540 | 43.5 | | 273 | 84.5 | | | |
| | 1215 | 338 | 51.5 | | 206 | 83 | | | |
| | 1519 | 422 | 45 | | 215 | 86.5 | | | |
| | 1823 | 506 | 37.5 | | 222 | 84 | | | |
| | 1138 | 316 | 43.5 | | 168 | 80.5 | | | |
| | 1422 | 395 | 37.5 | | 173 | 84 | | | |
| 1706 | 474 | 30 | 174 | 80 | | | | | |
| 1066 | 296 | 35 | 130 | 78 | | | | | |
| 1361 | 370 | 30.5 | 136 | 81.5 | | | | | |
| 1598 | 444 | 24.5 | 138 | 77.5 | | | | | |

主要外型尺寸 pump outline size

| 泵型号 type | 法兰尺寸 flange size | | | | | | | | | | 泵尺寸 pump size | | | | | 泵重量W.T | | |
|-------------|-------------------|----|-----|-----|--------|--------------------|----|-----|-----|--------|---------------|-----|-----|------|-----|-----------------|-------|-------|
| | 进口法兰 inlet flange | | | | | 出口法兰 outlet flange | | | | | a1 | a2 | f | h5≤ | 12 | z ¹⁾ | 净重N.T | 湿重G.T |
| | DN1 | S1 | K | D | n-φd | DN2 | S2 | K | D | n-φd | | | | | | | | |
| 300-300 | 350 | 38 | 460 | 525 | 16-φ22 | 300 | 36 | 400 | 465 | 12-φ22 | 550 | 500 | 655 | 1430 | 464 | 726 | 630 | 730 |
| 300-435 | 400 | 40 | 515 | 585 | 16-φ26 | 300 | 36 | 400 | 465 | 12-φ22 | 650 | 550 | 730 | 1430 | 515 | 730 | 905 | 1095 |

电机尺寸——Y型电机 Motor size

| 泵型号 Type | 电机Motor | | b2 | h4 | h6 | h7 | l3 | l4 | l5 | l6 | i | q | 电机重量 (kg) Motor W · T | 底座参考 重量(kg) Baseplate W · T | 地脚螺栓 anchor bolt |
|-------------|------------|-----------------|-----|-----|-----|------|------|-----|----|-----|------|------|-----------------------------|-----------------------------------|---------------------|
| | 型号 Type | 功率Power (kW) | | | | | | | | | | | | | |
| 300-300 | 225M | 45 | 700 | 510 | 810 | 1115 | 1560 | 680 | - | 150 | 845 | 320 | 190 | 250 | 6-M24×500 |
| | 250M | 55 | | | | 1135 | 1620 | 710 | | | | | | | |
| | 280S | 75 | | | | 1170 | 1690 | 745 | | | | | | | |
| | 280M | 90 | | | | 1750 | 775 | | | | | | | | |
| | 315S | 110 | | | | 1360 | 1810 | 805 | | | | | | | |
| 300-435 | 315L | 160/200 | 700 | 520 | 870 | 1420 | 2030 | 915 | - | 210 | 1340 | 1240 | 410 | 410 | 8-M24×500 |
| | 355(6KV) | 220-315 | | | | 1295 | 2740 | 790 | | | | | | | |

DMC300-560 E Curve n=1450r/min

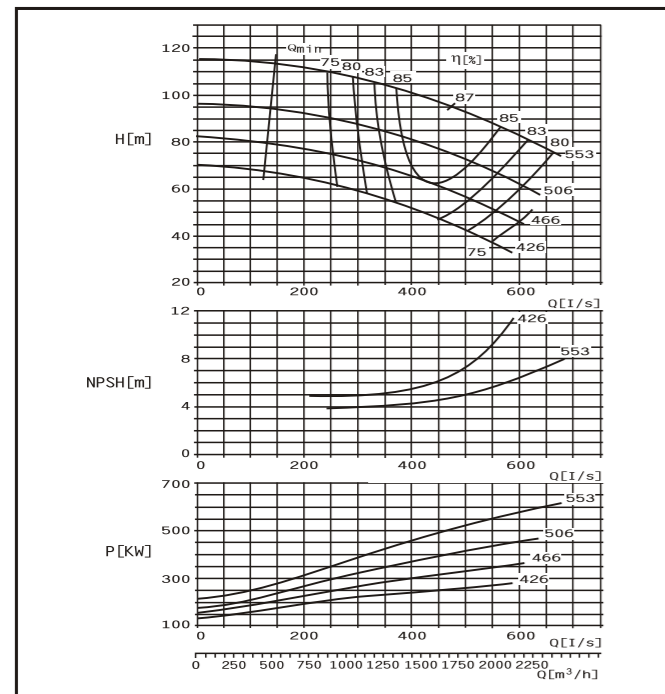

DMC300-560 F Curve n=1450r/min

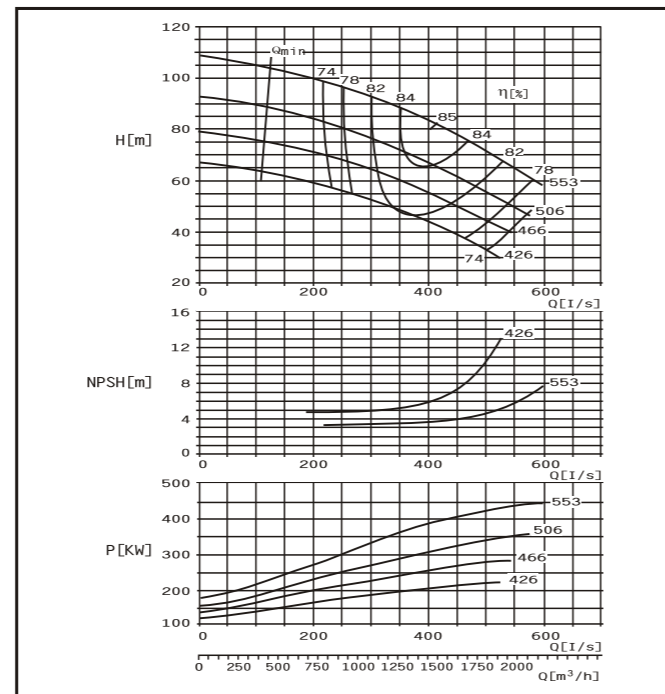

DMC卧式泵安装尺寸图 Installing dimensions of DMC pumps

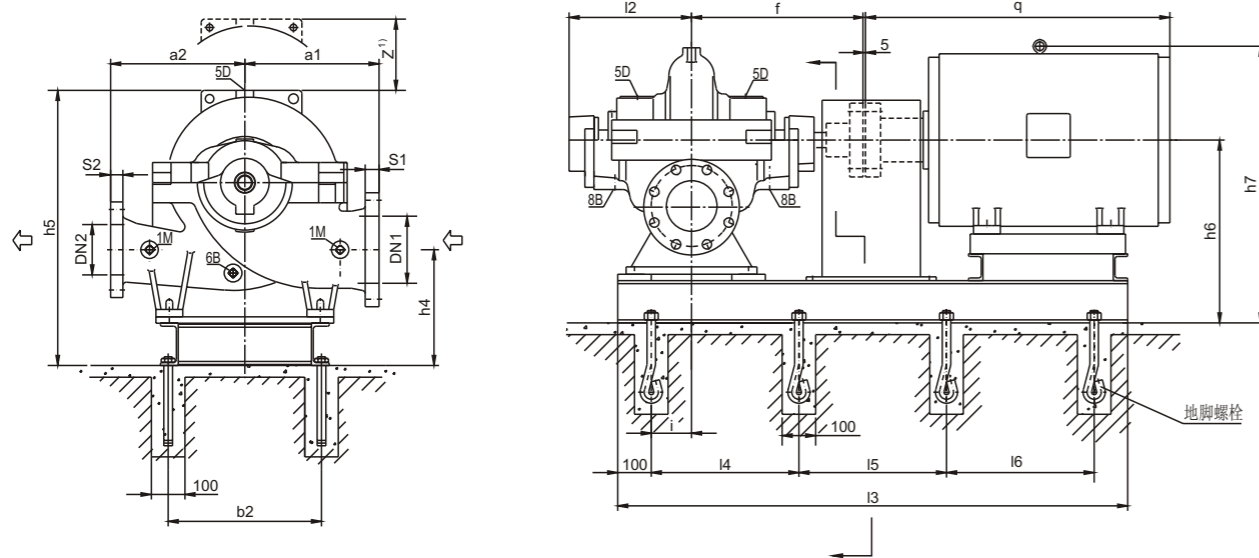

法兰钻孔示意图

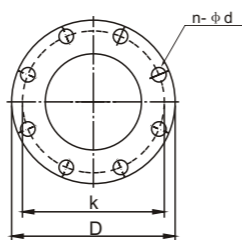

连接尺寸 connection dimensions:

- 1M 压力表 Rp1/2 1M pressure gauge Rp1/2
- 6B 排液孔 Rp1/2 6B drain plug Rp1/2
- 5D 排气孔 Rp1/2 5D air vent Rp1/2
- 8B 漏液排出孔 Rp3/4 8B drain plug Rp3/4

Z¹ 拆卸转子所需最小空间尺寸

Z¹ Min.dimensions of disassembling rotor assembly

DMC300-700 E Curve n=1450r/min

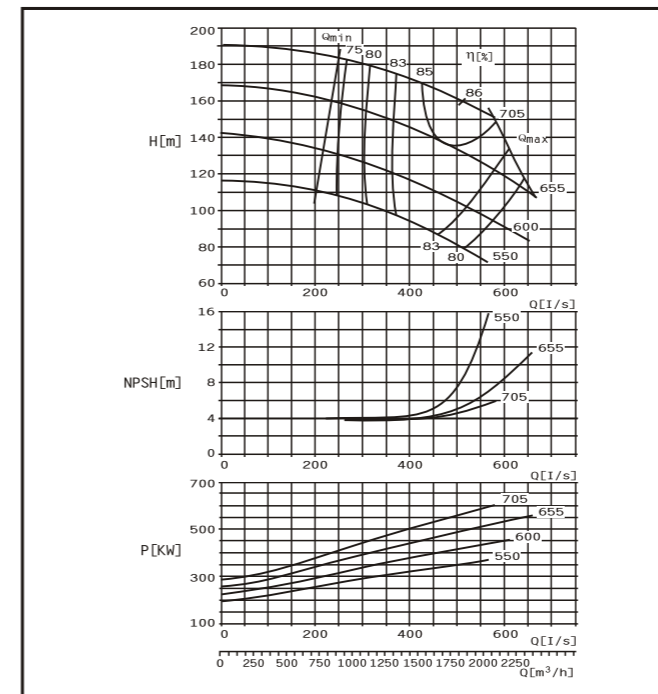

DMC300-700 F Curve n=1450r/min

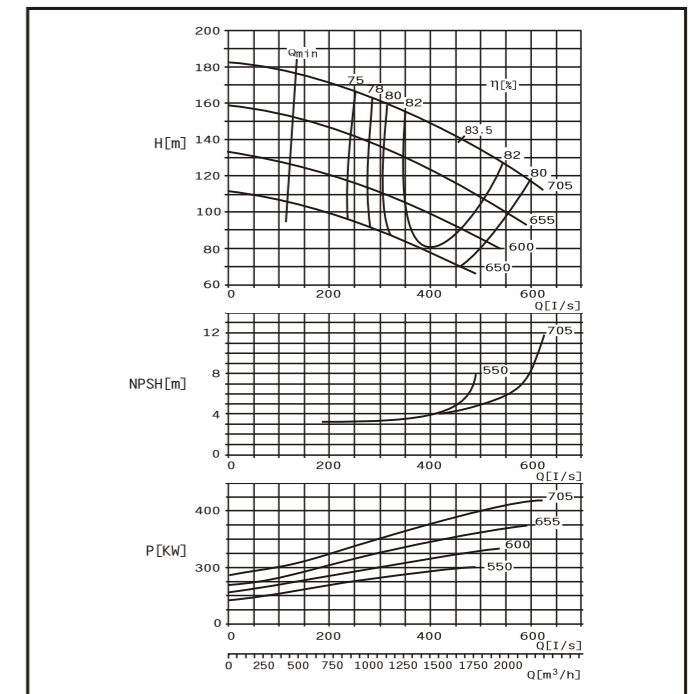

参数表 Standard performance

| 泵型号 Type | 流量 Capacity Q | | 扬程 Head m | 转速 Speed r/min | 轴功率 Shaft power kW | 效率 eff % | 有效汽 蚀余量 NPSHa m | 电机功率 Motor power kW | 叶轮参 考直径 D(mm) | | | | |
|-----------------|---------------------|-----|-----------------|----------------------|-----------------------------|----------------|--------------------------|------------------------------|---------------------|------|-----|-----|-----|
| | m³/h | l/s | | | | | | | | | | | |
| DMC 300-560E | 1397 | 388 | 101.5 | 1450 | 454 | 85.2 | 5.7 | 630 | 553 | | | | |
| | 1746 | 485 | 94 | | | | | | | | | | |
| | 2095 | 582 | 83.5 | | | | | | | | | | |
| | 1316 | 366 | 83.5 | | 357 | 83.8 | | | | 6.4 | 450 | 506 | |
| | 1645 | 457 | 76 | | 389 | 85.5 | | | | 6.7 | 355 | 466 | |
| | 1974 | 548 | 67 | | 433 | 83.3 | | | | 7.2 | 280 | 426 | |
| DMC 300-560F | 1258 | 350 | 68 | 1450 | 281 | 83 | 7.2 | 280 | 426 | | | | |
| | 1573 | 437 | 62 | | 313 | 85 | | | | 6.7 | 355 | 466 | |
| | 1888 | 524 | 54 | | 339 | 82 | | | | 7.2 | 280 | 426 | |
| | 1213 | 337 | 57 | | 232 | 81.2 | | | | 5.15 | 450 | 553 | |
| | 1516 | 421 | 50 | | 247 | 83.5 | | | | 5.55 | 355 | 506 | |
| | 1819 | 505 | 42 | | 260 | 80 | | | | 6.15 | 280 | 466 | |
| DMC 300-700E | 1469 | 408 | 170 | 1450 | 810 | 84 | 4.95 | 1120 | 705 | | | | |
| | 1836 | 510 | 160 | | 941 | 86 | | | | 5.0 | 800 | 550 | |
| | 2070 | 575 | 151 | | 1011 | 84.2 | | | | 4.85 | 710 | 655 | |
| | 1388 | 386 | 147 | | 662 | 84 | | | | 4.95 | 900 | 655 | |
| | 1735 | 482 | 136 | | 760 | 84.6 | | | | 5.0 | 710 | 600 | |
| | 2082 | 578 | 125 | | 854 | 83 | | | | 5.0 | 800 | 550 | |
| DMC 300-700F | 1298 | 361 | 122 | 1450 | 521 | 82.8 | 5.0 | 800 | 900 | | | | |
| | 1623 | 451 | 112 | | 587 | 84.3 | | | | 4.85 | 710 | 655 | |
| | 1948 | 541 | 100 | | 647 | 82 | | | | 4.85 | 600 | 550 | |
| | 1350 | 375 | 152 | | 679 | 82.3 | | | | 5.15 | 500 | 560 | 705 |
| | 1688 | 469 | 139 | | 765 | 83.5 | | | | 5.15 | 500 | 560 | 705 |
| | 2026 | 563 | 124 | | 840 | 81.5 | | | | 4.85 | 710 | 655 | |

参数表 Standard performance

| 泵型号 Type | 流量 Capacity Q | | 扬程 Head m | 转速 Speed r/min | 轴功率 Shaft power kW | 效率 eff % | 有效汽 蚀余量 NPSHa m | 电机功率 Motor power kW | 叶轮参 考直径 D(mm) | | | | |
|-----------------|---------------------|-----|-----------------|----------------------|-----------------------------|----------------|--------------------------|------------------------------|---------------------|------|-----|-----|-----|
| | m³/h | l/s | | | | | | | | | | | |
| DMC 300-560E | 1397 | 388 | 101.5 | 1450 | 454 | 85.2 | 5.7 | 630 | 553 | | | | |
| | 1746 | 485 | 94 | | | | | | | | | | |
| | 2095 | 582 | 83.5 | | | | | | | | | | |
| | 1316 | 366 | 83.5 | | 357 | 83.8 | | | | 6.4 | 450 | 506 | |
| | 1645 | 457 | 76 | | 389 | 85.5 | | | | 6.7 | 355 | 466 | |
| | 1974 | 548 | 67 | | 433 | 83.3 | | | | 7.2 | 280 | 426 | |
| DMC 300-560F | 1258 | 350 | 68 | 1450 | 281 | 83 | 7.2 | 280 | 426 | | | | |
| | 1573 | 437 | 62 | | 313 | 85 | | | | 6.7 | 355 | 466 | |
| | 1888 | 524 | 54 | | 339 | 82 | | | | 7.2 | 280 | 426 | |
| | 1213 | 337 | 57 | | 232 | 81.2 | | | | 5.15 | 450 | 553 | |
| | 1516 | 421 | 50 | | 247 | 83.5 | | | | 5.55 | 355 | 506 | |
| | 1819 | 505 | 42 | | 260 | 80 | | | | 6.15 | 280 | 466 | |
| DMC 300-700E | 1469 | 408 | 170 | 1450 | 810 | 84 | 4.95 | 1120 | 705 | | | | |
| | 1836 | 510 | 160 | | 941 | 86 | | | | 5.0 | 800 | 550 | |
| | 2070 | 575 | 151 | | 1011 | 84.2 | | | | 4.85 | 710 | 655 | |
| | 1388 | 386 | 147 | | 662 | 84 | | | | 4.95 | 900 | 655 | |
| | 1735 | 482 | 136 | | 760 | 84.6 | | | | 5.0 | 710 | 600 | |
| | 2082 | 578 | 125 | | 854 | 83 | | | | 5.0 | 800 | 550 | |
| DMC 300-700F | 1298 | 361 | 122 | 1450 | 521 | 82.8 | 5.0 | 800 | 900 | | | | |
| | 1623 | 451 | 112 | | 587 | 84.3 | | | | 4.85 | 710 | 655 | |
| | 1948 | 541 | 100 | | 647 | 82 | | | | 4.85 | 600 | 550 | |
| | 1350 | 375 | 152 | | 679 | 82.3 | | | | 5.15 | 500 | 560 | 705 |
| | 1688 | 469 | 139 | | 765 | 83.5 | | | | 5.15 | 500 | 560 | 705 |
| | 2026 | 563 | 124 | | 840 | 81.5 | | | | 4.85 | 710 | 655 | |

主要外型尺寸 pump outline size

| 泵型号 type | 法兰尺寸 flange size | | | | | | | | | | 泵尺寸 pump size | | | | | 泵重量W.T | | |
|-------------|-------------------|----|-----|-----|--------|--------------------|----|-----|-----|--------|---------------|-----|-----|------|-----|----------------|-------|-------|
| | 进口法兰 inlet flange | | | | | 出口法兰 outlet flange | | | | | a1 | a2 | f | h5≤ | 12 | z ¹ | 净重N.T | 湿重G.T |
| | DN1 | S1 | K | D | n-φd | DN2 | S2 | K | D | n-φd | | | | | | | | |
| 300-560 | 400 | 40 | 525 | 585 | 16-φ30 | 300 | 36 | 410 | 465 | 12-φ25 | 700 | 650 | 810 | 1430 | 585 | 860 | 1425 | 1650 |
| 300-700 | 400 | 48 | 550 | 610 | 16-φ34 | 300 | 42 | 430 | 490 | 16-φ30 | 750 | 650 | 810 | 1430 | 585 | 960 | 1690 | 1965 |

电机尺寸——Y型电机 Motor size

| 泵型号 Type | 电机Motor | | b2 | h4 | h6 | h7 | l3 | l4 | l5 | l6 | i | q | 电机重量 (kg) Motor W · T | 底座参考 重量(kg) Baseplate W · T | 地脚螺栓 anchor bolt |
|-------------|------------|-----------------|-----|-----|-----|------|------|-----|-----|-----|------|------|-----------------------------|-----------------------------------|---------------------|
| | 型号 Type | 功率Power (kW) | | | | | | | | | | | | | |
| 300-560 | 355(6KV) | 220-315 | 950 | 560 | 910 | 1335 | 2815 | 820 | 820 | 210 | 1820 | 2160 | 440 | 8- M30×600 | |
| | 400(6KV) | 355-560 | | | | | | | | | | | | | |
| | 450(6KV) | 630 | | | | | | | | | | | | | |
| 300-700 | 400(6KV) | 400-560 | 950 | 550 | 950 | 1385 | 2930 | 860 | 860 | 210 | 1940 | 2620 | 480 | 8- M30×600 | |
| | 450(6KV) | 630-900 | | | | | | | | | | | | | |
| | 500(6KV) | 1000/1120 | | | | | | | | | | | | | |

DMC350-360 E Curve n=1450r/min

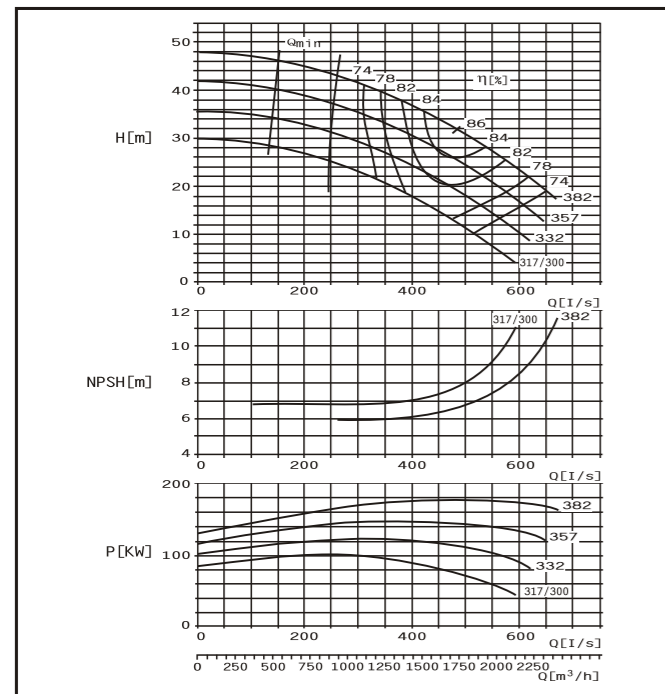

DMC350-360 F Curve n=1450r/min

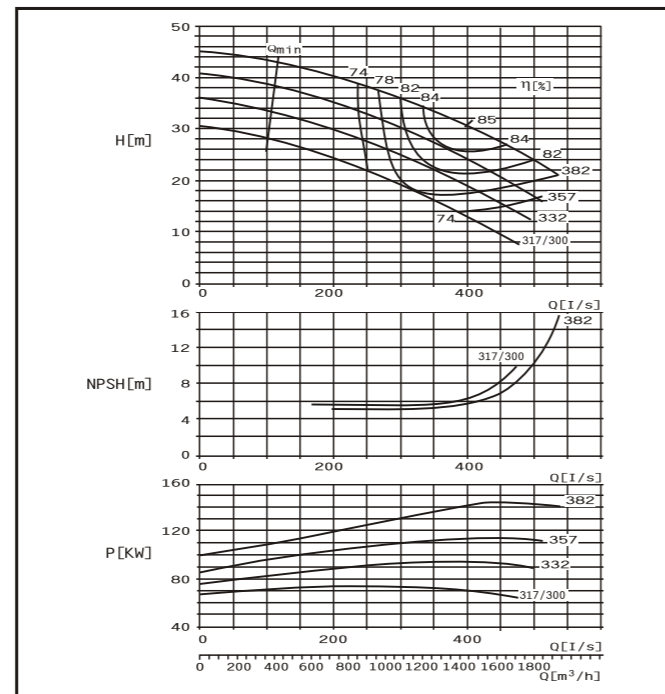

DMC卧式泵安装尺寸图 Installing dimensions of DMC pumps

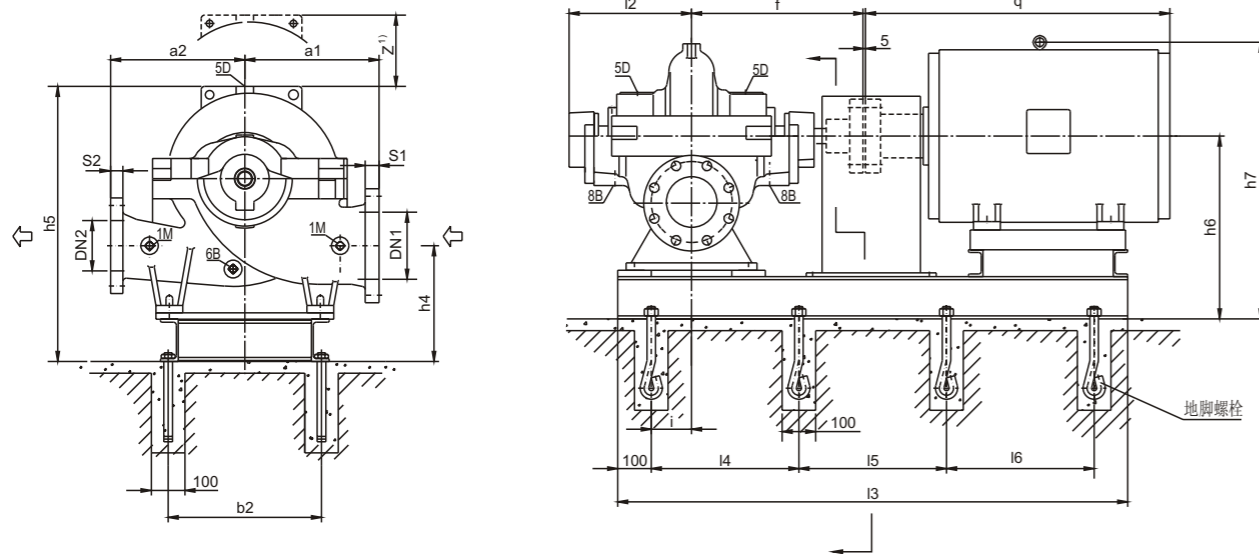

连接尺寸 connection dimensions:

- 1M 压力表 Rp1/2 1M pressure gauge Rp1/2
- 6B 排液孔 Rp1/2 6B drain plug Rp1/2
- 5D 排气孔 Rp1/2 5D air vent Rp1/2
- 8B 漏液排出孔 Rp3/4 8B drain plug Rp3/4

Z¹ 拆卸转子所需最小空间尺寸

Z¹ Min.dimensions of disassembling rotor assembly

法兰钻孔示意图

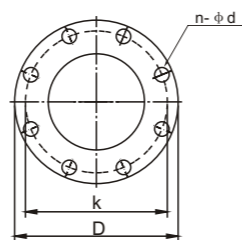

DMC350-430 E Curve n=1450r/min

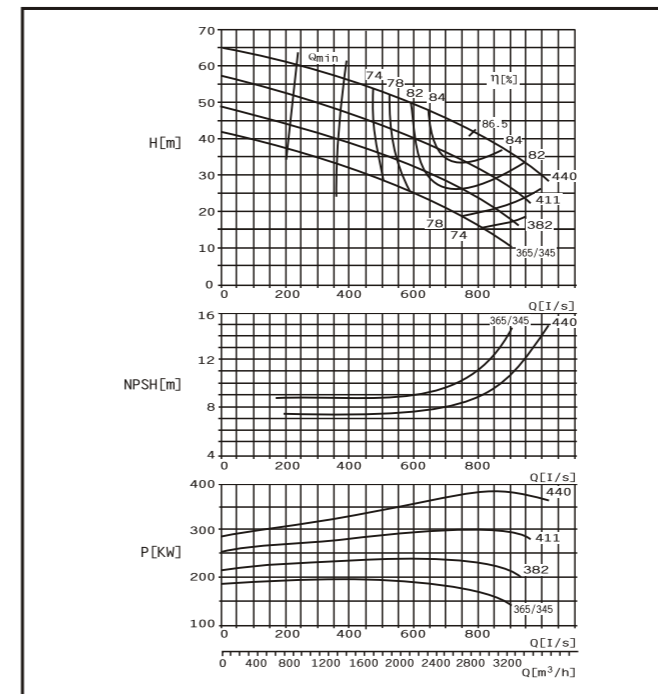

DMC350-430 F Curve n=1450r/min

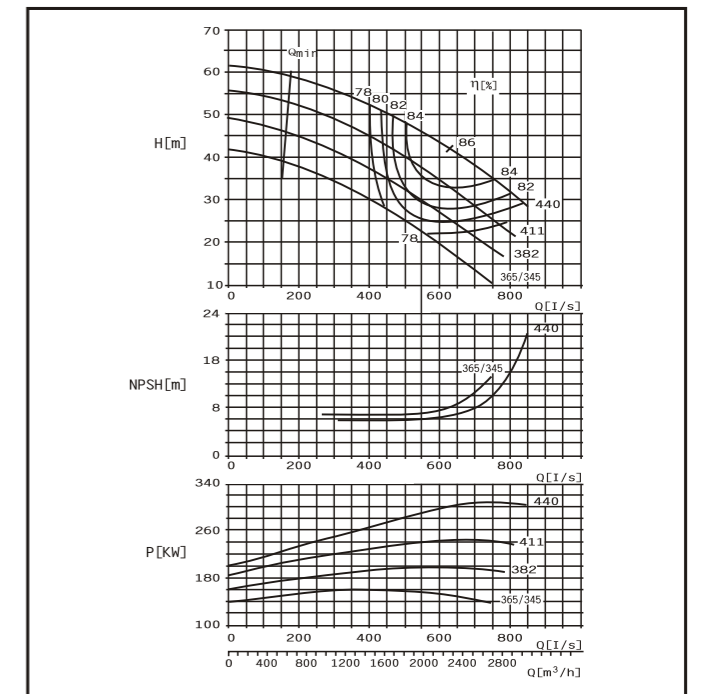

参数表 Standard performance

| 泵型号 Type | 流量 Capacity Q | | 扬程 Head m | 转速 Speed r/min | 轴功率 Shaft power kW | 效率 eff η % | 有效汽 蚀余量 NPSHa m | 电机功率 Motor power kW | 叶轮参 考直径 D(mm) |
|-----------------|---------------------|-----|-----------------|----------------------|-----------------------------|------------------|--------------------------|------------------------------|---------------------|
| | m³/h | l/s | | | | | | | |
| DMC 350-360E | 1385 | 385 | 37.5 | 1450 | 171 | 83 | 8.1 | 200 | 382 |
| | 1731 | 481 | 32 | | 175 | 86.5 | | | |
| | 2077 | 577 | 25 | | 146 | 81 | | | |
| | 1354 | 376 | 32 | | 144 | 85 | | | |
| | 1692 | 470 | 26.5 | | 138 | 80 | | | |
| | 2030 | 564 | 20 | | 120 | 78.8 | | | |
| DMC 350-360F | 1313 | 365 | 26.5 | 1450 | 113 | 83 | 8.7 | 132 | 332 |
| | 1641 | 456 | 21 | | 103 | 78 | | | |
| | 1989 | 547 | 15 | | 91 | 76.3 | | | |
| | 1282 | 356 | 20 | | 81 | 80.5 | | | |
| | 1602 | 445 | 15 | | 64 | 74 | | | |
| | 1922 | 534 | 9 | | 133 | 83 | | | |
| DMC 350-430E | 1422 | 395 | 31 | 1450 | 140 | 85.5 | 8.4 | 160 | 357 |
| | 1706 | 474 | 25.8 | | 144 | 83.3 | | | |
| | 1068 | 297 | 30.5 | | 110 | 81 | | | |
| | 1335 | 371 | 26.3 | | 114 | 84 | | | |
| | 1602 | 445 | 21.3 | | 103 | 81 | | | |
| | 1016 | 282 | 25.6 | | 90 | 79 | | | |
| DMC 350-430F | 1270 | 353 | 22.5 | 1450 | 95 | 82 | 6.7 | 110 | 332 |
| | 1524 | 423 | 17.5 | | 93 | 78 | | | |
| | 350 | 264 | 21.5 | | 74 | 75.5 | | | |
| | 1188 | 330 | 17.8 | | 74 | 78 | | | |
| | 1397 | 388 | 13.7 | | 71 | 74 | | | |
| | 1786 | 496 | 48 | | 277 | 84.2 | | | |
| DMC 350-430E | 2194 | 610 | 49.5 | 1450 | 371 | 84.7 | 12.2 | 400 | 440 |
| | 2743 | 762 | 43.5 | | 291 | 82 | | | |
| | 3292 | 914 | 35 | | 281 | 85.5 | | | |
| | 2108 | 586 | 32 | | 291 | 82 | | | |
| | 2635 | 732 | 35 | | 294 | 85.5 | | | |
| | 3162 | 878 | 27 | | 281 | 82.8 | | | |
| DMC 350-430F | 2050 | 570 | 33 | 1450 | 231 | 80 | 13.1 | 250 | 382 |
| | 2563 | 712 | 27.5 | | 229 | 84 | | | |
| | 3076 | 854 | 20 | | 210 | 80 | | | |
| | 1987 | 552 | 27 | | 187 | 78 | | | |
| | 2484 | 690 | 21.5 | | 180 | 81 | | | |
| | 2981 | 828 | 15 | | 160 | 76.3 | | | |
| DMC 350-430E | 1786 | 496 | 48 | 1450 | 277 | 84.2 | 9.0 | 315 | 440 |
| | 2232 | 620 | 42.5 | | 303 | 84.2 | | | |
| | 1670 | 464 | 42.5 | | 237 | 81.5 | | | |
| | 2088 | 580 | 36 | | 242 | 84.5 | | | |
| | 2506 | 696 | 28.8 | | 240 | 82 | | | |
| | 1590 | 442 | 35 | | 193 | 78.5 | | | |
| DMC 350-430F | 1987 | 552 | 30 | 1450 | 198 | 82 | 9.9 | 220 | 382 |
| | 2384 | 662 | 23.5 | | 195 | 78.2 | | | |
| | 350 | 264 | 21.5 | | 160 | 76 | | | |
| | 1486 | 413 | 30 | | 161 | 78.5 | | | |
| | 1858 | 516 | 25 | | 148 | 76 | | | |
| | 2230 | 619 | 18.5 | | 148 | 76 | | | |

参数表 Standard performance

| 泵型号 Type | 流量 Capacity Q | | 扬程 Head m | 转速 Speed r/min | 轴功率 Shaft power kW | 效率 eff η % | 有效汽 蚀余量 NPSHa m | 电机功率 Motor power kW | 叶轮参 考直径 D(mm) |
|-----------------|---------------------|-----|-----------------|----------------------|-----------------------------|------------------|--------------------------|------------------------------|---------------------|
| | m³/h | l/s | | | | | | | |
| DMC 350-360E | 1385 | 385 | 37.5 | 1450 | 171 | 83 | 8.1 | 200 | 382 |
| | 1731 | 481 | 32 | | 175 | 86.5 | | | |
| | 2077 | 577 | 25 | | 146 | 81 | | | |
| | 1354 | 376 | 32 | | 144 | 85 | | | |
| | 1692 | 470 | 26.5 | | 138 | 80 | | | |
| | 2030 | 564 | 20 | | 120 | 78.8 | | | |
| DMC 350-360F | 1313 | 365 | 26.5 | 1450 | 113 | 83 | 8.7 | 132 | 332 |
| | 1641 | 456 | 21 | | 103 | 78 | | | |
| | 1989 | 547 | 15 | | 91 | 76.3 | | | |
| | 1282 | 356 | 20 | | 81 | 80.5 | | | |
| | 1602 | 445 | 15 | | 64 | 74 | | | |
| | 1922 | 534 | 9 | | 133 | 83 | | | |
| DMC 350-430E | 1422 | 395 | 31 | 1450 | 140 | 85.5 | 8.4 | 160 | 357 |
| | 1706 | 474 | 25.8 | | 144 | 83.3 | | | |
| | 1068 | 297 | 30.5 | | 110 | 81 | | | |
| | 1335 | 371 | 26.3 | | 114 | 84 | | | |
| | 1602 | 445 | 21.3 | | 103 | 81 | | | |
| | 1016 | 282 | 25.6 | | 90 | 79 | | | |
| DMC 350-430F | 1270 | 353 | 22.5 | 1450 | 95 | 82 | 6.7 | 110 | 332 |
| | 1524 | 423 | 17.5 | | 93 | 78 | | | |
| | 350 | 264 | 21.5 | | 74 | 75.5 | | | |
| | 1188 | 330 | 17.8 | | 74 | 78 | | | |
| | 1397 | 388 | 13.7 | | 71 | 74 | | | |
| | 1786 | 496 | 48 | | 277 | 84.2 | | | |
| DMC 350-430E | 2194 | 610 | 49.5 | 1450 | 371 | 84.7 | 12.2 | 400 | 440 |
| | 2743 | 762 | 43.5 | | 291 | 82 | | | |
| | 3292 | 914 | 35 | | 281 | 85.5 | | | |
| | 2108 | 586 | 32 | | 291 | 82 | | | |
| | 2635 | 732 | 35 | | 294 | 85.5 | | | |
| | 3162 | 878 | 27 | | 281 | 82.8 | | | |
| DMC 350-430F | 2050 | 570 | 33 | 1450 | 231 | 80 | 13.1 | 250 | 382 |
| | 2563 | 712 | 27.5 | | 229 | 84 | | | |
| | 3076 | 854 | 20 | | 210 | 80 | | | |
| | 1987 | 552 | 27 | | 187 | 78 | | | |
| | 2484 | 690 | 21.5 | | 180 | 81 | | | |
| | 2981 | 828 | 15 | | 160 | 76.3 | | | |
| DMC 350-430E | 1786 | 496 | 48 | 1450 | 277 | 84.2 | 9.0 | 315 | 440 |
| | 2232 | 620 | 42.5 | | 303 | 84.2 | | | |
| | 1670 | 464 | 42.5 | | 237 | 81.5 | | | |
| | 2088 | 580 | 36 | | 242 | 84.5 | | | |
| | 2506 | 696 | 28.8 | | 240 | 82 | | | |
| | 1590 | 442 | 35 | | 193 | 78.5 | | | |
| DMC 350-430F | 1987 | 552 | 30 | 1450 | 198 | 82 | 9.9 | 220 | 382 |
| | 2384 | 662 | 23.5 | | 195 | 78.2 | | | |
| | 350 | 264 | 21.5 | | 160 | 76 | | | |
| | 1486 | 413 | 30 | | 161 | 78.5 | | | |
| | 1858 | 516 | 25 | | 148 | 76 | | | |
| | 2230 | 619 | 18.5 | | 148 | 76 | | | |

主要外型尺寸 pump outline size

| 泵型号 type | 法兰尺寸 flange size | | | | | | | | | | 泵尺寸 pump size | | | | | 泵重量W.T | | |
|-------------|-------------------|----|-----|-----|--------|--------------------|----|-----|-----|--------|---------------|-----|-----|------|-----|----------------|-------|-------|
| | 进口法兰 inlet flange | | | | | 出口法兰 outlet flange | | | | | a1 | a2 | f | h5≤ | 12 | z ¹ | 净重N.T | 湿重G.T |
| | DN1 | S1 | K | D | n-φd | DN2 | S2 | K | D | n-φd | | | | | | | | |
| 350-360 | 400 | 40 | 515 | 585 | 16-φ26 | 350 | 38 | 460 | 525 | 16-φ22 | 650 | 550 | 730 | 1415 | 515 | 820 | 865 | 1025 |
| 350-430 | 450 | 44 | 565 | 645 | 20-φ26 | 350 | 38 | 460 | 525 | 16-φ22 | 750 | 650 | 810 | 1415 | 585 | 930 | 1285 | 1525 |

电机尺寸——Y型电机 Motor size

| 泵型号 Type | 电机Motor | | b2 | h4 | h6 | h7 | l3 | l4 | l5 | l6 | i | q | 电机重量 (kg) Motor W · T | 底座参考 重量(kg) Baseplate W · T | 地脚螺栓 anchor bolt |
|-------------|------------|-----------------|-----|-----|-----|------|------|-----|----|-----|------|------|-----------------------------|-----------------------------------|---------------------|
| | 型号 Type | 功率Power (kW) | | | | | | | | | | | | | |
| 350-360 | 280M | 90 | 700 | 520 | 870 | 1230 | 1880 | 840 | - | 210 | 1050 | 667 | 250 | 410 | 6-M24×500 |
| | 315S | 110 | | | | | | | | | | | | | |
| | 315M | 132 | | | | | | | | | | | | | |
| | 315L | 160/200 | | | | | | | | | | | | | |
| 350-430 | 315L | 200 | 950 | 550 | 950 | 1500 | 2110 | 955 | - | 210 | 1340 | 1240 | 410 | 410 | 6-M30×600 |
| | 355(6KV) | 220-315 | | | | | | | | | | | | | |
| | 400(6KV) | 355/400 | | | | | | | | | | | | | |
| | 355(6KV) | 355/400 | | | | | | | | | | | | | |

DMC350-510 E Curve n=1450r/min

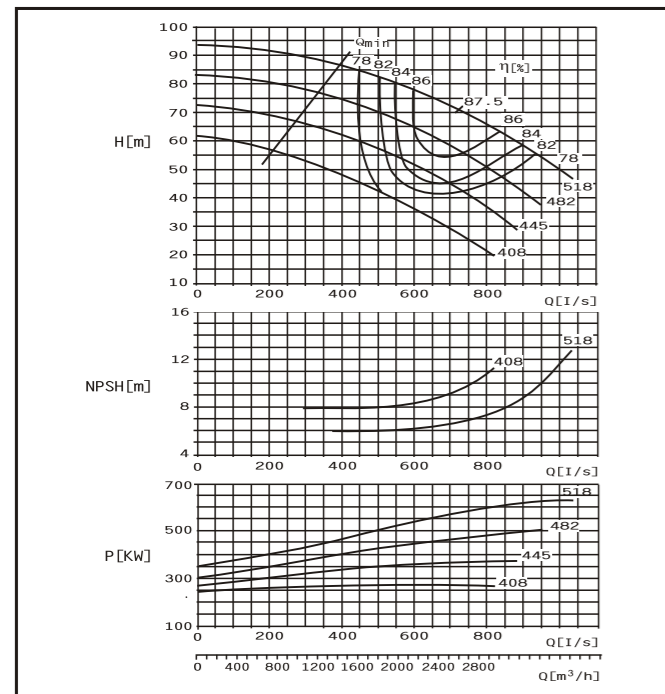

DMC350-510 F Curve n=1450r/min

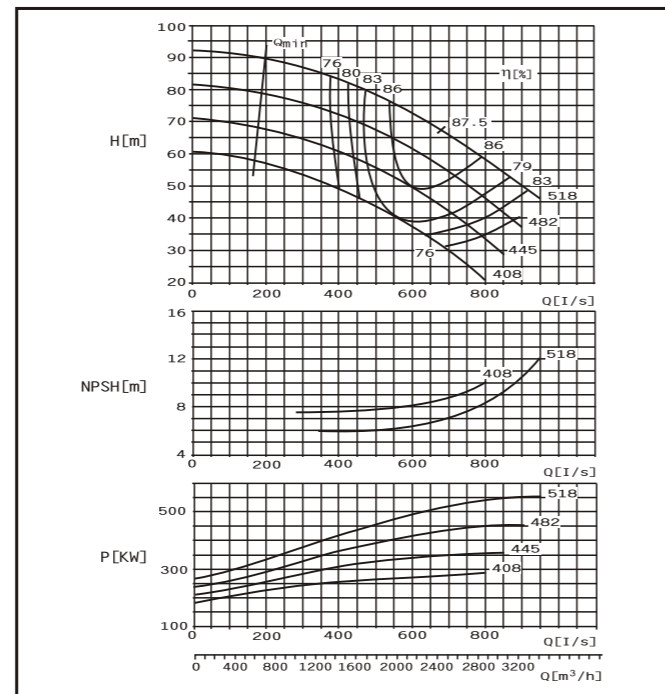

DMC卧式泵安装尺寸图 Installing dimensions of DMC pumps

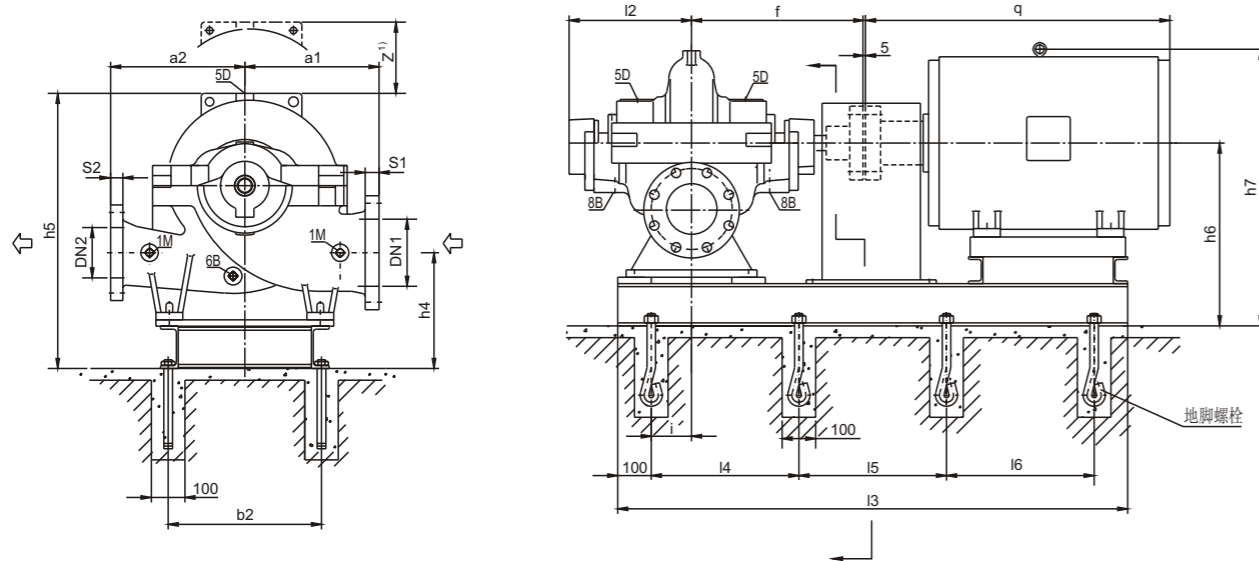

连接尺寸 connection dimensions:
 1M 压力表 Rp1/2 1M pressure gauge Rp1/2
 6B 排液孔 Rp1/2 6B drain plug Rp1/2
 5D 排气孔 Rp1/2 5D air vent Rp1/2
 8B 漏液排出孔 Rp3/4 8B drain plug Rp3/4
 Z¹ 拆卸转子所需最小空间尺寸
 Z¹ Min.dimensions of disassembling rotor assembly

法兰钻孔示意图

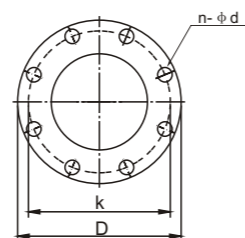

DMC350-590 E Curve n=1450r/min

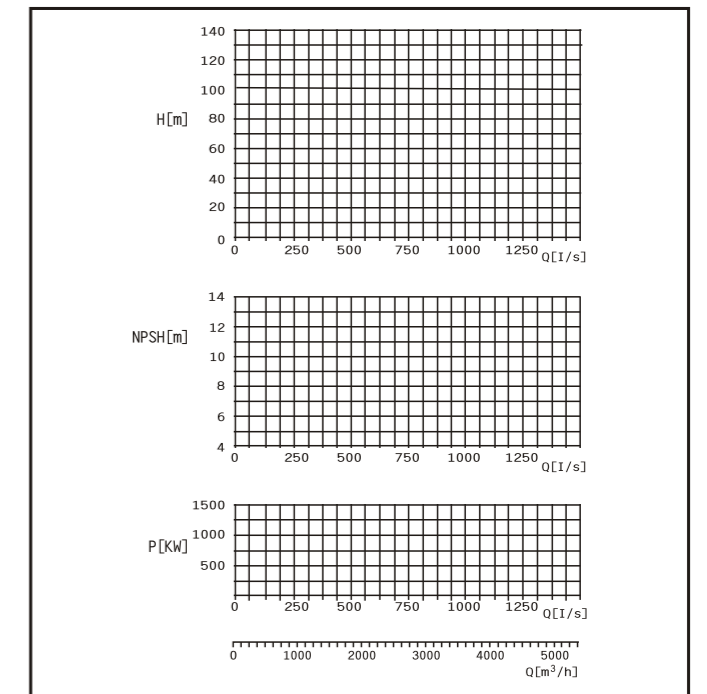
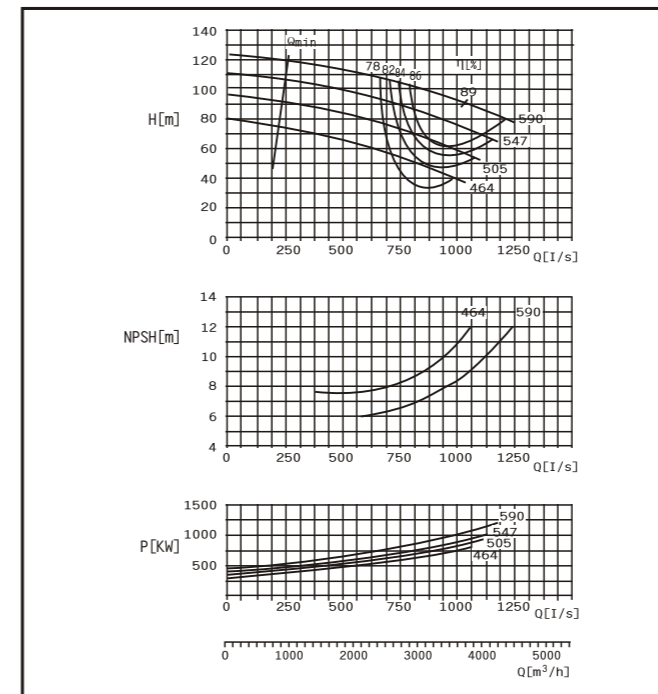

参数表 Standard performance

| 泵型号 Type | 流量 Capacity Q | | 扬程 Head m | 转速 Speed r/min | 轴功率 Shaft power kW | 效率 eff η % | 有效汽 蚀余量 NPSHa m | 电机功率 Motor power kW | 叶轮参 考直径 D(mm) |
|-----------------|---------------------|------|-----------------|----------------------|-----------------------------|------------------|--------------------------|------------------------------|---------------------|
| | m ³ /h | l/s | | | | | | | |
| DMC 350-510E | 2088 | 580 | 80 | 1450 | 529 | 86 | 10.0 | 630 | 518 |
| | 2610 | 725 | 70 | | 562 | 88.5 | | | |
| | 3132 | 870 | 60 | | 605 | 84.7 | | | |
| | 1944 | 540 | 68 | | 426 | 84.5 | | | |
| | 2430 | 675 | 60 | | 456 | 87 | | | |
| 2916 | 810 | 50 | 473 | 84 | | | | | |
| DMC 350-510F | 1786 | 496 | 57.5 | 1450 | 345 | 81 | 11.0 | 400 | 445 |
| | 2232 | 620 | 50 | | 353 | 86 | | | |
| | 2678 | 744 | 40 | | 360 | 81 | | | |
| | 1656 | 460 | 45 | | 267 | 76 | | | |
| | 2070 | 575 | 38 | | 271 | 79 | | | |
| 2484 | 690 | 30 | 264 | 77 | | | | | |
| DMC 350-510E | 1958 | 544 | 76 | 1450 | 466 | 87 | 9.9 | 560 | 518 |
| | 2448 | 680 | 67 | | 508 | 88 | | | |
| | 2938 | 816 | 57 | | 531 | 86 | | | |
| | 1814 | 504 | 67.5 | | 393 | 85 | | | |
| | 2268 | 630 | 59.5 | | 422 | 87 | | | |
| 2722 | 756 | 50 | 436 | 85 | | | | | |
| DMC 350-510F | 1670 | 464 | 58 | 1450 | 320 | 82.5 | 10.4 | 400 | 445 |
| | 2088 | 580 | 50 | | 335 | 85 | | | |
| | 2506 | 696 | 41.5 | | 344 | 82.5 | | | |
| | 1555 | 432 | 47.5 | | 258 | 78 | | | |
| | 1944 | 540 | 41.5 | | 265 | 83 | | | |
| 2333 | 648 | 34.5 | 274 | 80 | | | | | |

参数表 Standard performance

| 泵型号 Type | 流量 Capacity Q | | 扬程 Head m | 转速 Speed r/min | 轴功率 Shaft power kW | 效率 eff η % | 有效汽 蚀余量 NPSHa m | 电机功率 Motor power kW | 叶轮参 考直径 D(mm) |
|-----------------|---------------------|------|-----------------|----------------------|-----------------------------|------------------|--------------------------|------------------------------|---------------------|
| | m ³ /h | l/s | | | | | | | |
| DMC 350-590E | 3036 | 843 | 100 | 1450 | 956 | 86.5 | 9.9 | 1250 | 590 |
| | 3735 | 1054 | 90 | | 1046 | 89 | | | |
| | 4500 | 1250 | 78 | | 1139 | 84 | | | |
| | 2834 | 787 | 88 | | 800 | 85.1 | | | |
| | 3543 | 984 | 77.2 | | 857 | 87 | | | |
| 4162 | 1156 | 66 | 891 | 84 | | | | | |
| DMC 350-590E | 2604 | 723 | 74 | 1450 | 648 | 81 | 11 | 710 | 505 |
| | 3255 | 904 | 64.3 | | 663 | 86 | | | |
| | 3906 | 1085 | 53 | | 688 | 82 | | | |
| | 2556 | 710 | 56 | | 497 | 78.5 | | | |
| | 3020 | 839 | 48.9 | | 517 | 79 | | | |
| 3623 | 1006 | 40.6 | 517 | 77.5 | | | | | |

主要外型尺寸 pump outline size

| 泵型号 type | 法兰尺寸 flange size | | | | | | | | | 泵尺寸 pump size | | | | | 泵重量W.T | | | |
|-------------|-------------------|----|-----|-----|--------|--------------------|----|-----|-----|---------------|-----|-----|-----|------|----------------|-------|-------|------|
| | 进口法兰 inlet flange | | | | | 出口法兰 outlet flange | | | | a1 | a2 | f | h5≤ | 12 | z ¹ | 净重N.T | 湿重G.T | |
| | DN1 | S1 | K | D | n-φd | DN2 | S2 | K | D | | | | | | | | | n-φd |
| 350-510 | 400 | 40 | 615 | 585 | 16-φ26 | 350 | 38 | 460 | 525 | 16-φ22 | 700 | 650 | 810 | 1415 | 585 | 840 | 1395 | 1685 |
| 350-590 | 500 | 46 | 620 | 710 | 20-φ26 | 350 | 38 | 460 | 525 | 16-φ22 | 750 | 650 | 810 | 1415 | 585 | 960 | 1510 | 1800 |

电机尺寸——Y型电机 Motor size

| 泵型号 Type | 电机Motor | | b2 | h4 | h6 | h7 | l3 | l4 | l5 | l6 | i | q | 电机重量 (kg) Motor W · T | 底座参考 重量(kg) Baseplate W · T | 地脚螺栓 anchor bolt |
|-------------|------------|---------------------|-----|-----|-----|------|------|------|------|-----|------|------|-----------------------------|-----------------------------------|---------------------|
| | 型号 Type | 功率 Power (kW) | | | | | | | | | | | | | |
| 350-510 | 355(6KV) | 280/315 | 950 | 550 | 950 | 1375 | 2660 | 820 | 820 | 210 | 1820 | 2160 | 440 | 8- M30×600 | |
| | 400(6KV) | 355-560 | | | | 1385 | 2780 | 860 | 860 | | | | | | |
| | 450(6KV) | 630 | | | | 1435 | 2900 | 900 | 900 | | | | | | |
| 350-590 | 400(6KV) | 560 | 950 | 550 | 950 | 1385 | 2780 | 860 | 860 | 210 | 1940 | 2620 | 480 | 8- M30×600 | |
| | 450(6KV) | 630-900 | | | | 1435 | 2900 | 900 | 900 | | | | | | |
| | 500(6KV) | 1000-1250 | | | | 1490 | 3200 | 1000 | 1000 | | | | | | |

DMC350-620E Curve n=1450r/min

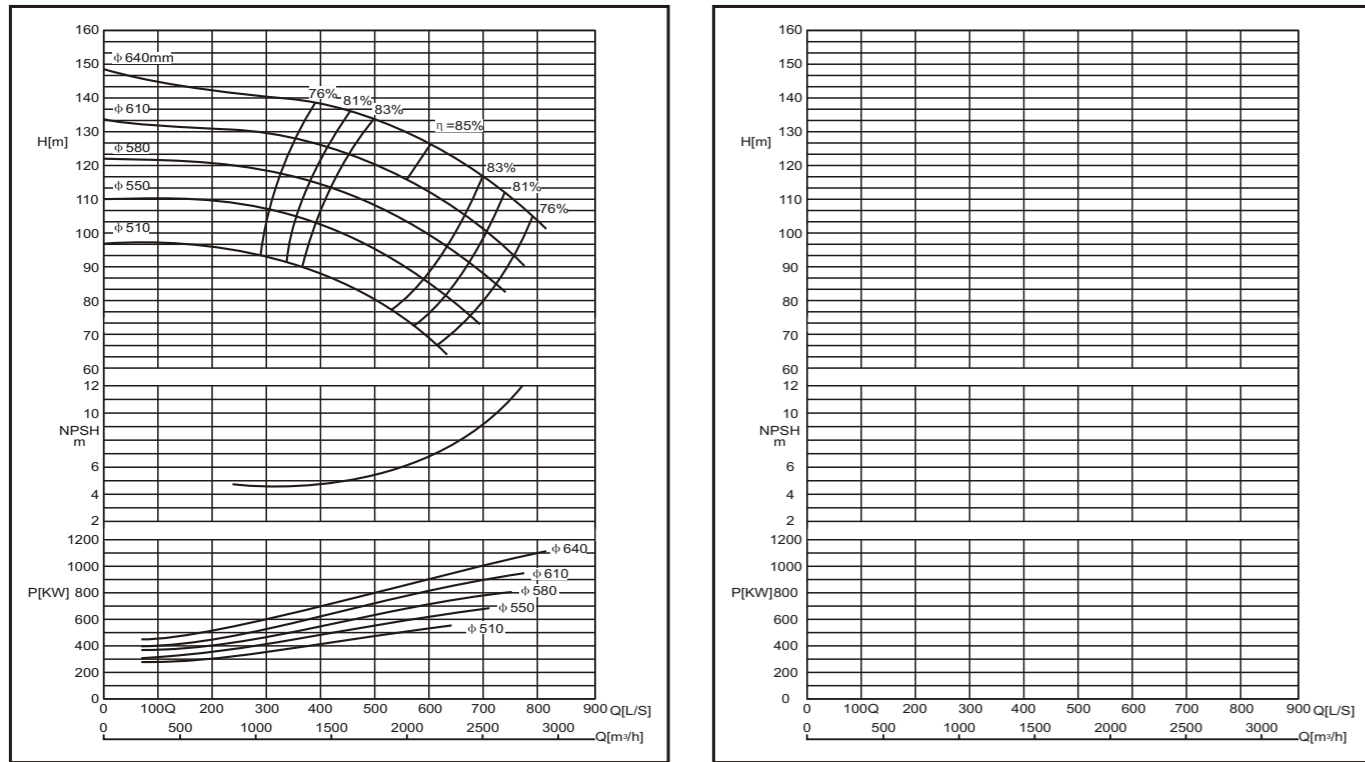

DMC卧式泵安装尺寸图 Installing dimensions of DMC pumps

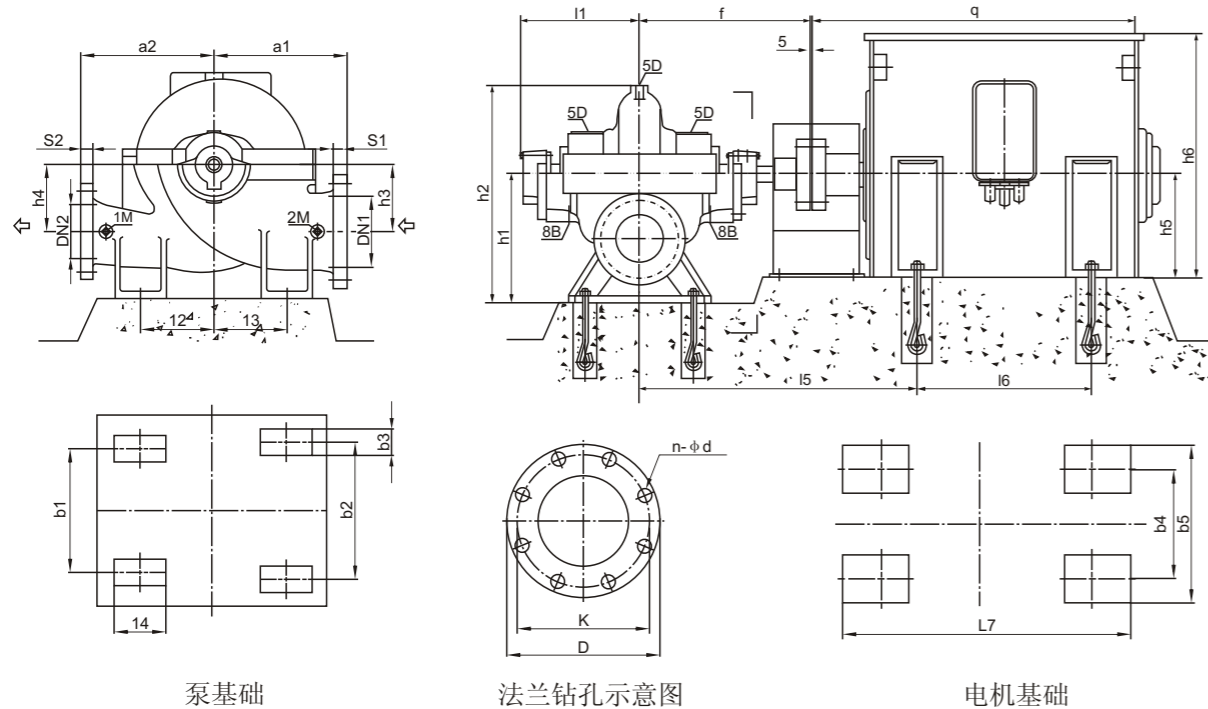

连接尺寸 connection dimensions:

- 1M、2M 压力表 Rp1/2 1M、2M pressure gauge Rp1/2
- 5D 排气孔 Rp1/2 5D air vent Rp1/2
- 6B 排液孔 Rp3/4 6B drain plug Rp3/4
- 8B 漏液排出孔 Rp3/4 8B drain plug Rp3/4

DMC400-540 E Curve n=1450r/min

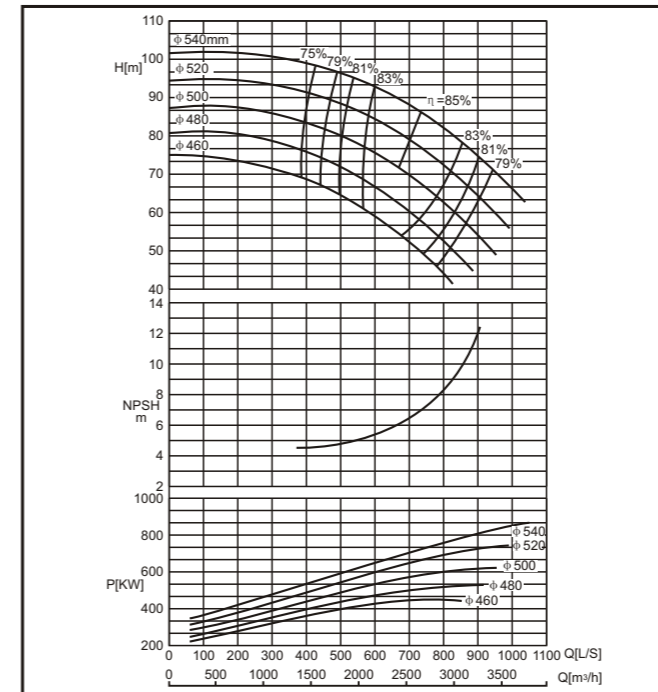

DMC400-540 F Curve n=1450r/min

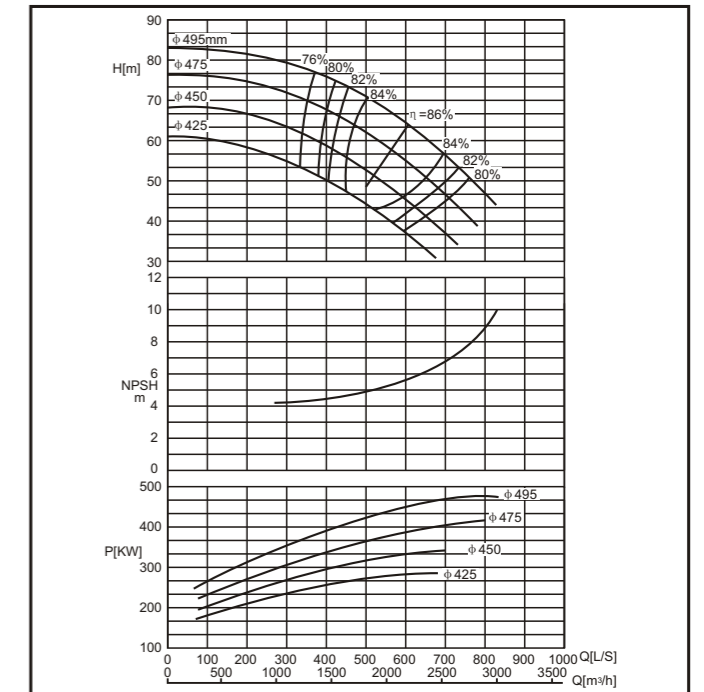

参数表 Standard performance

| 泵型号 Type | 流量 Capacity Q | | 扬程 Head m | 转速 Speed r/min | 轴功率 Shaft power kW | 效率 eff η % | 有效汽 蚀余量 NPSHa m | 电机功率 Motor power kW | 叶轮参 考直径 D(mm) |
|-----------------|---------------------|-------|-----------------|----------------------|-----------------------------|---------------------|--------------------------|------------------------------|---------------------|
| | m³/h | l/s | | | | | | | |
| DMC 350-620E | 1320 | 366.7 | 139 | 1450 | 657 | 76 | 7.0 | 1000 | 640 |
| | 2200 | 611.1 | 125 | | 881 | 85 | | | |
| | 2640 | 733.3 | 111 | | 985 | 81 | | | |
| | 1200 | 333.3 | 129 | | 552 | 76 | | | |
| | 2100 | 583.3 | 116 | | 743 | 85 | | | |
| | 2500 | 694.4 | 104 | | 874 | 81 | | | |
| | 1130 | 313.9 | 118 | | 478 | 76 | | | |
| | 1900 | 527.8 | 107 | | 651 | 85 | | | |
| | 2350 | 652.8 | 93 | | 721 | 82.5 | | | |
| | 1100 | 305.6 | 108 | | 426 | 76 | | | |
| | 1830 | 508.3 | 94 | | 566 | 84 | | | |
| | 2300 | 638.9 | 80 | | 618 | 81 | | | |
| 1020 | 283.3 | 94 | 343 | 76 | | | | | |
| 1700 | 472.2 | 83 | 457 | 84 | | | | | |
| 2150 | 597.2 | 69 | 518 | 78 | | | | | |

参数表 Standard performance

| 泵型号 Type | 流量 Capacity Q | | 扬程 Head m | 转速 Speed r/min | 轴功率 Shaft power kW | 效率 eff η % | 有效汽 蚀余量 NPSHa m | 电机功率 Motor power kW | 叶轮参 考直径 D(mm) |
|-----------------|---------------------|-------|-----------------|----------------------|-----------------------------|---------------------|--------------------------|------------------------------|---------------------|
| | m³/h | l/s | | | | | | | |
| DMC 400-540E | 1570 | 436.1 | 98.5 | 1450 | 550 | 76.5 | 7.0 | 800 | 540 |
| | 2630 | 730.6 | 86 | | 824 | 85 | | | |
| | 3420 | 950 | 70 | | 825 | 79 | | | |
| | 1500 | 416.7 | 91 | | 489 | 76 | | | |
| | 2500 | 694.4 | 79.5 | | 637 | 85 | | | |
| | 3250 | 902.8 | 64 | | 717 | 79 | | | |
| | 1440 | 400 | 83 | | 434 | 75 | | | |
| | 2400 | 666.7 | 72 | | 553 | 85 | | | |
| | 3120 | 866.7 | 57 | | 612 | 79 | | | |
| | 1380 | 383.3 | 76 | | 391 | 75 | | | |
| | 2305 | 640.3 | 64 | | 478 | 84 | | | |
| | 3000 | 833.3 | 50 | | 517 | 79 | | | |
| 1330 | 369.4 | 69 | 333 | 75 | | | | | |
| 2210 | 613.9 | 58 | 420 | 83 | | | | | |
| 2580 | 700 | 44 | 442 | 78 | | | | | |
| 1320 | 366.7 | 77 | 364 | 76 | | | | | |
| 2200 | 611.1 | 63.5 | 442 | 86 | | | | | |
| 2860 | 794.4 | 48 | 473 | 79 | | | | | |
| 1260 | 350 | 69.5 | 314 | 76 | | | | | |
| 2100 | 583.3 | 57 | 420 | 83 | | | | | |
| 2730 | 758.3 | 37 | 395 | 78 | | | | | |
| 1200 | 333.3 | 53.6 | 231 | 76 | | | | | |
| 1990 | 552.8 | 49.5 | 321 | 83.5 | | | | | |
| 2500 | 694.4 | 37 | 327 | 77 | | | | | |
| 1110 | 308.3 | 54 | 218 | 75 | | | | | |
| 1850 | 513.9 | 43 | 261 | 83 | | | | | |
| 2340 | 650 | 33 | 277 | 76 | | | | | |

主要外型尺寸 pump outline size

| 泵型号 type | 法兰尺寸 flange size | | | | | | | | | | 泵尺寸 pump size | | | | | | | | 泵重量 W.T kg |
|-------------|-------------------|----|-----|-----|--------|--------------------|----|-----|-----|--------|---------------|-----|-----|------|-----|-----|-----|-----|------------------|
| | 进口法兰 inlet flange | | | | | 出口法兰 outlet flange | | | | | | | | | | | | | |
| | DN1 | S1 | K | D | n-φd | DN2 | S2 | K | D | n-φd | a1 | a2 | h1 | h2 | h3 | h4 | l1 | f | |
| 350-620 | 400 | 48 | 550 | 610 | 16-φ34 | 350 | 44 | 490 | 550 | 16-φ34 | 740 | 670 | 775 | 1290 | 460 | 460 | 710 | 910 | 2120 |
| 400-540 | 500 | 48 | 650 | 710 | 20-φ34 | 400 | 40 | 525 | 585 | 16-φ30 | 730 | 700 | 820 | 1320 | 460 | 460 | 720 | 940 | 2380 |

连接尺寸 connection size

| 泵型号 type | 电机 Motor | | 12 | 13 | 14 | b1 | b2 | b3 | 15 | 16 | 17 | b4 | b5 | h5 | h6 | q | 地脚螺栓 anchor | | 电机最大重量 motor W.T |
|-------------|-------------|---------|-----|-----|-----|-----|-----|-----|------|------|------|-----|------|-----|------|------|-------------|----------|---------------------|
| | 型号 Type | 功率(kW) | | | | | | | | | | | | | | | 泵 pump | 电机 motor | |
| 350-620 | Y500-4(6kV) | 1000 | 385 | 445 | 120 | 560 | 810 | 120 | 1640 | 1250 | 1730 | 900 | 1010 | 500 | 1040 | 2550 | M36×600 | M36×600 | 4070 |
| | Y450-4(6kV) | 630-900 | | | | | | | 1480 | 1120 | 1620 | 800 | 910 | 450 | 935 | 2080 | | M30×600 | 3850 |
| | Y400-4(6kV) | 560 | | | | | | | 1460 | 1000 | 1510 | 710 | 810 | 400 | 835 | 1940 | | M30×600 | 2620 |
| 400-540 | Y450-4(6kV) | 630-900 | 455 | 505 | 220 | 720 | 970 | 120 | 1510 | 1120 | 1620 | 800 | 910 | 450 | 935 | 2080 | M36×600 | M30×600 | 3850 |
| | Y400-4(6kV) | 355-560 | | | | | | | 1490 | 1000 | 1510 | 710 | 810 | 400 | 835 | 1940 | | M24×500 | 2620 |
| | Y355L2-4 | 315 | | | | | | | 1525 | 630 | 808 | 610 | 730 | 355 | 860 | 1545 | | M24×500 | 1940 |

DMC400-620 E Curve n=1450r/min

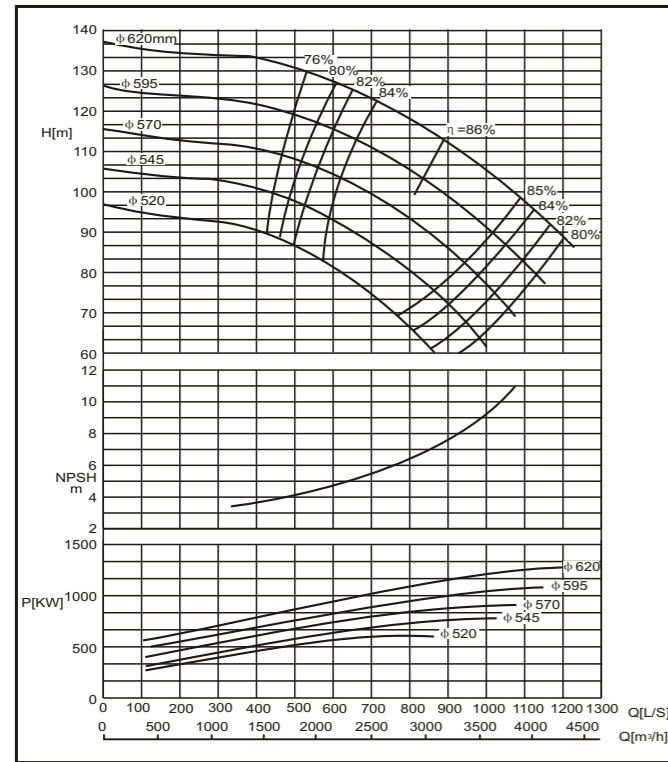

DMC400-620 F Curve n=1450r/min

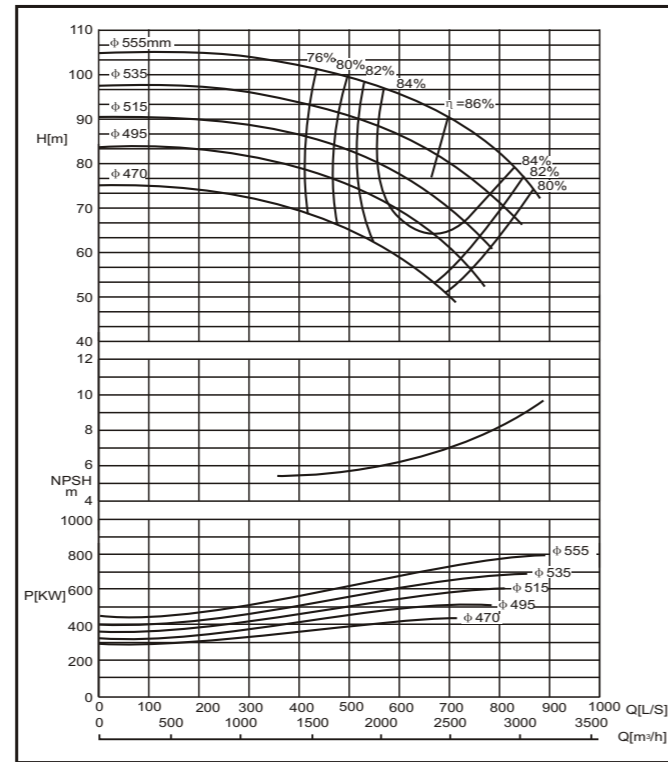

DMC500-510 E Curve n=960r/min

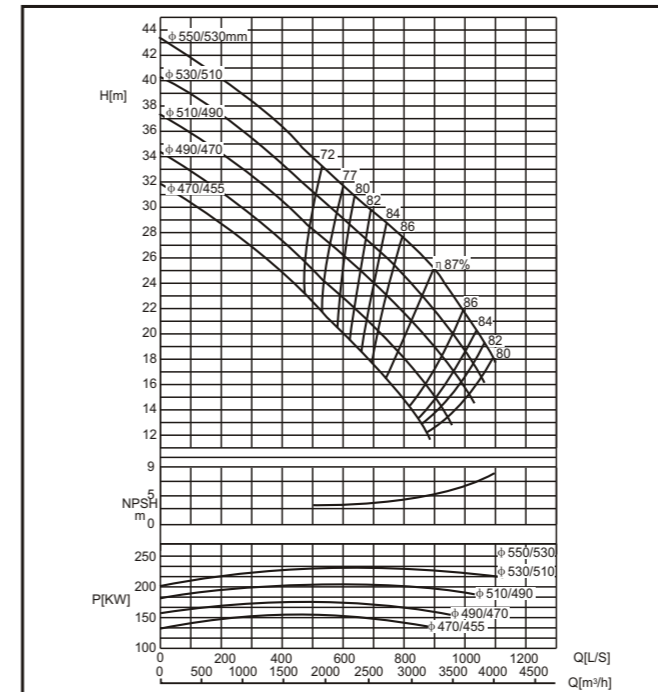

DMC500-510 F Curve n=960r/min

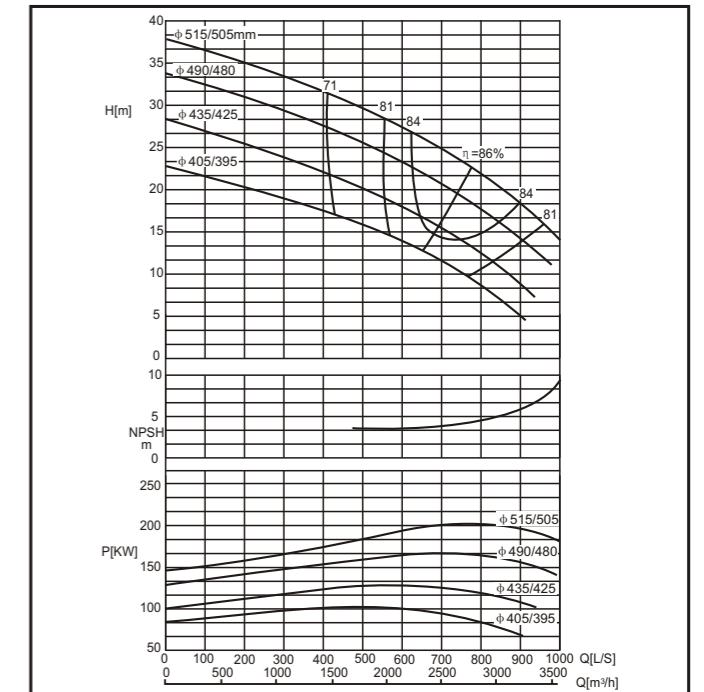

DMC卧式泵安装尺寸图 Installing dimensions of DMC pumps

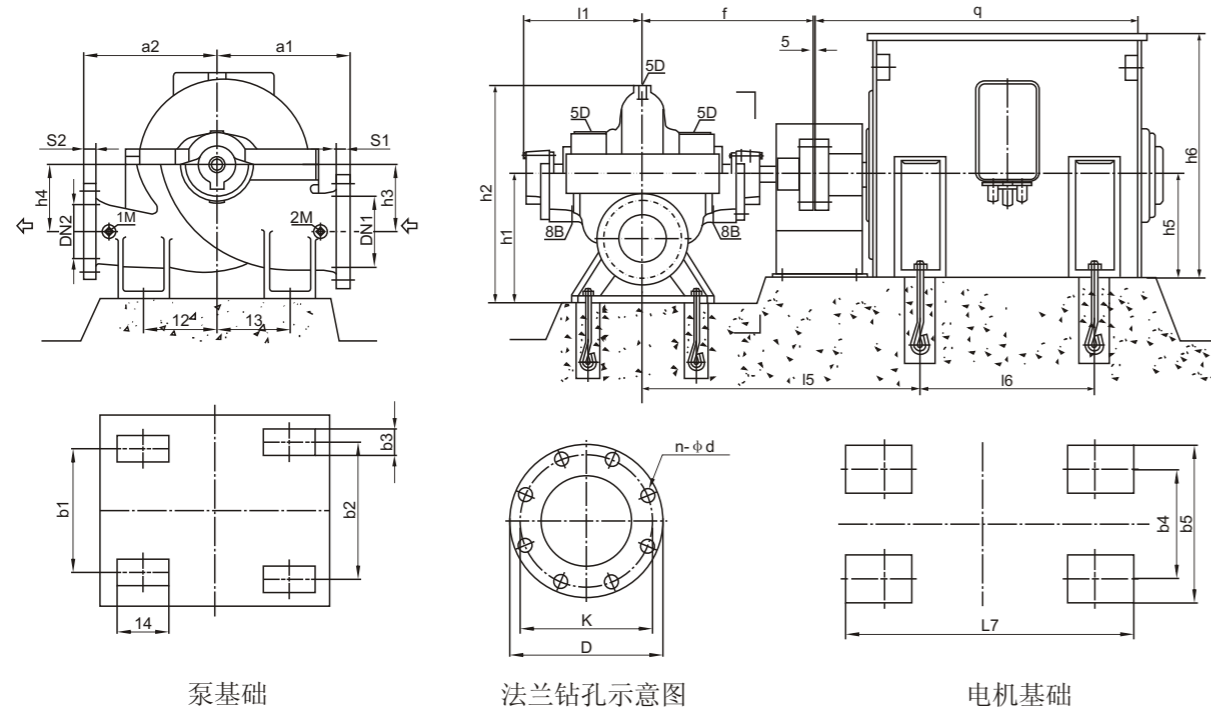

连接尺寸 connection dimensions:

- 1M、2M 压力表 Rp1/2 1M、2M pressure gauge Rp1/2
- 5D 排气孔 Rp1/2 5D air vent Rp1/2
- 6B 排液孔 Rp3/4 6B drain plug Rp3/4
- 8B 漏液排出孔 Rp3/4 8B drain plug Rp3/4

参数表 Standard performance

| 泵型号 Type | 流量 Capacity Q | 扬程 Head m | 转速 Speed r/min | 轴功率 Shaft power kW | 效率 eff η % | 有效汽 蚀余量 NPSHa m | 电机功率 Motor power kW | 叶轮参 考直径 D(mm) |
|-----------------|---------------------|-----------------|----------------------|-----------------------------|---------------------|--------------------------|------------------------------|---------------------|
| DMC 400-620E | 1890 | 525 | 129.5 | 877 | 76 | 7.5 | 1250 | 620 |
| | 3150 | 875 | 113 | 1127 | 86 | | 1400 | |
| | 4100 | 1139 | 93 | 1250 | 83 | | | |
| | 1800 | 500 | 119 | 767 | 76 | 7.0 | 1120 | 595 |
| | 3020 | 839 | 103 | 987 | 85.3 | | | |
| | 3920 | 1089 | 83 | 1080 | 82 | | | |
| | 1740 | 483 | 109 | 679 | 76 | 6.7 | 1120 | 570 |
| | 2895 | 804 | 92 | 847 | 85.6 | | | |
| | 3760 | 1044 | 87 | 1060 | 84 | | | |
| | 1650 | 458 | 89 | 577 | 77 | 6.0 | 800 | 545 |
| 2700 | 767 | 83 | 729 | 85.5 | | | | |
| 3550 | 986 | 64 | 773 | 80 | | | | |
| DMC 400-620F | 1580 | 439 | 89 | 491 | 78 | 5.7 | 710 | 520 |
| | 2630 | 737 | 72 | 603 | 85.5 | | | |
| | 3050 | 880 | 61.5 | 693 | 82 | | | |
| | 1500 | 417 | 101.5 | 545 | 76 | 6.8 | 800 | 555 |
| | 2485 | 690 | 90 | 708 | 86 | | | |
| | 3150 | 875 | 72 | 792 | 78 | | | |
| | 1440 | 400 | 94 | 485 | 85.3 | 6.5 | 710 | 535 |
| | 2400 | 667 | 82 | 629 | 86.8 | | | |
| | 3020 | 839 | 66 | 696 | 78 | | | |
| | 1440 | 400 | 79 | 409 | 75.8 | 5.5 | 630 | 515 |
| 2310 | 642 | 74.5 | 547 | 85.7 | | | | |
| 2845 | 790 | 60 | 596 | 78 | | | | |
| DMC 500-510E | 1890 | 540 | 33 | 877 | 76 | 7.5 | 1250 | 620 |
| | 3150 | 875 | 25 | 1127 | 86 | | 1400 | |
| | 3925 | 1090 | 18 | 1250 | 83 | | | |
| | 1855 | 515 | 31 | 679 | 76 | 7.0 | 1120 | 595 |
| | 2975 | 826.4 | 21 | 987 | 85.3 | | | |
| | 3800 | 1056 | 16.5 | 1080 | 82 | | | |
| | 1785 | 495 | 28.5 | 679 | 76 | 6.7 | 1120 | 570 |
| | 2975 | 826.4 | 21 | 987 | 85.3 | | | |
| | 3650 | 1014 | 14.3 | 1060 | 84 | | | |
| | 1680 | 466.7 | 23.2 | 491 | 78 | 5.7 | 710 | 520 |
| 2800 | 778 | 18.5 | 603 | 85.5 | | | | |
| 3420 | 950 | 13 | 773 | 80 | | | | |
| DMC 500-510F | 1600 | 444.4 | 24 | 545 | 76 | 6.8 | 800 | 555 |
| | 2670 | 742 | 16.5 | 708 | 86 | | | |
| | 3150 | 815 | 12 | 792 | 78 | | | |
| | 1465 | 407 | 31.3 | 485 | 85.3 | 6.5 | 710 | 535 |
| | 2375 | 771 | 22.5 | 629 | 86.8 | | | |
| | 3600 | 1000 | 14 | 696 | 78 | | | |
| | 1465 | 407 | 27.5 | 409 | 75.8 | 5.5 | 630 | 515 |
| | 2638 | 732 | 19.5 | 547 | 85.7 | | | |
| | 3430 | 953 | 12 | 596 | 78 | | | |
| | 1505 | 418 | 21.8 | 385 | 75 | 6.3 | 560 | 495 |
| 2450 | 681 | 15.8 | 480 | 85 | | | | |
| 3185 | 885 | 9.3 | 515 | 77 | | | | |
| DMC 500-510E | 1945 | 540 | 33 | 877 | 76 | 7.5 | 1250 | 620 |
| | 3240 | 900 | 25 | 1127 | 86 | | 1400 | |
| | 3925 | 1090 | 18 | 1250 | 83 | | | |
| | 1855 | 515 | 31 | 679 | 76 | 7.0 | 1120 | 595 |
| | 2975 | 826.4 | 21 | 987 | 85.3 | | | |
| | 3800 | 1056 | 16.5 | 1080 | 82 | | | |
| | 1785 | 495 | 28.5 | 679 | 76 | 6.7 | 1120 | 570 |
| | 2975 | 826.4 | 21 | 987 | 85.3 | | | |
| | 3650 | 1014 | 14.3 | 1060 | 84 | | | |
| | 1680 | 466.7 | 23.2 | 491 | 78 | 5.7 | 710 | 520 |
| 2800 | 778 | 18.5 | 603 | 85.5 | | | | |
| 3420 | 950 | 13 | 773 | 80 | | | | |
| DMC 500-510F | 1600 | 444.4 | 24 | 545 | 76 | 6.8 | 800 | 555 |
| | 2670 | 742 | 16.5 | 708 | 86 | | | |
| | 3150 | 815 | 12 | 792 | 78 | | | |
| | 1465 | 407 | 31.3 | 485 | 85.3 | 6.5 | 710 | 535 |
| | 2375 | 771 | 22.5 | 629 | 86.8 | | | |
| | 3600 | 1000 | 14 | 696 | 78 | | | |
| | 1465 | 407 | 27.5 | 409 | 75.8 | 5.5 | 630 | 515 |
| | 2638 | 732 | 19.5 | 547 | 85.7 | | | |
| | 3430 | 953 | 12 | 596 | 78 | | | |
| | 1505 | 418 | 21.8 | 385 | 75 | 6.3 | 560 | 495 |
| 2450 | 681 | 15.8 | 480 | 85 | | | | |
| 3185 | 885 | 9.3 | 515 | 77 | | | | |

参数表 Standard performance

| 泵型号 Type | 流量 Capacity Q | 扬程 Head m | 转速 Speed r/min | 轴功率 Shaft power kW | 效率 eff η % | 有效汽 蚀余量 NPSHa m | 电机功率 Motor power kW | 叶轮参 考直径 D(mm) |
|-----------------|---------------------|-----------------|----------------------|-----------------------------|---------------------|--------------------------|------------------------------|---------------------|
| DMC 400-620E | 1890 | 525 | 129.5 | 877 | 76 | 7.5 | 1250 | 620 |
| | 3150 | 875 | 113 | 1127 | 86 | | 1400 | |
| | 4100 | 1139 | 93 | 1250 | 83 | | | |
| | 1800 | 500 | 119 | 767 | 76 | 7.0 | 1120 | 595 |
| | 3020 | 839 | 103 | 987 | 85.3 | | | |
| | 3920 | 1089 | 83 | 1080 | 82 | | | |
| | 1740 | 483 | 109 | 679 | 76 | 6.7 | 1120 | 570 |
| | 2895 | 804 | 92 | 847 | 85.6 | | | |
| | 3760 | 1044 | 87 | 1060 | 84 | | | |
| | 1650 | 458 | 89 | 577 | 77 | 6.0 | 800 | 545 |
| 2700 | 767 | 83 | 729 | 85.5 | | | | |
| 3550 | 986 | 64 | 773 | 80 | | | | |
| DMC 400-620F | 1580 | 439 | 89 | 491 | 78 | 5.7 | 710 | 520 |
| | 2630 | 737 | 72 | 603 | 85.5 | | | |
| | 3050 | 880 | 61.5 | 693 | 82 | | | |
| | 1500 | 417 | 101.5 | 545 | 76 | 6.8 | 800 | 555 |
| | 2485 | 690 | 90 | 708 | 86 | | | |
| | 3150 | 875 | 72 | 792 | 78 | | | |
| | 1440 | 400 | 94 | 485 | 85.3 | 6.5 | 710 | 535 |
| | 2400 | 667 | 82 | 629 | 86.8 | | | |
| | 3020 | 839 | 66 | 696 | 78 | | | |
| | 1440 | 400 | 79 | 409 | 75.8 | 5.5 | 630 | 515 |
| 2310 | 642 | 74.5 | 547 | 85.7 | | | | |
| 2845 | 790 | 60 | 596 | 78 | | | | |
| DMC 500-510E | 1890 | 540 | 33 | 877 | 76 | 7.5 | 1250 | 620 |
| | 3150 | 875 | 25 | 1127 | 86 | | 1400 | |
| | 3925 | 1090 | 18 | 1250 | 83 | | | |
| | 1855 | 515 | 31 | 679 | 76 | 7.0 | 1120 | 595 |
| | 2975 | 826.4 | 21 | 987 | 85.3 | | | |
| | 3800 | 1056 | 16.5 | 1080 | 82 | | | |
| | 1785 | 495 | 28.5 | 679 | 76 | 6.7 | 1120 | 570 |
| | 2975 | 826.4 | 21 | 987 | 85.3 | | | |
| | 3650 | 1014 | 14.3 | 1060 | 84 | | | |
| | 1680 | 466.7 | 23.2 | 491 | 78 | 5.7 | 710 | 520 |
| 2800 | 778 | 18.5 | 603 | 85.5 | | | | |
| 3420 | 950 | 13 | 773 | 80 | | | | |
| DMC 500-510F | 1600 | 444.4 | 24 | 545 | 76 | 6.8 | 800 | 555 |
| | 2670 | 742 | 16.5 | 708 | 86 | | | |
| | 3150 | 815 | 12 | 792 | 78 | | | |
| | 1465 | 407 | 31.3 | 485 | 85.3 | 6.5 | 710 | 535 |
| | 2375 | 771 | 22.5 | 629 | 86.8 | | | |
| | 3600 | 1000 | 14 | 696 | 78 | | | |
| | 1465 | 407 | 27.5 | 409 | 75.8 | 5.5 | 630 | 515 |
| | 2638 | 732 | 19.5 | 547 | 85.7 | | | |
| | 3430 | 953 | 12 | 596 | 78 | | | |
| | 1505 | 418 | 21.8 | 385 | 75 | 6.3 | 560 | 495 |
| 2450 | 681 | 15.8 | 480 | 85 | | | | |
| 3185 | 885 | 9.3 | 515 | 77 | | | | |

主要外型尺寸 pump outline size

| 泵型号 type | 法兰尺寸 flange size | | | | | | | | | | 泵尺寸 pump size | | | | | | | 泵重量 W.T kg | |
|-------------|-------------------|----|-----|-----|--------|--------------------|----|-----|-----|--------|---------------|-----|-----|------|-----|-----|-----|------------------|------|
| | 进口法兰 inlet flange | | | | | 出口法兰 outlet flange | | | | | 泵尺寸 pump size | | | | | | | | |
| | DN1 | S1 | K | D | n-φd | DN2 | S2 | K | D | n-φd | a1 | a2 | h1 | h2 | h3 | h4 | l1 | | f |
| 400-620 | 500 | 56 | 650 | 710 | 20-φ34 | 400 | 48 | 525 | 585 | 16-φ30 | 800 | 700 | 850 | 1380 | 490 | 490 | 740 | 955 | 2760 |
| 500-510 | 600 | 54 | 770 | 840 | 20-φ41 | 500 | 46 | 650 | 710 | 20-φ34 | 850 | 550 | 900 | 1450 | 475 | 475 | 820 | 1025 | 1528 |

连接尺寸 connection size

| 泵型号 type | 电机 Motor | | 地脚螺栓 anchor | | | | | | | | | | | | | | | 电机最大重量 motor W.T |
|-------------|-------------|-----------|-------------|-----|-----|-----|------|-----|------|------|------|------|------|-----|------|------|---------|---------------------|
| | 型号 Type | 功率 (kW) | 泵 pump | | | | | | | | | | | | | | | |
| | 12 | 13 | 14 | b1 | b2 | b3 | 15 | 16 | 17 | b4 | b5 | h5 | h6 | q | | | | |
| 400-620 | Y500-4(6kV) | 1400-1000 | 455 | 555 | 220 | 720 | 970 | 120 | 1685 | 1250 | 1730 | 900 | 1010 | 500 | 1040 | 2550 | M36×600 | 4600 |
| | Y450-4(6kV) | 630-900 | | | | | | | 1525 | 1120 | 1620 | 800 | 910 | 450 | 935 | 2080 | M42×800 | 3850 |
| | Y400-4(6kV) | 500-560 | | | | | | | | 1505 | 1000 | 1510 | 710 | 810 | 400 | 835 | 1940 | M30×600 |
| 500-510 | Y355L1-6 | 280 | | | | | | | 1454 | 630 | 808 | 610 | 730 | 355 | 860 | 1545 | M36×600 | 1940 |
| | Y355M-6 | 220-250 | 250 | 400 | 120 | 820 | 1120 | 120 | 1454 | 560 | 808 | 610 | 730 | 355 | 860 | 1545 | M24×500 | 1800 |
| | Y315L-6 | 160-200 | | | | | | | 1416 | 508 | 720 | 508 | 640 | 315 | 865 | 1545 | | 1190 |
| | Y315M-6 | 132 | | | | | | | 1416 | 457 | 660 | 508 | 640 | 315 | 865 | 1340 | | 1100 |

DMC500-640 E Curve n=960r/min

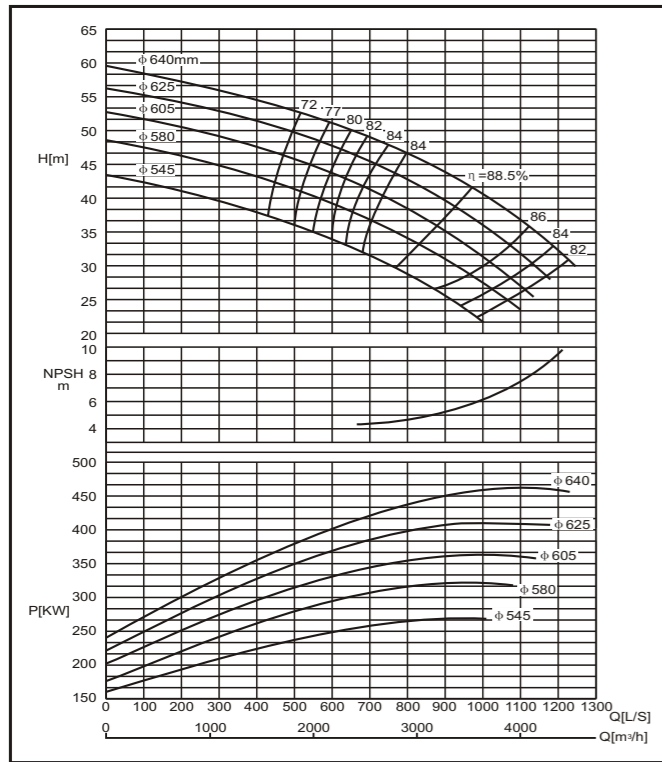

DMC500-640 F Curve n=960r/min

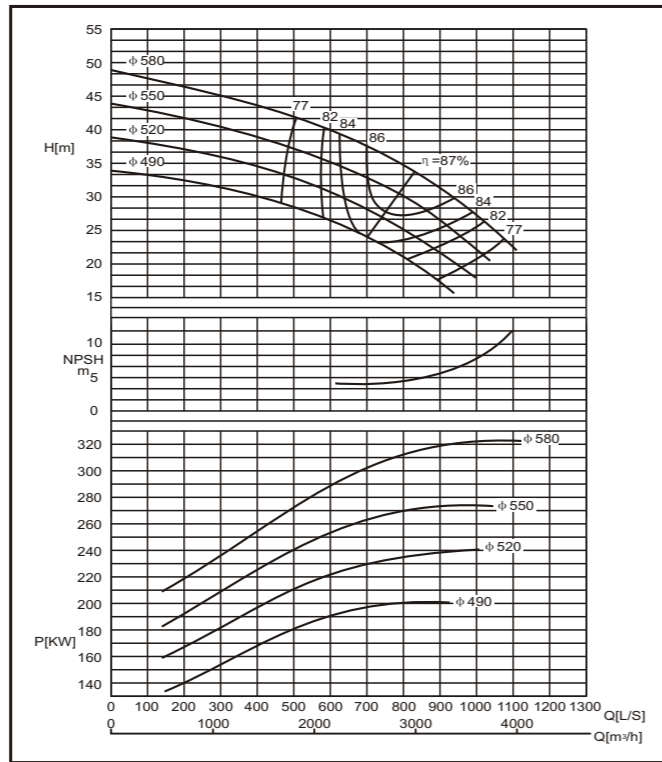

DMC卧式泵安装尺寸图 Installing dimensions of DMC pumps

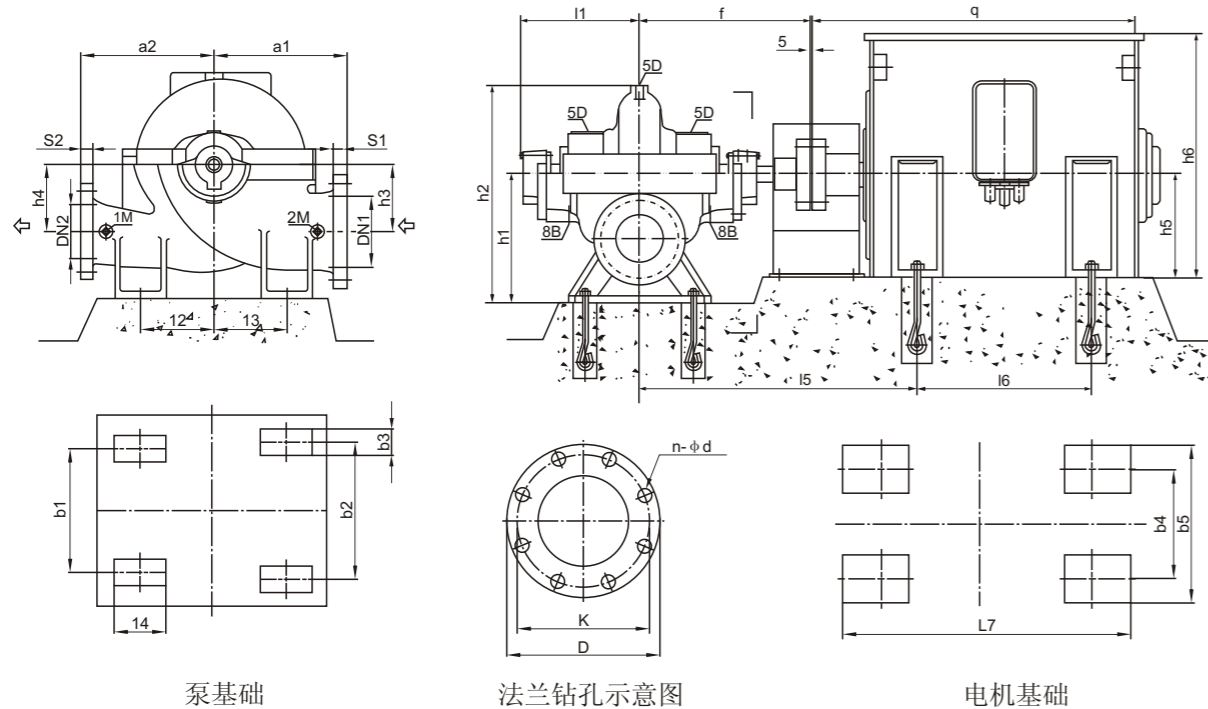

连接尺寸 connection dimensions:

- 1M、2M 压力表 Rp1/2 1M、2M pressure gauge Rp1/2
- 5D 排气孔 Rp1/2 5D air vent Rp1/2
- 6B 排液孔 Rp3/4 6B drain plug Rp3/4
- 8B 漏液排出孔 Rp3/4 8B drain plug Rp3/4

DMC500-700 E Curve n=960r/min

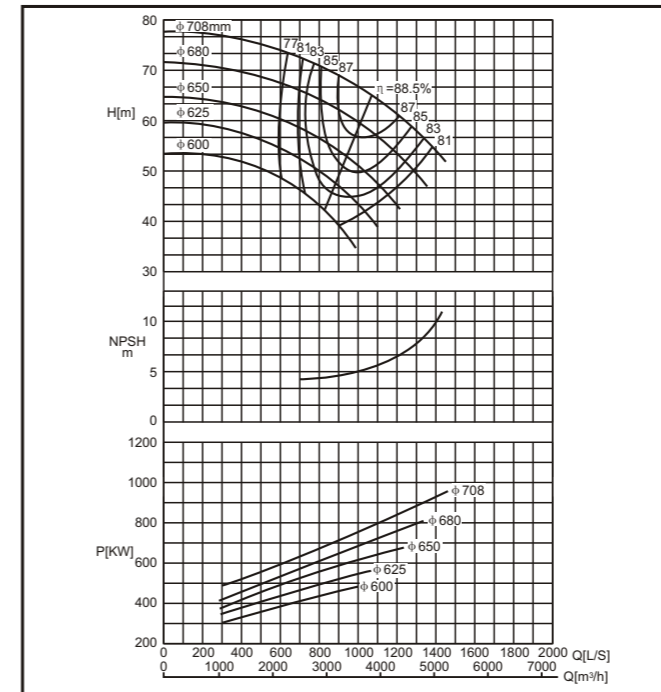

DMC500-700 F Curve n=960r/min

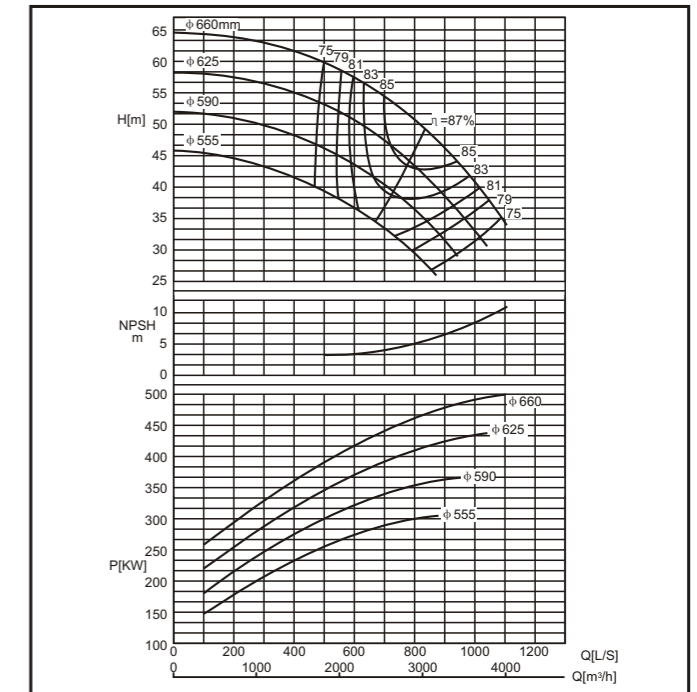

参数表 Standard performance

| 泵型号 Type | 流量 Capacity Q | | 扬程 Head m | 转速 Speed r/min | 轴功率 Shaft power kW | 效率 eff η % | 有效汽 蚀余量 NPSHa m | 电机功率 Motor power kW | 叶轮参 考直径 D(mm) |
|-----------------|---------------------|------|-----------------|----------------------|-----------------------------|---------------------|--------------------------|------------------------------|---------------------|
| | m³/h | l/s | | | | | | | |
| DMC 500-640E | 1875 | 521 | 52.5 | 960 | 372 | 72 | 6.0 | 500 | 640 |
| | 3528 | 980 | 41.0 | | | | | | |
| | 4500 | 1250 | 30 | | | | | | |
| | 1800 | 500 | 50 | | | | | | |
| | 3240 | 928 | 38.7 | | | | | | |
| | 3610 | 1000 | 28.5 | | | | | | |
| | 1710 | 475 | 46.5 | | | | | | |
| | 3170 | 881 | 36 | | | | | | |
| | 4030 | 1119 | 26.5 | | | | | | |
| | 1620 | 450 | 42.5 | | | | | | |
| 3020 | 839 | 33.2 | | | | | | | |
| 3830 | 1064 | 25 | | | | | | | |
| 1530 | 425 | 37.5 | | | | | | | |
| 2800 | 778 | 29.8 | | | | | | | |
| 3600 | 1000 | 22 | | | | | | | |
| 1800 | 500 | 42 | | | | | | | |
| 2990 | 831 | 34 | | | | | | | |
| 3885 | 1079 | 23 | | | | | | | |
| 1700 | 472 | 38 | | | | | | | |
| 2835 | 788 | 30.2 | | | | | | | |
| 3685 | 1024 | 21 | | | | | | | |
| 1640 | 456 | 33.8 | | | | | | | |
| 2730 | 758 | 27.8 | | | | | | | |
| 3510 | 975 | 18.5 | | | | | | | |
| 1545 | 429 | 20.6 | | | | | | | |
| 2575 | 715 | 24 | | | | | | | |
| 3280 | 911 | 18 | | | | | | | |
| 217 | 72 | 4.5 | 315 | 545 | | | | | |
| 267 | 77 | 5.0 | 355 | 580 | | | | | |
| 318 | 87 | 5.0 | 355 | 580 | | | | | |
| 316 | 77 | 4.5 | 315 | 550 | | | | | |
| 231 | 76 | 4.5 | 315 | 550 | | | | | |
| 271 | 86 | 4.3 | 280 | 520 | | | | | |
| 236 | 75 | 4.0 | 250 | 490 | | | | | |
| 167 | 74.5 | 4.0 | 250 | 490 | | | | | |
| 198 | 85 | 4.0 | 250 | 490 | | | | | |
| 216 | 74.5 | 4.0 | 250 | 490 | | | | | |

参数表 Standard performance

| 泵型号 Type | 流量 Capacity Q | | 扬程 Head m | 转速 Speed r/min | 轴功率 Shaft power kW | 效率 eff η % | 有效汽 蚀余量 NPSHa m | 电机功率 Motor power kW | 叶轮参 考直径 D(mm) |
|-----------------|---------------------|------|-----------------|----------------------|-----------------------------|---------------------|--------------------------|------------------------------|---------------------|
| | m³/h | l/s | | | | | | | |
| DMC 500-700E | 2270 | 631 | 73 | 960 | 586 | 77 | 6.0 | 900 | 708 |
| | 3850 | 1069 | 65 | | | | | | |
| | 5040 | 1400 | 54 | | | | | | |
| | 2200 | 611 | 67.5 | | | | | | |
| | 3670 | 1019 | 59.5 | | | | | | |
| | 4770 | 1325 | 48 | | | | | | |
| | 2050 | 569 | 61 | | | | | | |
| | 3420 | 950 | 53 | | | | | | |
| | 4350 | 1208 | 42.5 | | | | | | |
| | 1920 | 533 | 55.7 | | | | | | |
| 3200 | 889 | 47.8 | | | | | | | |
| 3960 | 1100 | 39 | | | | | | | |
| 1810 | 503 | 50 | | | | | | | |
| 3020 | 839 | 42 | | | | | | | |
| 3660 | 999 | 35 | | | | | | | |
| 333 | 74 | 4.5 | 500 | 600 | | | | | |
| 406 | 85 | 4.5 | 500 | 600 | | | | | |
| 446 | 76 | 4.5 | 500 | 600 | | | | | |
| 1800 | 500 | 60 | | | | | | | |
| 3005 | 835 | 49 | | | | | | | |
| 3905 | 1085 | 35 | | | | | | | |
| 1680 | 467 | 53.5 | | | | | | | |
| 2800 | 775 | 44.2 | | | | | | | |
| 3640 | 1011 | 32.5 | | | | | | | |
| 1600 | 444 | 47.5 | | | | | | | |
| 2640 | 733 | 39.4 | | | | | | | |
| 3360 | 933 | 29.2 | | | | | | | |
| 1450 | 403 | 41.4 | | | | | | | |
| 2410 | 669 | 34.5 | | | | | | | |
| 3132 | 870 | 26.5 | | | | | | | |
| 392 | 75 | 6.0 | 560 | 660 | | | | | |
| 461 | 87 | 6.0 | 560 | 660 | | | | | |
| 496 | 75 | 6.0 | 560 | 660 | | | | | |
| 331 | 74 | 5.0 | 450 | 625 | | | | | |
| 392 | 86 | 5.0 | 450 | 625 | | | | | |
| 429 | 75 | 5.0 | 450 | 625 | | | | | |
| 284 | 73 | 4.3 | 400 | 590 | | | | | |
| 333 | 85 | 4.3 | 400 | 590 | | | | | |
| 361 | 74 | 4.3 | 400 | 590 | | | | | |
| 227 | 72 | 4.0 | 355 | 555 | | | | | |
| 269 | 84 | 4.0 | 355 | 555 | | | | | |
| 305 | 74 | 4.0 | 355 | 555 | | | | | |

主要外型尺寸 pump outline size

| 泵型号 type | 法兰尺寸 flange size | | | | | | | | | | 泵尺寸 pump size | | | | | | 泵重量 W.T kg | | |
|-------------|-------------------|----|-----|-----|--------|--------------------|----|-----|-----|--------|---------------|-----|------|------|-----|-----|------------------|------|------|
| | 进口法兰 inlet flange | | | | | 出口法兰 outlet flange | | | | | a1 | a2 | h1 | h2 | h3 | h4 | | l1 | f |
| | DN1 | S1 | K | D | n-φd | DN2 | S2 | K | D | n-φd | | | | | | | | | |
| 500-640 | 600 | 54 | 770 | 845 | 20-φ41 | 500 | 48 | 650 | 710 | 20-φ34 | 850 | 800 | 920 | 1520 | 495 | 495 | 900 | 1115 | 2301 |
| 500-700 | 600 | 54 | 770 | 845 | 20-φ41 | 500 | 48 | 650 | 710 | 20-φ34 | 1050 | 800 | 1000 | 1620 | 550 | 620 | 855 | 1085 | 2967 |

连接尺寸 connection size

| 泵型号 type | 电机 Motor | | 12 | 13 | 14 | b1 | b2 | b3 | 15 | 16 | 17 | b4 | b5 | h5 | h6 | q | 地脚螺栓 anchor | | 电机最大重量 motor W.T |
|-------------|-------------|---------|-----|-----|-----|-----|------|-----|------|------|------|-----|------|-----|------|------|-------------|----------|---------------------|
| | 型号 Type | 功率(kW) | | | | | | | | | | | | | | | 泵 pump | 电机 motor | |
| 500-640 | Y400-6(6kV) | 355-500 | 450 | 450 | 220 | 820 | 1120 | 120 | 1665 | 1000 | 1510 | 710 | 810 | 400 | 835 | 1940 | M36×600 | M30×600 | 2620 |
| | Y355-6(6kV) | 250-315 | | | | | | | 1645 | 900 | 1420 | 630 | 770 | 355 | 780 | 1820 | | M24×500 | 2160 |
| | Y355L1-6 | 280 | | | | | | | 1544 | 630 | 808 | 610 | 730 | 355 | 860 | 1545 | | M30×600 | 1940 |
| 500-700 | Y500-6(6kV) | 1000 | 500 | 600 | 220 | 820 | 1220 | 120 | 1815 | 1250 | 1730 | 900 | 1010 | 500 | 1040 | 2550 | M36×600 | M36×600 | 4070 |
| | Y450-6(6kV) | 630-900 | | | | | | | 1655 | 1120 | 1620 | 800 | 910 | 450 | 935 | 2080 | | M30×600 | 3850 |
| | Y400-6(6kV) | 355-560 | | | | | | | 1635 | 1000 | 1510 | 710 | 810 | 400 | 835 | 1940 | | M30×600 | 2620 |

DMC500-790 E Curve n=960r/min

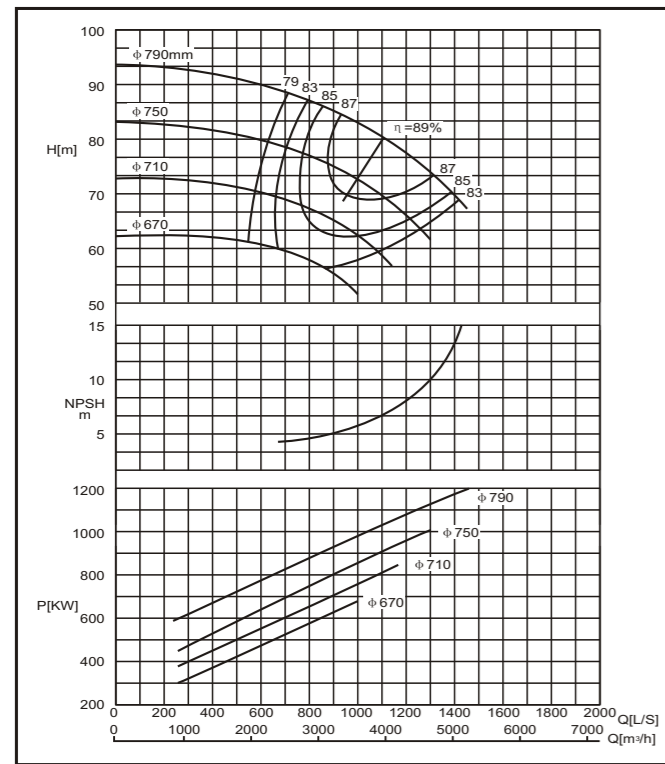

DMC500-790 F Curve n=960r/min

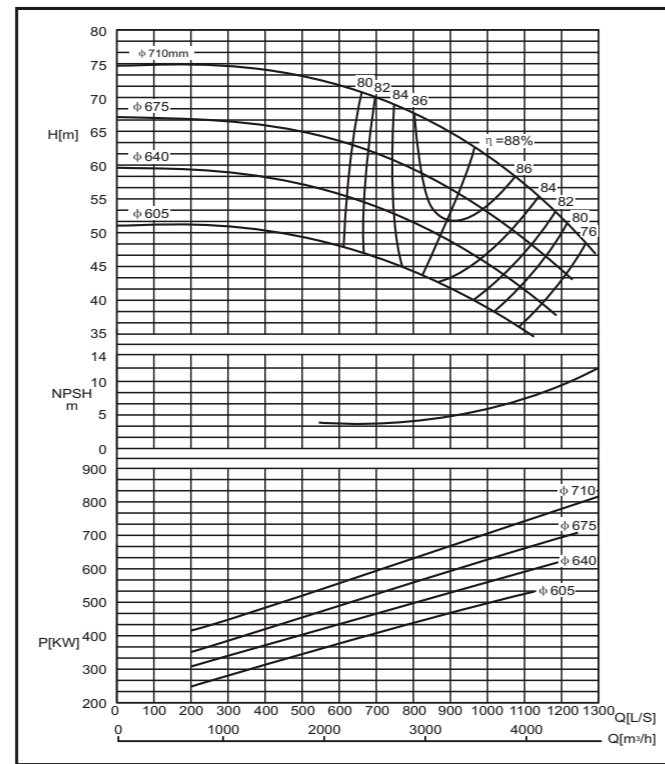

DMC卧式泵安装尺寸图 Installing dimensions of DMC pumps

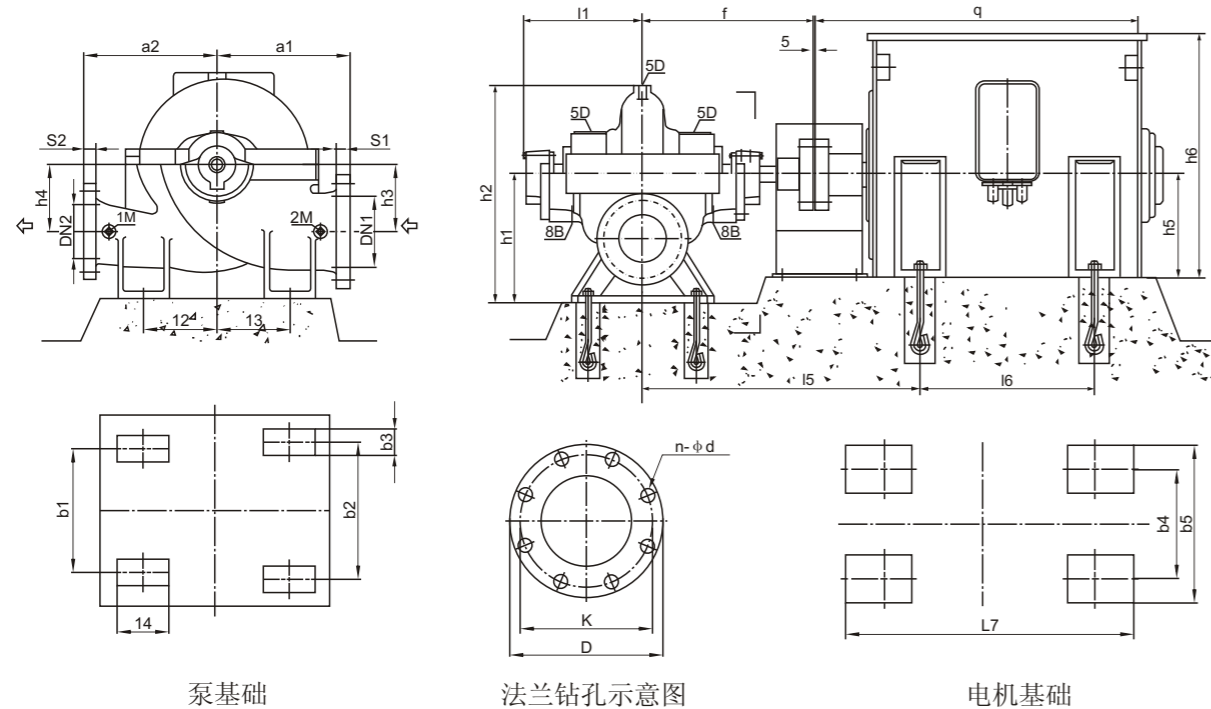

连接尺寸 connection dimensions:

- 1M、2M 压力表 Rp1/2 1M、2M pressure gauge Rp1/2
- 5D 排气孔 Rp1/2 5D air vent Rp1/2
- 6B 排液孔 Rp3/4 6B drain plug Rp3/4
- 8B 漏液排出孔 Rp3/4 8B drain plug Rp3/4

DMC500-890 E Curve n=960r/min

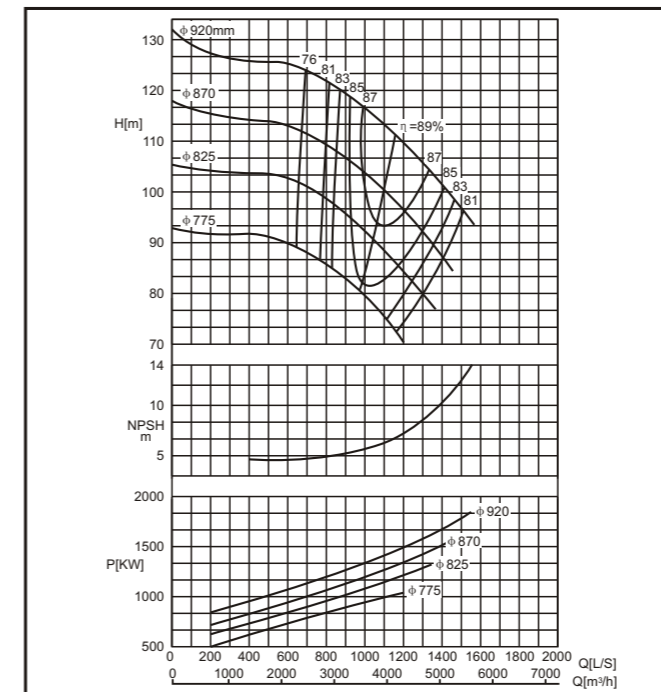

DMC500-890 F Curve n=960r/min

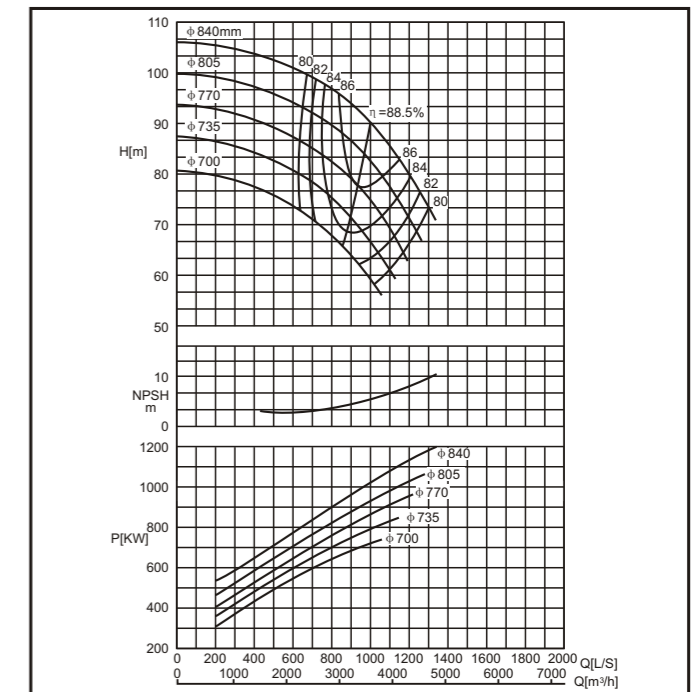

参数表 Standard performance

| 泵型号 Type | 流量 Capacity Q | | 扬程 Head m | 转速 Speed r/min | 轴功率 Shaft power kW | 效率 eff % | 有效汽 蚀余量 NPSHa m | 电机功率 Motor power kW | 叶轮参 考直径 D(mm) |
|-----------------|---------------------|------|-----------------|----------------------|-----------------------------|----------------|--------------------------|------------------------------|---------------------|
| | m³/h | l/s | | | | | | | |
| DMC 500-790E | 2580 | 717 | 88.5 | 960 | 787 | 79 | 7.1 | 1120 | 790 |
| | 3960 | 1100 | 80 | | 969 | 89 | | 1250 | |
| | 5150 | 1431 | 68 | | 1163 | 82 | | | |
| | 2160 | 600 | 80 | | 603 | 78 | | 900 | |
| | 3860 | 1000 | 72.8 | | 811 | 88 | | 1120 | |
| | 4680 | 1300 | 62 | | 975 | 81 | | | |
| DMC 500-790F | 1930 | 536 | 71 | 960 | 484 | 77 | 5.8 | 800 | 710 |
| | 3220 | 894 | 65.5 | | 660 | 87 | | 800 | |
| | 4100 | 1139 | 57 | | 795 | 80 | | | |
| | 1710 | 475 | 62 | | 380 | 76 | | 630 | |
| | 2850 | 792 | 58 | | 523 | 86 | | 710 | |
| | 3600 | 1000 | 51.8 | | 643 | 79 | | | |
| DMC 500-890E | 2375 | 660 | 70.8 | 960 | 572 | 80 | 5.8 | 800 | 710 |
| | 3492 | 970 | 62.5 | | 675 | 88 | | | |
| | 4550 | 1264 | 48 | | 793 | 75 | | | |
| | 2000 | 556 | 64 | | 447 | 78 | | 710 | |
| | 3330 | 925 | 56 | | 584 | 87 | | 800 | |
| | 4350 | 1208 | 44 | | 695 | 75 | | | |
| DMC 500-890F | 1900 | 528 | 57 | 960 | 383 | 77 | 4.5 | 560 | 640 |
| | 3150 | 875 | 50 | | 499 | 86 | | 630 | |
| | 4150 | 1153 | 39.3 | | 600 | 74 | | | |
| | 1780 | 494 | 49 | | 312 | 76 | | 500 | |
| | 2970 | 825 | 43.6 | | 415 | 85 | | 560 | |
| | 3900 | 1083 | 36 | | 516 | 74 | | | |

参数表 Standard performance

| 泵型号 Type | 流量 Capacity Q | | 扬程 Head m | 转速 Speed r/min | 轴功率 Shaft power kW | 效率 eff % | 有效汽 蚀余量 NPSHa m | 电机功率 Motor power kW | 叶轮参 考直径 D(mm) |
|-----------------|---------------------|------|-----------------|----------------------|-----------------------------|----------------|--------------------------|------------------------------|---------------------|
| | m³/h | l/s | | | | | | | |
| DMC 500-890E | 2520 | 700 | 124 | 960 | 1119 | 76 | 7.0 | 1600 | 920 |
| | 4230 | 1175 | 112 | | 1449 | 89 | | 1800 | |
| | 5500 | 1528 | 80 | | 1787 | 80 | | | |
| | 2400 | 667 | 112 | | 963 | 76 | | 1400 | |
| | 4000 | 1111 | 100 | | 1237 | 88 | | 1600 | |
| | 5200 | 1444 | 86 | | 1541 | 79 | | | |
| DMC 500-890F | 2270 | 631 | 102.5 | 960 | 845 | 75 | 6.0 | 1250 | 825 |
| | 3790 | 1053 | 90.5 | | 1073 | 87 | | 1400 | |
| | 4930 | 1369 | 77 | | 1325 | 79 | | | |
| | 2150 | 597 | 90 | | 712 | 74 | | 1120 | |
| | 3550 | 986 | 80.5 | | 905 | 86 | | 1250 | |
| | 4320 | 1200 | 70.5 | | 1077 | 77 | | | |

主要外型尺寸 pump outline size

| 泵型号 type | 法兰尺寸 flange size | | | | | | | | | | 泵尺寸 pump size | | | | | | 泵重量 W.T kg | | |
|-------------|-------------------|----|-----|-----|--------|--------------------|----|-----|-----|--------|---------------|-----|------|------|-----|-----|------------------|------|------|
| | 进口法兰 inlet flange | | | | | 出口法兰 outlet flange | | | | | a1 | a2 | h1 | h2 | h3 | h4 | | l1 | f |
| | DN1 | S1 | K | D | n-φd | DN2 | S2 | K | D | n-φd | | | | | | | | | |
| 500-790 | 600 | 54 | 770 | 845 | 20-φ41 | 500 | 46 | 650 | 710 | 20-φ34 | 1000 | 900 | 1050 | 1710 | 600 | 600 | 900 | 1175 | 3483 |
| 500-890 | 600 | 54 | 770 | 845 | 20-φ41 | 500 | 46 | 650 | 710 | 20-φ34 | 1050 | 950 | 1100 | 1810 | 650 | 650 | 920 | 1210 | 4659 |

连接尺寸 connection size

| 泵型号 type | 电机 Motor | | 12 | 13 | 14 | b1 | b2 | b3 | 15 | 16 | 17 | b4 | b5 | h5 | h6 | q | 地脚螺栓 anchor | | 电机最大重量 motor W.T |
|-------------|-------------|-----------|-----|-----|-----|-----|------|-----|------|------|------|------|------|-----|------|------|-------------|----------|---------------------|
| | 型号 Type | 功率(kW) | | | | | | | | | | | | | | | 泵 pump | 电机 motor | |
| 500-790 | Y400-6(6kV) | 355-500 | 550 | 650 | 220 | 845 | 1220 | 120 | 1725 | 1000 | 1510 | 710 | 810 | 400 | 835 | 1940 | M36×600 | M30×600 | 2520 |
| | Y355-6(6kV) | 250-315 | | | | | | | 1705 | 900 | 1420 | 630 | 770 | 355 | 780 | 1820 | | M24×500 | 2160 |
| | Y355L1-6 | 280 | | | | | | | 1604 | 630 | 808 | 610 | 730 | 355 | 860 | 1545 | | | 1940 |
| 500-890 | Y560-6(6kV) | 1600-1800 | 600 | 700 | 220 | 870 | 1120 | 120 | 1965 | 1400 | 1880 | 1000 | 1130 | 560 | 1160 | 2715 | M42×800 | M36×600 | 5420 |
| | Y500-6(6kV) | 1000-1400 | | | | | | | 1940 | 1250 | 1730 | 900 | 1010 | 500 | 1040 | 2550 | | M30×600 | 4600 |
| | Y450-6(6kV) | 800-900 | | | | | | | 1780 | 1120 | 1620 | 800 | 910 | 450 | 935 | 2080 | | | 3850 |

DMC600-540 E Curve n=960r/min

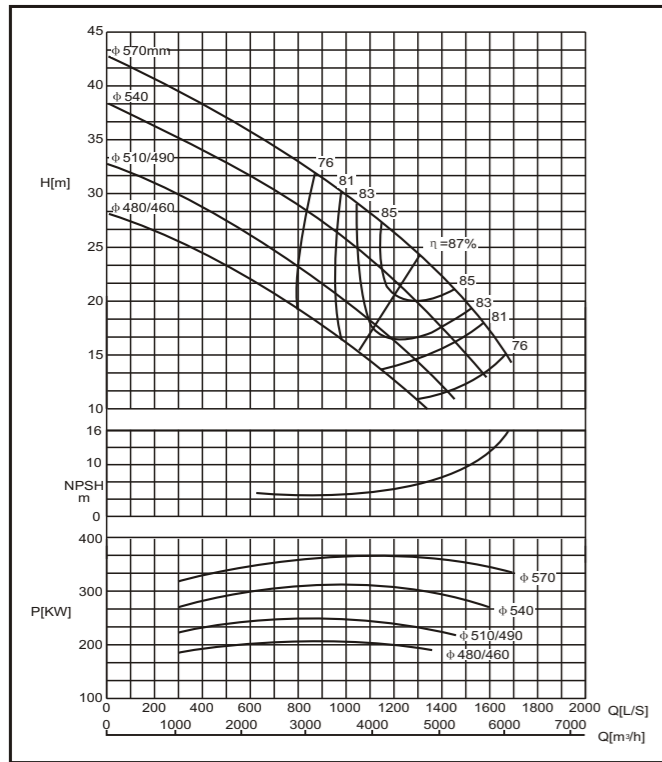

DMC600-540 F Curve n=960r/min

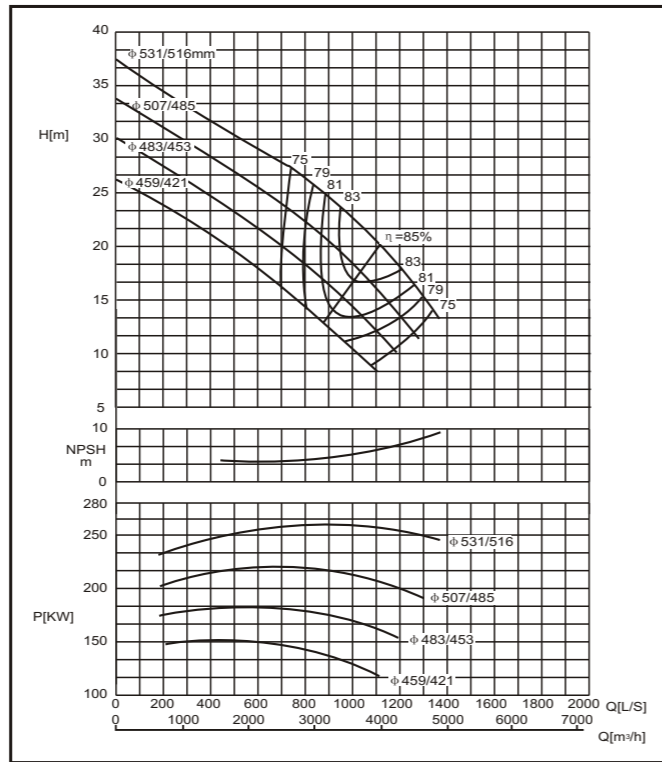

DMC卧式泵安装尺寸图 Installing dimensions of DMC pumps

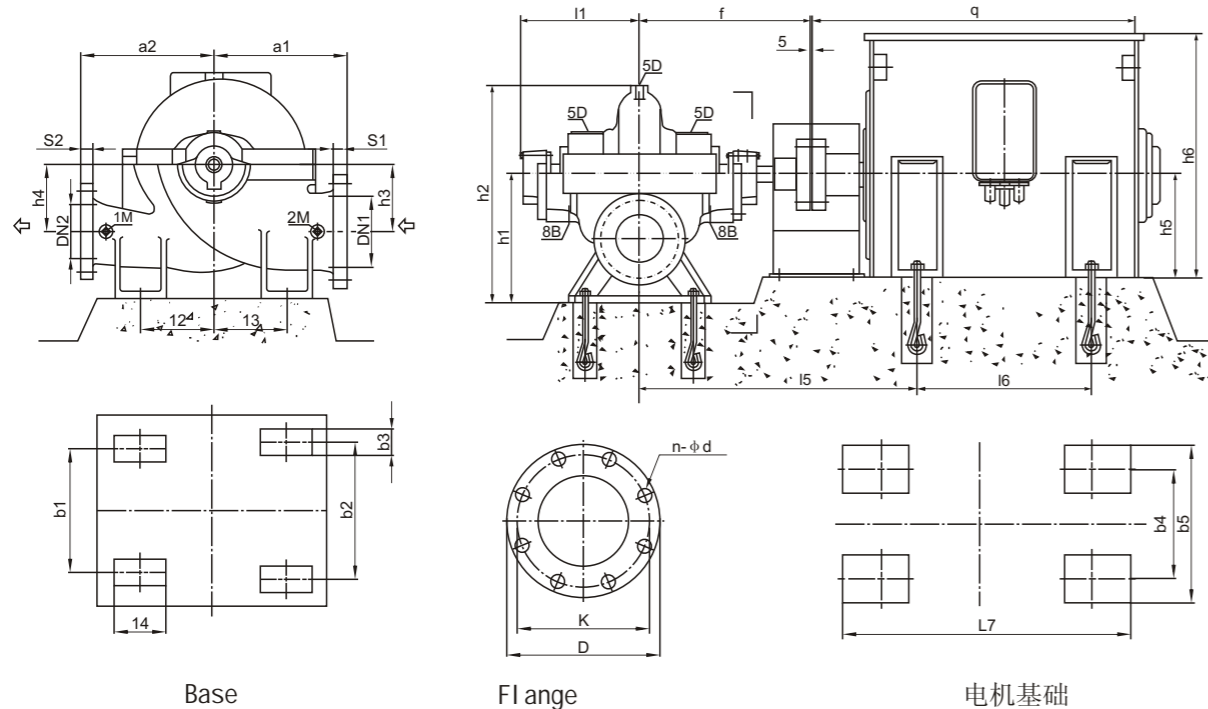

连接尺寸 connection dimensions:

- 1M、2M 压力表 Rp1/2 1M、2M pressure gauge Rp1/2
- 5D 排气孔 Rp1/2 5D air vent Rp1/2
- 6B 排液孔 Rp3/4 6B drain plug Rp3/4
- 8B 漏液排出孔 Rp3/4 8B drain plug Rp3/4

DMC600-620 E Curve n=960r/min

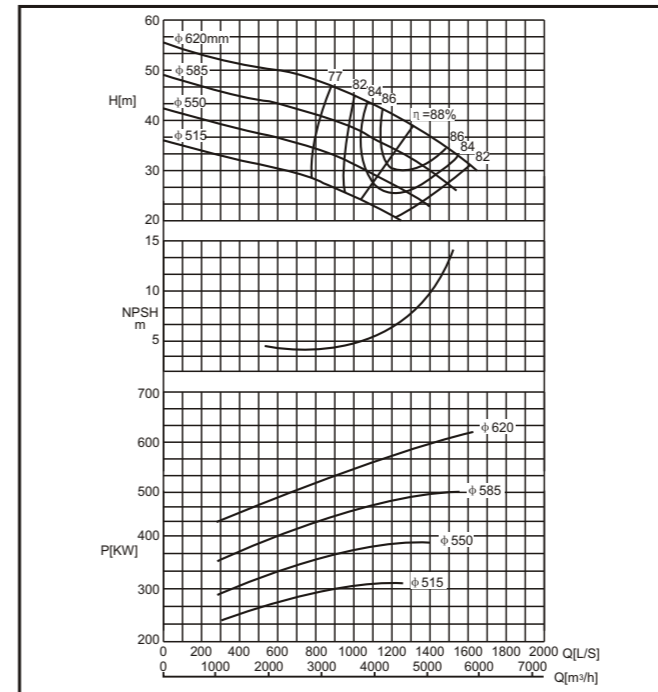

DMC600-620 F Curve n=960r/min

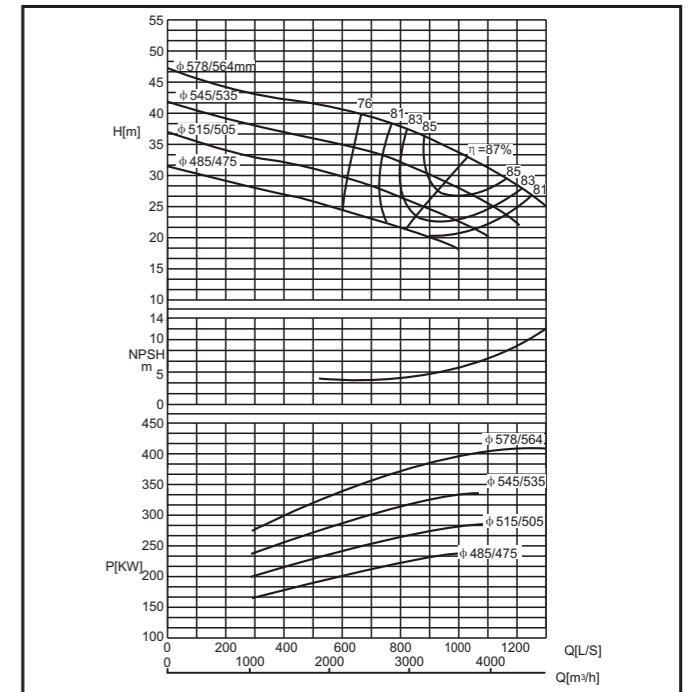

参数表 Standard performance

| 泵型号 Type | 流量 Capacity Q | | 扬程 Head m | 转速 Speed r/min | 轴功率 Shaft power kW | 效率 eff η % | 有效汽 蚀余量 NPSHa m | 电机功率 Motor power kW | 叶轮参 考直径 D(mm) |
|-----------------|---------------------|------|-----------------|----------------------|-----------------------------|------------------|--------------------------|------------------------------|---------------------|
| | m³/h | l/s | | | | | | | |
| DMC 600-540E | 2810 | 781 | 33.3 | 960 | 344 | 74 | 5.9 | 400 | 570 |
| | 4680 | 1300 | 24.2 | | 354 | 87 | | | |
| | 6080 | 1689 | 14.3 | | 316 | 75 | | | |
| | 2660 | 739 | 33.7 | | 334 | 73 | | | |
| | 4430 | 1231 | 21.5 | | 302 | 86 | | | |
| | 5690 | 1581 | 13 | | 272 | 74 | | | |
| DMC 600-540F | 2430 | 675 | 25 | 960 | 230 | 72 | 4.5 | 250 | 510 |
| | 4040 | 1122 | 17.8 | | 230 | 85 | | | |
| | 5220 | 1450 | 11 | | 214 | 73 | | | |
| | 2270 | 631 | 21.5 | | 187 | 71 | | | |
| | 3780 | 1050 | 15.5 | | 190 | 84 | | | |
| | 4850 | 1347 | 10 | | 184 | 72 | | | |
| DMC 600-620E | 2370 | 658 | 28.3 | 960 | 250 | 73 | 6.0 | 315 | 531 |
| | 3960 | 1100 | 20.3 | | 257 | 85 | | | |
| | 4900 | 1361 | 13.3 | | 240 | 74 | | | |
| | 2250 | 625 | 28.8 | | 245 | 72 | | | |
| | 3750 | 1042 | 18 | | 219 | 84 | | | |
| | 4600 | 1278 | 11.5 | | 197 | 73 | | | |
| DMC 600-620F | 2070 | 575 | 22.3 | 960 | 177 | 71 | 5.0 | 200 | 483 |
| | 3450 | 958 | 15.5 | | 175 | 83 | | | |
| | 4250 | 1181 | 10 | | 158 | 73 | | | |
| | 1890 | 525 | 19.3 | | 142 | 70 | | | |
| | 3150 | 875 | 13 | | 136 | 82 | | | |
| | 4000 | 1111 | 8.5 | | 128 | 72 | | | |

参数表 Standard performance

| 泵型号 Type | 流量 Capacity Q | | 扬程 Head m | 转速 Speed r/min | 轴功率 Shaft power kW | 效率 eff η % | 有效汽 蚀余量 NPSHa m | 电机功率 Motor power kW | 叶轮参 考直径 D(mm) |
|-----------------|---------------------|------|-----------------|----------------------|-----------------------------|------------------|--------------------------|------------------------------|---------------------|
| | m³/h | l/s | | | | | | | |
| DMC 600-620E | 2830 | 786 | 48 | 960 | 493 | 75 | 7.8 | 630 | 620 |
| | 4720 | 1311 | 39 | | 569 | 88 | | | |
| | 5940 | 1650 | 30 | | 599 | 81 | | | |
| | 2650 | 736 | 42 | | 404 | 75 | | | |
| | 4420 | 1228 | 34 | | 470 | 87 | | | |
| | 5580 | 1550 | 26 | | 494 | 80 | | | |
| DMC 600-620F | 2450 | 681 | 36 | 960 | 324 | 74 | 6.0 | 450 | 550 |
| | 4080 | 1133 | 29 | | 375 | 86 | | | |
| | 5040 | 1400 | 23.2 | | 398 | 80 | | | |
| | 2250 | 625 | 30 | | 252 | 73 | | | |
| | 3750 | 1042 | 24.8 | | 298 | 85 | | | |
| | 4500 | 1250 | 20 | | 310 | 79 | | | |
| DMC 600-620E | 2215 | 615 | 40.5 | 960 | 326 | 75 | 6.0 | 450 | 578 |
| | 3690 | 1025 | 33 | | 381 | 87 | | | |
| | 4680 | 1300 | 25 | | 398 | 80 | | | |
| | 2060 | 572 | 35 | | 265 | 74 | | | |
| | 3440 | 956 | 29 | | 316 | 86 | | | |
| | 4400 | 1222 | 22 | | 334 | 79 | | | |
| DMC 600-620F | 1900 | 528 | 30 | 960 | 213 | 73 | 4.7 | 280 | 515 |
| | 3170 | 881 | 25 | | 254 | 85 | | | |
| | 3980 | 1106 | 20 | | 278 | 78 | | | |
| | 1770 | 492 | 26 | | 174 | 72 | | | |
| | 2950 | 819 | 21.5 | | 205 | 84 | | | |
| | 3600 | 1000 | 18 | | 229 | 77 | | | |

主要外型尺寸 pump outline size

| 泵型号 type | 法兰尺寸 flange size | | | | | | | | | | 泵尺寸 pump size | | | | | | | 泵重量 W.T kg | |
|-------------|-------------------|----|-----|-----|--------|--------------------|----|-----|-----|--------|---------------|------|------|------|-----|-----|-----|------------------|------|
| | 进口法兰 inlet flange | | | | | 出口法兰 outlet flange | | | | | | | | | | | | | |
| | DN1 | S1 | K | D | n-φd | DN2 | S2 | K | D | n-φd | a1 | a2 | h1 | h2 | h3 | h4 | l1 | | f |
| 600-540 | 700 | 54 | 840 | 915 | 24-φ41 | 600 | 54 | 770 | 845 | 20-φ41 | 1100 | 900 | 1100 | 1850 | 610 | 610 | 885 | 1080 | 2725 |
| 600-620 | 700 | 54 | 840 | 915 | 24-φ41 | 600 | 54 | 770 | 845 | 20-φ41 | 1000 | 1000 | 1050 | 1700 | 545 | 545 | 840 | 1060 | 2961 |

连接尺寸 connection size

| 泵型号 type | 电机 Motor | | 12 | 13 | 14 | b1 | b2 | b3 | 15 | 16 | 17 | b4 | b5 | h5 | h6 | q | 地脚螺栓 anchor | | |
|-------------|-------------|---------|-----|-----|-----|-----|------|------|------|------|------|-----|-----|-----|------|------|-------------|----------|---------------------|
| | 型号Type | 功率(kW) | | | | | | | | | | | | | | | 泵 pump | 电机 motor | 电机最大重量 motor W.T |
| 600-540 | Y400-6(6kV) | 355-400 | | | | | | | 1630 | 1000 | 1510 | 710 | 810 | 400 | 835 | 1940 | M36×600 | M30×600 | 2620 |
| | Y355-6(6kV) | 315 | | | | | | 1610 | 1000 | 1420 | 630 | 770 | 355 | 780 | 1820 | | | | |
| | Y355L1-6 | 280 | 550 | 650 | 300 | 800 | 1100 | 150 | 1509 | 630 | 808 | 610 | 730 | 355 | 860 | 1545 | | | |
| | Y355M-6 | 220-250 | | | | | | | 1509 | 560 | 808 | 610 | 730 | 355 | 860 | 1545 | | | |
| | Y315L-6 | 160-200 | | | | | | | 1471 | 508 | 720 | 508 | 640 | 315 | 865 | 1340 | | | |
| 600-620 | Y450-6(6kV) | 630 | | | | | | | 1630 | 1120 | 1620 | 800 | 910 | 450 | 935 | 2080 | M36×600 | M30×600 | 3850 |
| | Y400-6(6kV) | 355-560 | 650 | 650 | 300 | 800 | 1100 | 150 | 1610 | 1000 | 1510 | 710 | 810 | 400 | 835 | 1940 | | | |
| | Y355-6(6kV) | 250-315 | | | | | | | 1590 | 900 | 1420 | 630 | 770 | 355 | 780 | 1820 | | | |

DMC600-710 E Curve n=960r/min

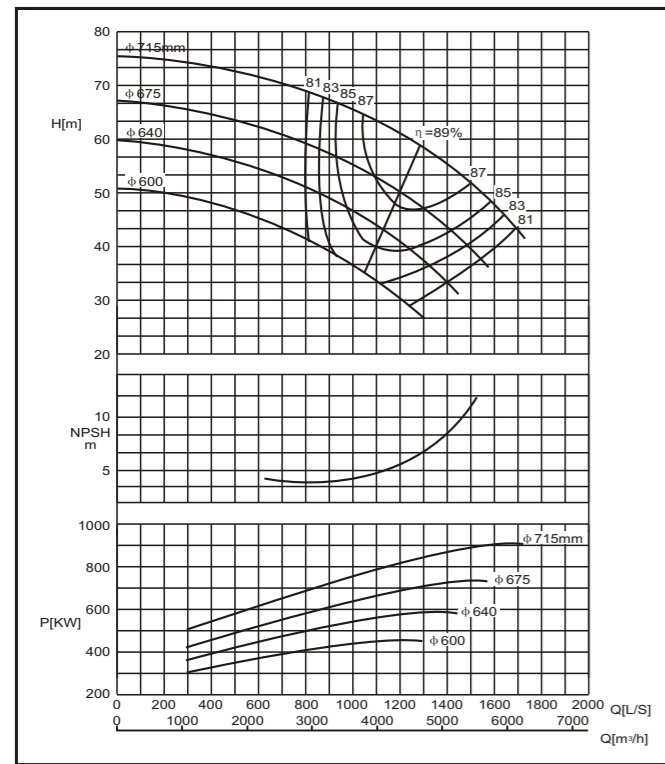

DMC600-710 F Curve n=960r/min

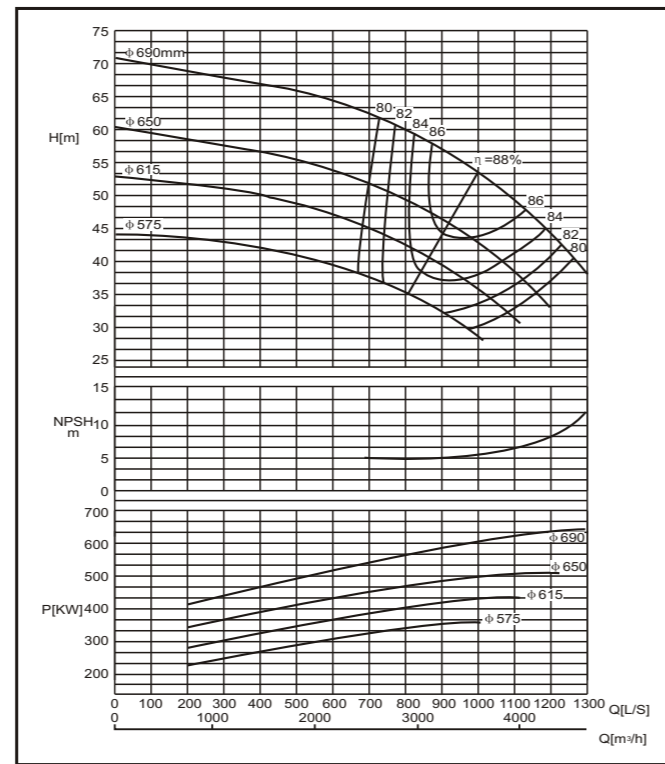

DMC600-830 E Curve n=960r/min

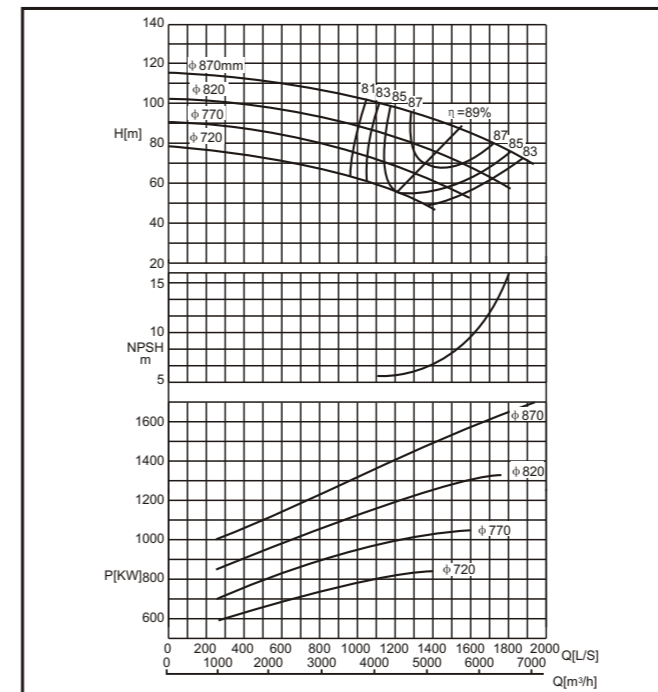

DMC600-830 F Curve n=960r/min

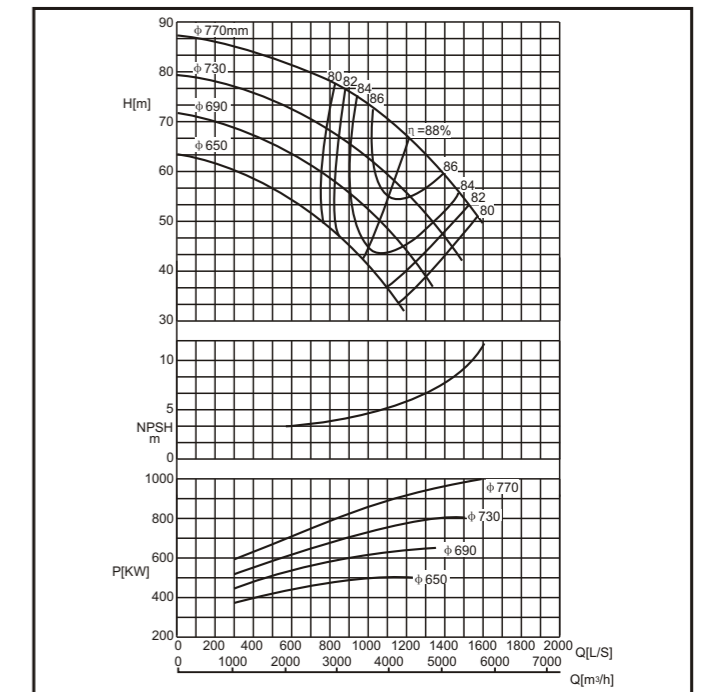

DMC卧式泵安装尺寸图 Installing dimensions of DMC pumps

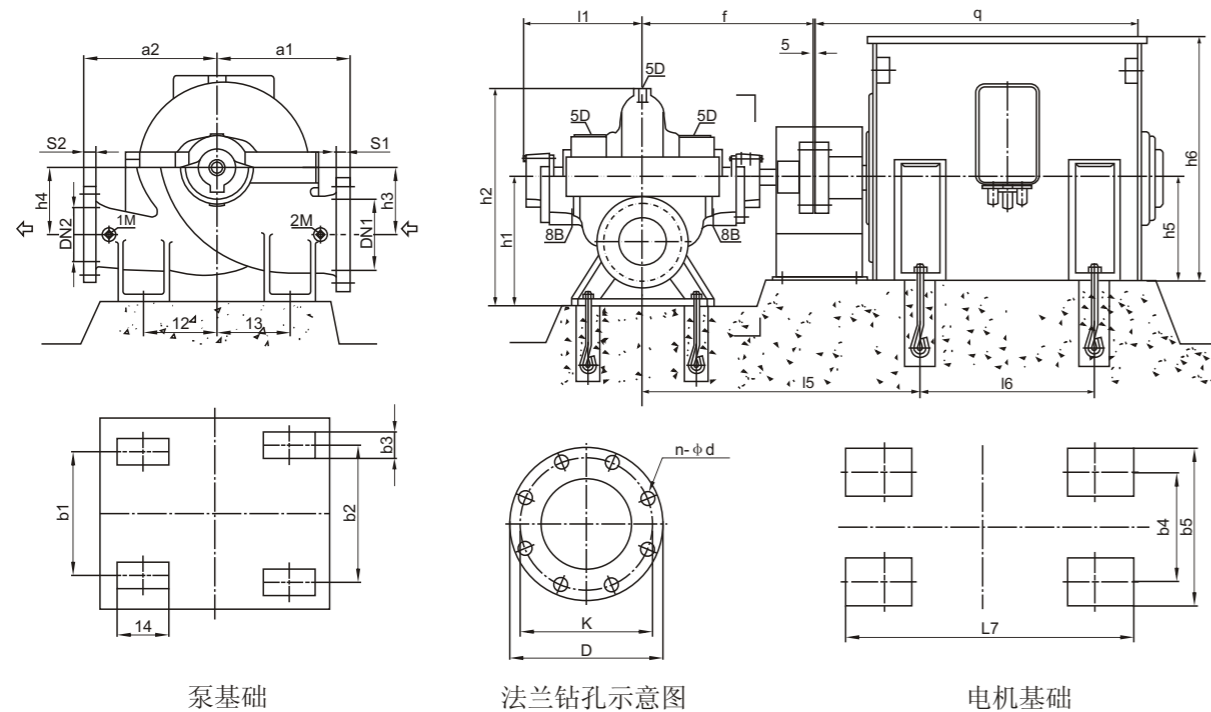

连接尺寸 connection dimensions:

- 1M、2M 压力表 Rp1/2 1M、2M pressure gauge Rp1/2
- 5D 排气孔 Rp1/2 5D air vent Rp1/2
- 6B 排液孔 Rp3/4 6B drain plug Rp3/4
- 8B 漏液排出孔 Rp3/4 8B drain plug Rp3/4

参数表 Standard performance

| 泵型号 Type | 流量 Capacity Q | | 扬程 Head m | 转速 Speed r/min | 轴功率 Shaft power kW | 效率 eff % | 有效汽 蚀余量 NPSHa m | 电机功率 Motor power kW | 叶轮参 考直径 D(mm) |
|-----------------|---------------------|------|-----------------|----------------------|-----------------------------|----------------|--------------------------|------------------------------|---------------------|
| | m³/h | l/s | | | | | | | |
| DMC 600-710E | 2780 | 772 | 69 | 960 | 653 | 80 | 6.5 | 900 | 715 |
| | 4630 | 1286 | 58.5 | | 828 | 89 | | | |
| | 6050 | 1680 | 43.5 | | 896 | 80 | | | |
| | 2600 | 722 | 60.5 | | 542 | 79 | | | |
| | 4320 | 1200 | 50 | | 668 | 88 | | | |
| | 5620 | 1561 | 36 | | 697 | 79 | | | |
| DMC 600-710F | 2430 | 675 | 53 | 960 | 449 | 78 | 5.0 | 630 | 640 |
| | 4050 | 1125 | 43 | | 545 | 87 | | | |
| | 5220 | 1450 | 31 | | 565 | 78 | | | |
| | 2270 | 630 | 45 | | 361 | 77 | | | |
| | 3780 | 1050 | 35 | | 419 | 86 | | | |
| | 4680 | 1300 | 27 | | 447 | 77 | | | |
| DMC 600-830E | 2160 | 600 | 64.5 | 960 | 486 | 78 | 5.2 | 710 | 690 |
| | 3600 | 1000 | 54 | | 601 | 89 | | | |
| | 4680 | 1300 | 38 | | 621 | 78 | | | |
| | 1990 | 553 | 54.6 | | 384 | 77 | | | |
| | 3310 | 919 | 45.8 | | 474 | 87 | | | |
| | 4300 | 1194 | 33 | | 502 | 77 | | | |
| DMC 600-830F | 1880 | 522 | 48.2 | 960 | 325 | 76 | 5.0 | 450 | 615 |
| | 3130 | 869 | 40.5 | | 401 | 86 | | | |
| | 4060 | 1128 | 30.5 | | 444 | 76 | | | |
| | 1740 | 483 | 41 | | 259 | 75 | | | |
| | 2900 | 806 | 35 | | 325 | 85 | | | |
| | 3670 | 1019 | 28 | | 373 | 75 | | | |

参数表 Standard performance

| 泵型号 Type | 流量 Capacity Q | | 扬程 Head m | 转速 Speed r/min | 轴功率 Shaft power kW | 效率 eff % | 有效汽 蚀余量 NPSHa m | 电机功率 Motor power kW | 叶轮参 考直径 D(mm) |
|-----------------|---------------------|------|-----------------|----------------------|-----------------------------|----------------|--------------------------|------------------------------|---------------------|
| | m³/h | l/s | | | | | | | |
| DMC 600-830E | 3300 | 917 | 105 | 960 | 1194 | 79 | 8.5 | 1600 | 870 |
| | 5500 | 1528 | 87.5 | | 1472 | 89 | | | |
| | 6950 | 1931 | 70 | | 1615 | 82 | | | |
| | 3060 | 850 | 93 | | 993 | 78 | | | |
| | 5110 | 1419 | 76 | | 1201 | 88 | | | |
| | 6480 | 1800 | 57 | | 1183 | 85 | | | |
| DMC 600-830F | 2800 | 778 | 82 | 960 | 812 | 77 | 6.2 | 1120 | 770 |
| | 4680 | 1300 | 62 | | 908 | 87 | | | |
| | 5800 | 1611 | 57 | | 1203 | 86 | | | |
| | 2610 | 725 | 70 | | 654 | 76 | | | |
| | 4350 | 1208 | 56 | | 762 | 87 | | | |
| | 5040 | 1400 | 47 | | 786 | 82 | | | |
| DMC 600-830F | 2600 | 722 | 79 | 960 | 717 | 78 | 6.0 | 1000 | 770 |
| | 4320 | 1200 | 65.2 | | 895 | 88 | | | |
| | 5620 | 1561 | 51 | | 919 | 80 | | | |
| | 1990 | 553 | 54.6 | | 683 | 71.4 | | | |
| | 3310 | 919 | 45.8 | | 744 | 87 | | | |
| | 4300 | 1194 | 33 | | 770 | 79 | | | |
| DMC 600-830F | 2300 | 639 | 62.8 | 960 | 504 | 78 | 5.0 | 710 | 690 |
| | 3820 | 1061 | 50 | | 598 | 87 | | | |
| | 4950 | 1375 | 48 | | 779 | 83 | | | |
| | 2080 | 578 | 55 | | 404 | 77 | | | |
| | 3460 | 961 | 42.5 | | 465 | 86 | | | |
| | 4250 | 1181 | 32 | | 469 | 79 | | | |

主要外型尺寸 pump outline size

| 泵型号 type | 法兰尺寸 flange size | | | | | | | | | | 泵尺寸 pump size | | | | | | 泵重量 W.T kg | | |
|-------------|-------------------|----|-----|-----|--------|--------------------|----|-----|-----|--------|---------------|------|------|------|-----|-----|------------------|------|------|
| | 进口法兰 inlet flange | | | | | 出口法兰 outlet flange | | | | | a1 | a2 | h1 | h2 | h3 | h4 | | l1 | f |
| | DN1 | S1 | K | D | n-φd | DN2 | S2 | K | D | n-φd | | | | | | | | | |
| 600-710 | 700 | 54 | 845 | 910 | 24-φ41 | 600 | 54 | 770 | 845 | 20-φ41 | 1000 | 1100 | 1050 | 1700 | 545 | 545 | 930 | 1160 | 3427 |
| 600-830 | 700 | 54 | 845 | 910 | 24-φ41 | 600 | 54 | 770 | 845 | 20-φ41 | 1100 | 1200 | 1100 | 1860 | 580 | 580 | 1000 | 1275 | 4700 |

连接尺寸 connection size

| 泵型号 type | 电机 Motor | | 12 | 13 | 14 | b1 | b2 | b3 | 15 | 16 | 17 | b4 | b5 | h5 | h6 | q | 地脚螺栓 anchor | | 电机最大重量 motor W.T |
|-------------|-------------|-----------|------|------|------|-----|------|-----|------|------|------|------|------|-----|------|------|-------------|----------|---------------------|
| | 型号 Type | 功率(kW) | | | | | | | | | | | | | | | 泵 pump | 电机 motor | |
| 600-710 | Y450-6(6kV) | 630-900 | 650 | 650 | 300 | 900 | 1200 | 150 | 1730 | 1120 | 1620 | 800 | 910 | 450 | 925 | 2080 | M42×800 | M30×600 | 3850 |
| | Y400-6(6kV) | 400-560 | 1710 | 1000 | 1510 | 710 | 810 | 400 | 835 | 1940 | 5680 | | | | | | | | |
| 600-830 | Y560-6(6kV) | 1600-1800 | 750 | 650 | 300 | 900 | 1200 | 150 | 2030 | 1400 | 1880 | 1000 | 1130 | 560 | 1160 | 2715 | M42×800 | M36×600 | 4600 |
| | Y500-6(6kV) | 1000-1400 | | | | | | | 2005 | 1250 | 1730 | 900 | 1010 | 500 | 1040 | 2550 | | | 3850 |
| | Y450-6(6kV) | 630-900 | | | | | | | 1845 | 1120 | 1620 | 800 | 910 | 450 | 935 | 2080 | | | 2620 |
| | Y400-6(6kV) | 560 | | | | | | | 1825 | 1000 | 1510 | 710 | 810 | 400 | 835 | 1940 | | | |

DMC700-590 E Curve n=960r/min

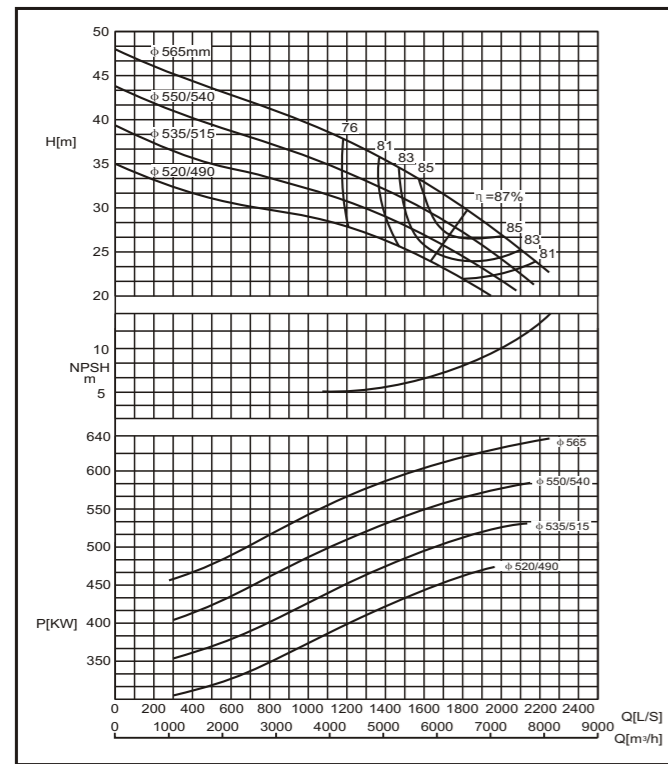

DMC700-590 F Curve n=960r/min

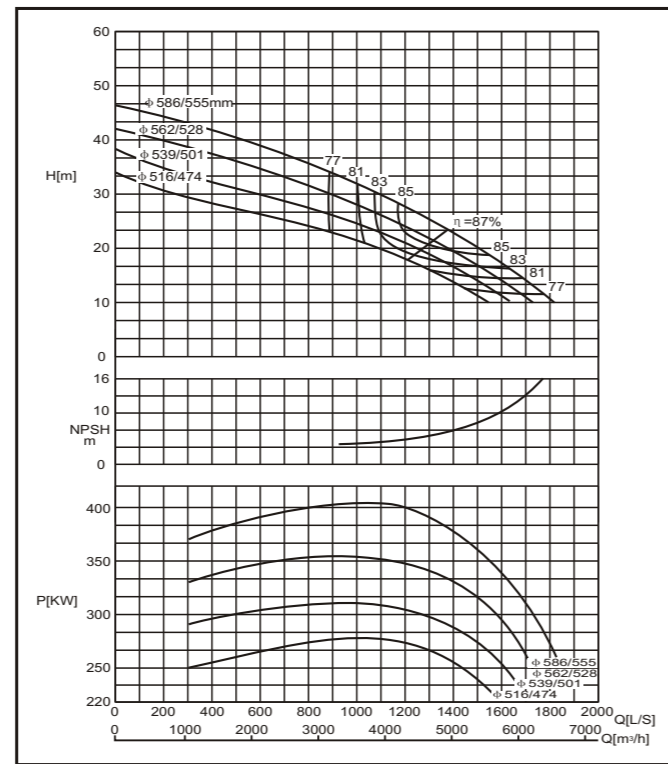

DMC卧式泵安装尺寸图 Installing dimensions of DMC pumps

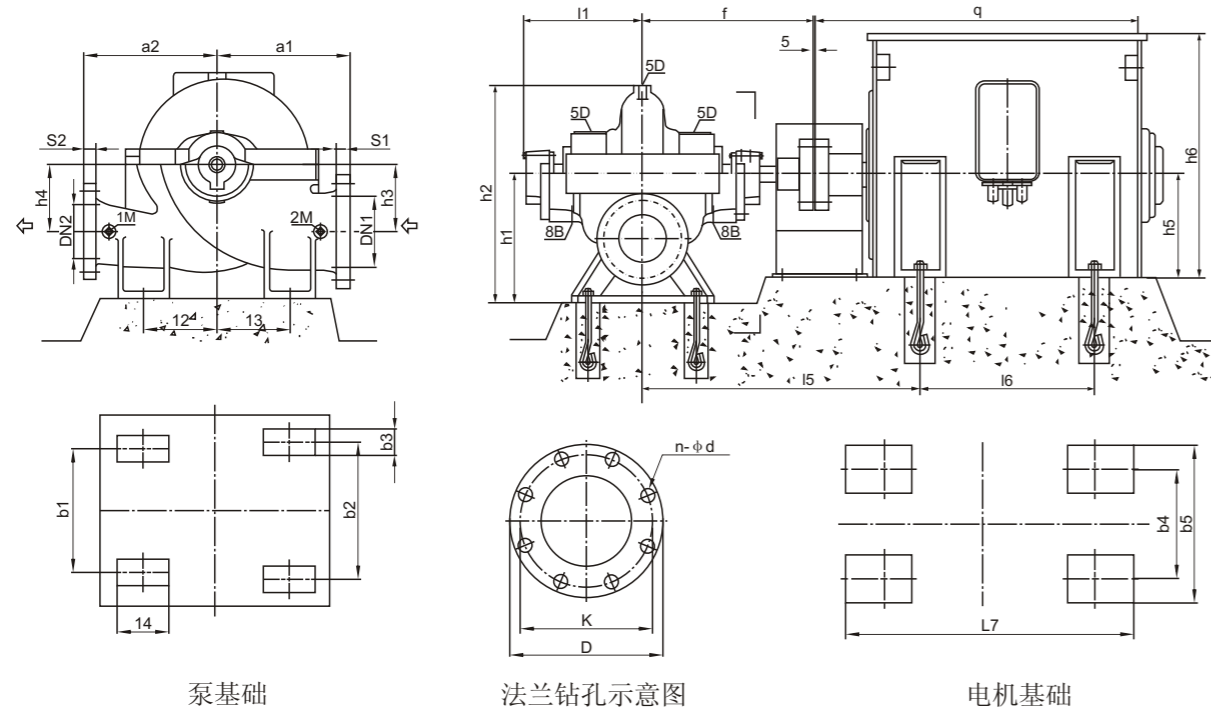

连接尺寸 connection dimensions:

- 1M、2M 压力表 Rp1/2 1M、2M pressure gauge Rp1/2
- 5D 排气孔 Rp1/2 5D air vent Rp1/2
- 6B 排液孔 Rp3/4 6B drain plug Rp3/4
- 8B 漏液排出孔 Rp3/4 8B drain plug Rp3/4

DMC700-710 E Curve n=960r/min

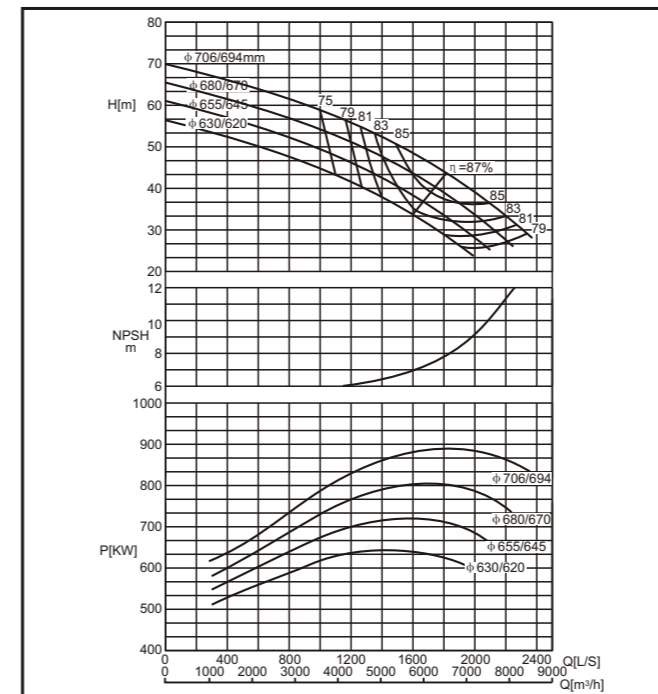

DMC700-710 F Curve n=960r/min

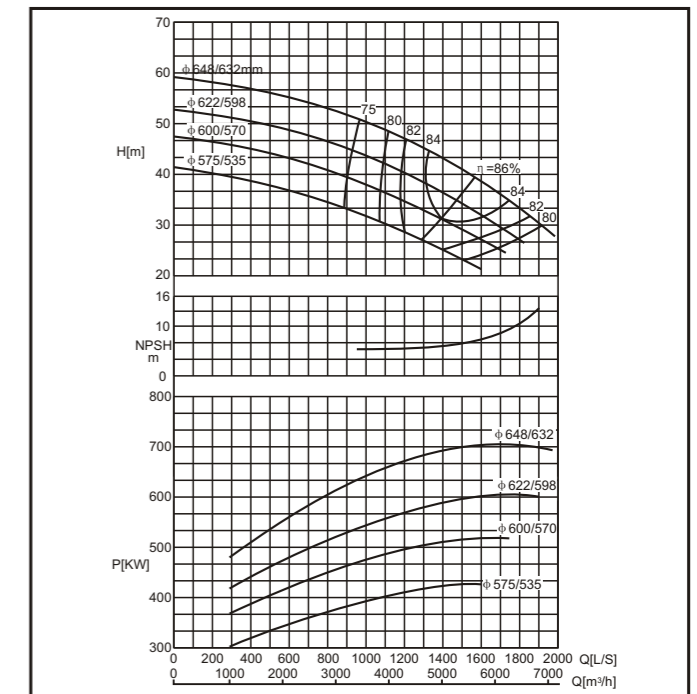

参数表 Standard performance

| 泵型号 Type | 流量 Capacity Q | | 扬程 Head m | 转速 Speed r/min | 轴功率 Shaft power kW | 效率 eff % | 有效汽 蚀余量 NPSHa m | 电机功率 Motor power kW | 叶轮参 考直径 D(mm) |
|-----------------|---------------------|------|-----------------|----------------------|-----------------------------|----------------|--------------------------|------------------------------|---------------------|
| | m³/h | l/s | | | | | | | |
| DMC 700-590E | 3900 | 1083 | 38.8 | 960 | 549 | 75 | 8.0 | 710 | 565 |
| | 6480 | 1800 | 30 | | | | | | |
| | 8060 | 2239 | 22.7 | | | | | | |
| | 3780 | 1050 | 35.5 | | | | | | |
| | 6300 | 1750 | 28 | | | | | | |
| | 7800 | 2167 | 21.2 | | | | | | |
| DMC 700-590F | 3630 | 1008 | 32 | 960 | 427 | 74 | 7.0 | 560 | 535 |
| | 6050 | 1681 | 25 | | | | | | |
| | 7450 | 2069 | 20.9 | | | | | | |
| | 3500 | 972 | 29 | | | | | | |
| | 5870 | 1631 | 24 | | | | | | |
| | 7000 | 1944 | 20.2 | | | | | | |
| DMC 700-710E | 2980 | 828 | 35.2 | 960 | 376 | 76 | 6.0 | 400 | 586 |
| | 4970 | 1381 | 23.7 | | | | | | |
| | 6500 | 1806 | 10.2 | | | | | | |
| | 2850 | 792 | 36 | | | | | | |
| | 4750 | 1319 | 21.6 | | | | | | |
| | 6150 | 1708 | 10.5 | | | | | | |
| DMC 700-710F | 2750 | 764 | 28 | 960 | 276 | 76 | 5.0 | 315 | 539 |
| | 4540 | 1261 | 20 | | | | | | |
| | 5900 | 1639 | 10.5 | | | | | | |
| | 2610 | 725 | 25 | | | | | | |
| | 4350 | 1208 | 18 | | | | | | |
| | 5550 | 1542 | 10 | | | | | | |

参数表 Standard performance

| 泵型号 Type | 流量 Capacity Q | | 扬程 Head m | 转速 Speed r/min | 轴功率 Shaft power kW | 效率 eff % | 有效汽 蚀余量 NPSHa m | 电机功率 Motor power kW | 叶轮参 考直径 D(mm) |
|-----------------|---------------------|------|-----------------|----------------------|-----------------------------|----------------|--------------------------|------------------------------|---------------------|
| | m³/h | l/s | | | | | | | |
| DMC 700-710E | 3650 | 1014 | 58.5 | 960 | 775 | 75 | 8.0 | 1000 | 706 |
| | 6500 | 1806 | 44 | | | | | | |
| | 8460 | 2350 | 28 | | | | | | |
| | 3750 | 1042 | 53.8 | | | | | | |
| | 6270 | 1742 | 40.2 | | | | | | |
| | 8060 | 2239 | 26 | | | | | | |
| DMC 700-710F | 3570 | 992 | 49.5 | 960 | 650 | 74 | 7.3 | 800 | 655 |
| | 6870 | 1906 | 37 | | | | | | |
| | 7560 | 2100 | 25.5 | | | | | | |
| | 3450 | 958 | 45 | | | | | | |
| | 5740 | 1594 | 34 | | | | | | |
| | 7100 | 1972 | 23.8 | | | | | | |
| DMC 700-710E | 3360 | 933 | 51.5 | 960 | 637 | 74 | 7.0 | 800 | 648 |
| | 5600 | 1558 | 35.5 | | | | | | |
| | 7280 | 2022 | 26 | | | | | | |
| | 3180 | 883 | 45.5 | | | | | | |
| | 5300 | 1472 | 35 | | | | | | |
| | 6550 | 1819 | 26.5 | | | | | | |
| DMC 700-710F | 3020 | 839 | 41 | 960 | 455 | 74 | 6.0 | 560 | 600 |
| | 5040 | 1400 | 31.5 | | | | | | |
| | 6200 | 1722 | 24.5 | | | | | | |
| | 2780 | 772 | 35.8 | | | | | | |
| | 4630 | 1288 | 27.5 | | | | | | |
| | 5760 | 1600 | 21 | | | | | | |

主要外型尺寸 pump outline size

| 泵型号 type | 法兰尺寸 flange size | | | | | | | | | | 泵尺寸 pump size | | | | | | 泵重量 W.T kg | | |
|-------------|-------------------|----|-----|------|--------|--------------------|----|-----|-----|--------|---------------|------|------|------|-----|-----|------------------|------|------|
| | 进口法兰 inlet flange | | | | | 出口法兰 outlet flange | | | | | a1 | a2 | h1 | h2 | h3 | h4 | | l1 | f |
| | DN1 | S1 | K | D | n-φd | DN2 | S2 | K | D | n-φd | | | | | | | | | |
| 700-590 | 800 | 54 | 950 | 1025 | 24-φ41 | 700 | 54 | 840 | 915 | 24-φ41 | 1300 | 800 | 1150 | 1870 | 600 | 600 | 1090 | 1300 | 4043 |
| 700-710 | 800 | 54 | 950 | 1025 | 24-φ41 | 700 | 54 | 840 | 915 | 24-φ41 | 1200 | 1150 | 1170 | 1920 | 620 | 620 | 1130 | 1360 | 5329 |

连接尺寸 connection size

| 泵型号 type | 电机 Motor | | 12 | 13 | 14 | b1 | b2 | b3 | 15 | 16 | 17 | b4 | b5 | h5 | h6 | q | 地脚螺栓 anchor | | 电机最大重量 motor W.T |
|-------------|-------------|---------|-----|-----|-----|-----|------|-----|------|------|------|-----|------|-----|------|------|-------------|----------|---------------------|
| | 型号 Type | 功率 (kW) | | | | | | | | | | | | | | | 泵 pump | 电机 motor | |
| 700-590 | Y450-6(6kV) | 630-710 | 425 | 725 | 350 | 790 | 1090 | 150 | 1870 | 1120 | 1620 | 800 | 910 | 450 | 935 | 2080 | M36×600 | M30×600 | 3850 |
| | Y400-6(6kV) | 355-560 | | | | | | | 1850 | 1000 | 1510 | 710 | 810 | 400 | 835 | 1940 | | M24×500 | 2160 |
| | Y355-6(6kV) | 280-315 | | | | | | | 1830 | 900 | 1420 | 630 | 770 | 355 | 780 | 1820 | | M36×600 | 4600 |
| 700-710 | Y500-6(6kV) | 1000 | 725 | 725 | 350 | 790 | 1090 | 150 | 2090 | 1250 | 1730 | 900 | 1010 | 500 | 1040 | 2550 | M42×800 | M36×600 | 3850 |
| | Y450-6(6kV) | 630-900 | | | | | | | 1930 | 1120 | 1620 | 800 | 910 | 450 | 935 | 2080 | | M30×600 | 2620 |
| | Y400-6(6kV) | 500-560 | | | | | | | 1910 | 1000 | 1510 | 710 | 810 | 400 | 835 | 1940 | | | |

DMC700-820E Curve n=960r/min

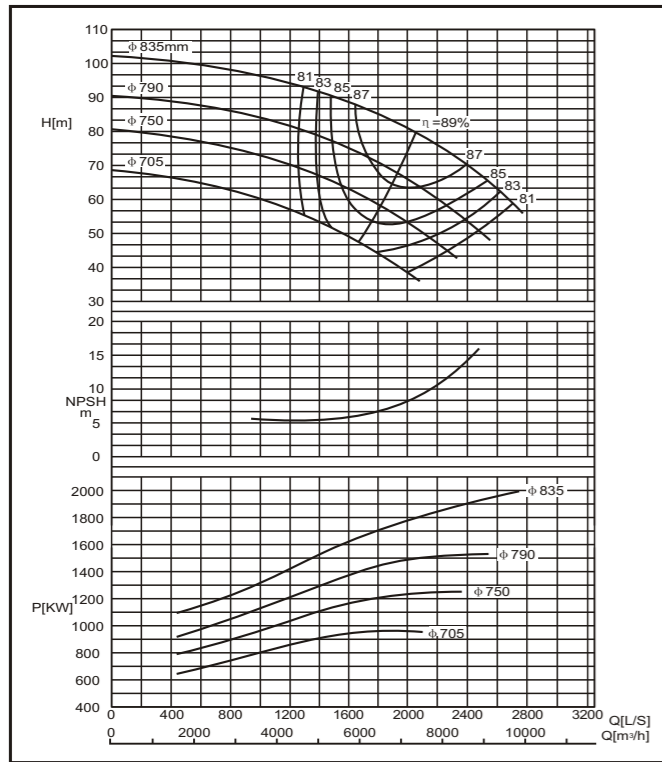

DMC700-820F Curve n=960r/min

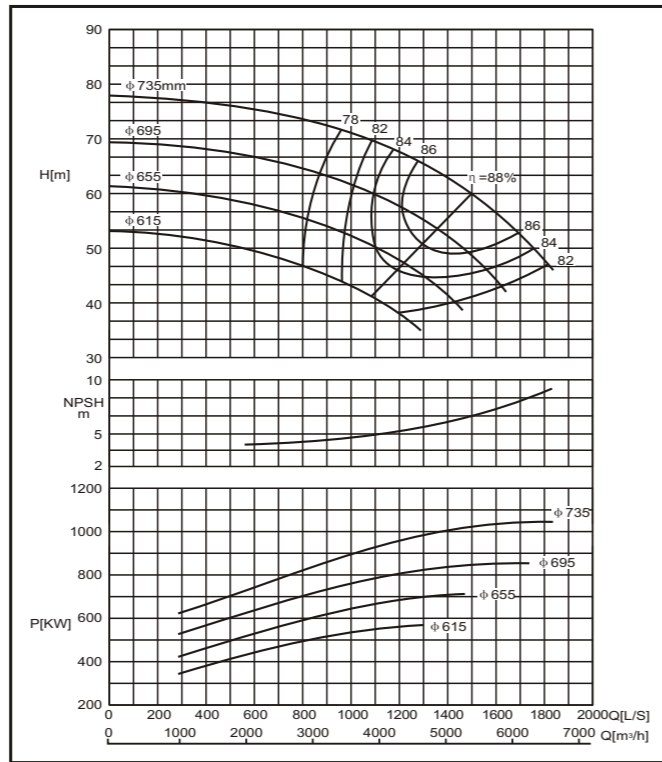

DMC卧式泵安装尺寸图 Installing dimensions of DMC pumps

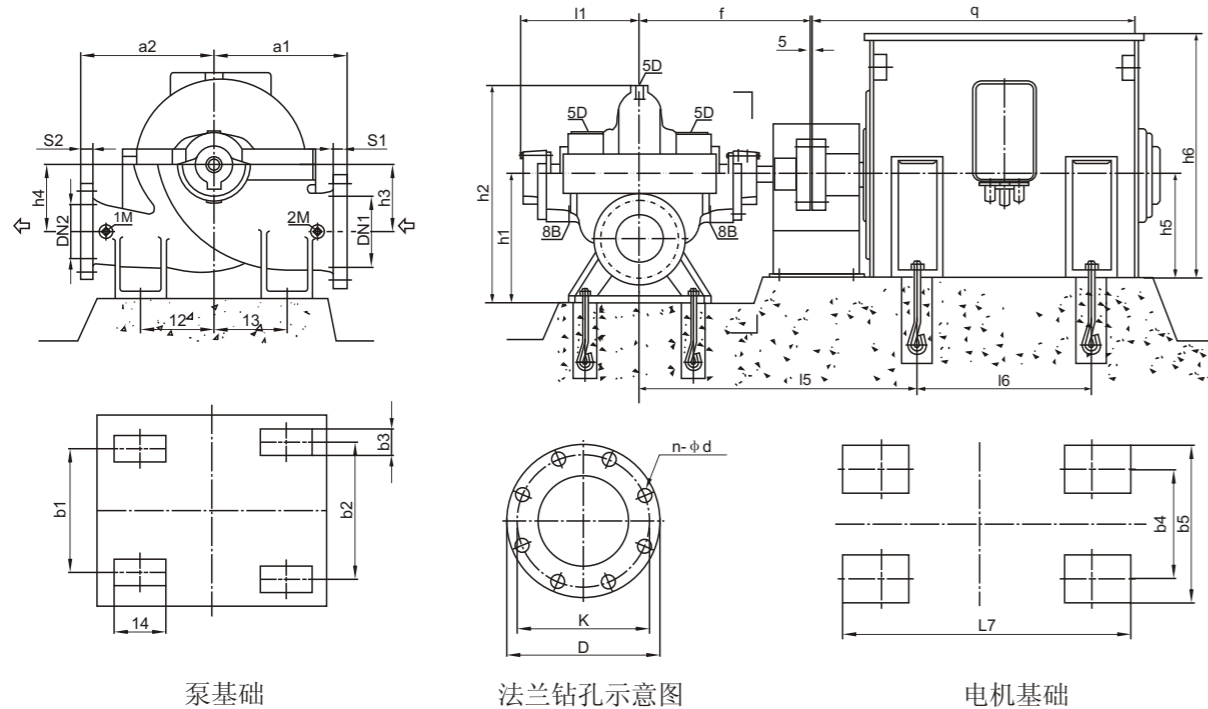

连接尺寸 connection dimensions:

- 1M、2M 压力表 Rp1/2
- 1M、2M pressure gauge Rp1/2
- 5D 排气孔 Rp1/2
- 5D air vent Rp1/2
- 6B 排液孔 Rp3/4
- 6B drain plug Rp3/4
- 8B 漏液排出孔 Rp3/4
- 8B drain plug Rp3/4

DMC800-740 E Curve n=725r/min

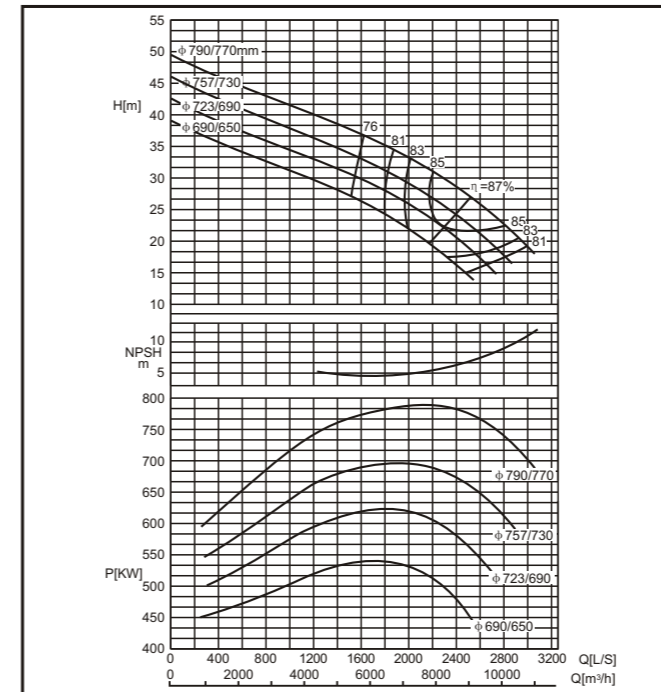

DMC800-740 F Curve n=725r/min

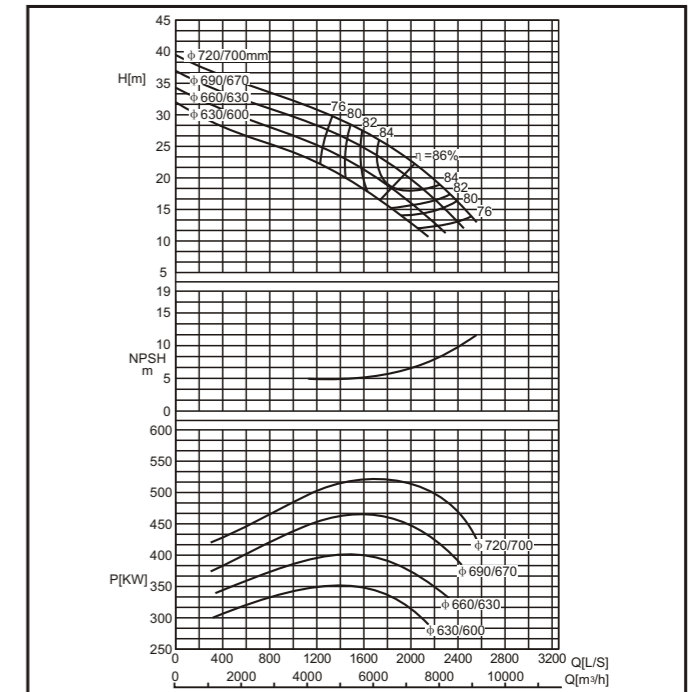

参数表 Standard performance

| 泵型号 Type | 流量 Capacity Q | | 扬程 Head m | 转速 Speed r/min | 轴功率 Shaft power kW | 效率 eff % | 有效汽 蚀余量 NPSHa m | 电机功率 Motor power kW | 叶轮参 考直径 D(mm) |
|-----------------|---------------------|------|-----------------|----------------------|-----------------------------|----------------|--------------------------|------------------------------|---------------------|
| | m³/h | l/s | | | | | | | |
| DMC 700-820E | 4430 | 1231 | 92 | 960 | 1387 | 80 | 8.8 | 2000 | 835 |
| | 7380 | 2050 | 80 | | 1806 | 89 | | | |
| | 9600 | 2667 | 60 | | 1912 | 82 | | | |
| | 4180 | 1161 | 82.6 | | 968 | 79 | | | |
| | 6960 | 1933 | 49 | | 1189 | 87 | | | |
| | 9050 | 2514 | 49 | | 1233 | 80 | | | |
| DMC 700-820F | 3600 | 1000 | 60 | 960 | 754 | 78 | 6.3 | 1000 | 705 |
| | 6010 | 1669 | 48 | | 913 | 86 | | | |
| | 7500 | 2083 | 36 | | 930 | 79 | | | |
| | 3240 | 900 | 72.8 | | 834 | 77 | | | |
| | 5400 | 1503 | 60 | | 1002 | 88 | | | |
| | 6600 | 1833 | 46 | | 1020 | 81 | | | |
| DMC 800-740E | 5200 | 1444 | 34.5 | 725 | 660 | 74 | 7.0 | 800 | 790 |
| | 8640 | 2400 | 24.3 | | 864 | 86 | | | |
| | 10300 | 2861 | 16.5 | | 985 | 79 | | | |
| | 4970 | 1381 | 31.6 | | 578 | 74 | | | |
| | 8280 | 2300 | 22.3 | | 584 | 86 | | | |
| | 9850 | 2736 | 14.8 | | 502 | 79 | | | |
| DMC 800-740F | 4700 | 1306 | 29 | 725 | 501 | 74 | 5.5 | 560 | 690 |
| | 7850 | 2180 | 20 | | 497 | 86 | | | |
| | 9200 | 2556 | 14 | | 444 | 79 | | | |
| | 4360 | 1211 | 30.8 | | 487 | 75 | | | |
| | 7270 | 2019 | 22.2 | | 511 | 89 | | | |
| | 9150 | 2522 | 13 | | 432 | 75 | | | |
| DMC 800-740F | 4170 | 1158 | 28.6 | 725 | 433 | 75 | 7.0 | 500 | 690 |
| | 6950 | 1931 | 20.6 | | 459 | 85 | | | |
| | 8720 | 2422 | 12.5 | | 396 | 75 | | | |
| | 3960 | 1100 | 26 | | 379 | 74 | | | |
| | 6600 | 1833 | 18.5 | | 396 | 84 | | | |
| | 8250 | 2292 | 11.4 | | 346 | 74 | | | |
| DMC 800-740F | 3760 | 1044 | 23.8 | 725 | 334 | 73 | 6.0 | 400 | 630 |
| | 6260 | 1739 | 16.5 | | 335 | 84 | | | |
| | 7700 | 2139 | 10.5 | | 297 | 74 | | | |

参数表 Standard performance

| 泵型号 Type | 流量 Capacity Q | | 扬程 Head m | 转速 Speed r/min | 轴功率 Shaft power kW | 效率 eff % | 有效汽 蚀余量 NPSHa m | 电机功率 Motor power kW | 叶轮参 考直径 D(mm) |
|-----------------|---------------------|------|-----------------|----------------------|-----------------------------|----------------|--------------------------|------------------------------|---------------------|
| | m³/h | l/s | | | | | | | |
| DMC 700-820E | 4430 | 1231 | 92 | 960 | 1387 | 80 | 8.8 | 2000 | 835 |
| | 7380 | 2050 | 80 | | 1806 | 89 | | | |
| | 9600 | 2667 | 60 | | 1912 | 82 | | | |
| | 4180 | 1161 | 82.6 | | 968 | 79 | | | |
| | 6960 | 1933 | 49 | | 1189 | 87 | | | |
| | 9050 | 2514 | 49 | | 1233 | 80 | | | |
| DMC 700-820F | 3600 | 1000 | 60 | 960 | 754 | 78 | 6.3 | 1000 | 705 |
| | 6010 | 1669 | 48 | | 913 | 86 | | | |
| | 7500 | 2083 | 36 | | 930 | 79 | | | |
| | 3240 | 900 | 72.8 | | 834 | 77 | | | |
| | 5400 | 1503 | 60 | | 1002 | 88 | | | |
| | 6600 | 1833 | 46 | | 1020 | 81 | | | |
| DMC 800-740E | 5200 | 1444 | 34.5 | 725 | 660 | 74 | 7.0 | 800 | 790 |
| | 8640 | 2400 | 24.3 | | 864 | 86 | | | |
| | 10300 | 2861 | 16.5 | | 985 | 79 | | | |
| | 4970 | 1381 | 31.6 | | 578 | 74 | | | |
| | 8280 | 2300 | 22.3 | | 584 | 86 | | | |
| | 9850 | 2736 | 14.8 | | 502 | 79 | | | |
| DMC 800-740F | 4700 | 1306 | 29 | 725 | 501 | 74 | 5.5 | 560 | 690 |
| | 7850 | 2180 | 20 | | 497 | 86 | | | |
| | 9200 | 2556 | 14 | | 444 | 79 | | | |
| | 4360 | 1211 | 30.8 | | 487 | 75 | | | |
| | 7270 | 2019 | 22.2 | | 511 | 89 | | | |
| | 9150 | 2522 | 13 | | 432 | 75 | | | |
| DMC 800-740F | 4170 | 1158 | 28.6 | 725 | 433 | 75 | 7.0 | 500 | 690 |
| | 6950 | 1931 | 20.6 | | 459 | 85 | | | |
| | 8720 | 2422 | 12.5 | | 396 | 75 | | | |
| | 3960 | 1100 | 26 | | 379 | 74 | | | |
| | 6600 | 1833 | 18.5 | | 396 | 84 | | | |
| | 8250 | 2292 | 11.4 | | 346 | 74 | | | |
| DMC 800-740F | 3760 | 1044 | 23.8 | 725 | 334 | 73 | 6.0 | 400 | 630 |
| | 6260 | 1739 | 16.5 | | 335 | 84 | | | |
| | 7700 | 2139 | 10.5 | | 297 | 74 | | | |

主要外型尺寸 pump outline size

| 泵型号 type | 法兰尺寸 flange size | | | | | | | | | | 泵尺寸 pump size | | | | | | 泵重量 W.T kg | | |
|-------------|-------------------|----|------|------|--------|--------------------|----|-----|------|--------|---------------|------|------|------|-----|-----|------------------|------|------|
| | 进口法兰 inlet flange | | | | | 出口法兰 outlet flange | | | | | a1 | a2 | h1 | h2 | h3 | h4 | | l1 | f |
| | DN1 | S1 | K | D | n-φd | DN2 | S2 | K | D | n-φd | | | | | | | | | |
| 700-820 | 800 | 54 | 950 | 1020 | 24-φ41 | 700 | 54 | 840 | 910 | 24-φ41 | 1250 | 1250 | 1200 | 2050 | 650 | 650 | 1160 | 1440 | 6075 |
| 800-740 | 900 | 54 | 1050 | 1120 | 28-φ41 | 800 | 54 | 950 | 1020 | 24-φ41 | 1400 | 950 | 1380 | 2300 | 770 | 770 | 1180 | 1410 | 6557 |

连接尺寸 connection size

| 泵型号 type | 电机 Motor | | 12 | 13 | 14 | b1 | b2 | b3 | 15 | 16 | 17 | b4 | b5 | h5 | h6 | q | 地脚螺栓 anchor | | 电机最大重量 motor W.T | |
|-------------|-------------|-----------|-----|-----|-----|-----|------|-----|------|------|------|------|------|-----|------|------|-------------|----------|---------------------|------|
| | 型号 Type | 功率(kW) | | | | | | | | | | | | | | | 泵 pump | 电机 motor | | |
| 700-820 | Y560-6(6kV) | 1600-2000 | | | | | | | 2195 | 1400 | 1880 | 1000 | 1130 | 560 | 1160 | 2715 | M42×800 | M36×600 | 5680 | |
| | Y500-6(6kV) | 1000-1400 | 775 | 775 | 350 | 790 | 1090 | 150 | 2170 | 1250 | 1730 | 900 | 1010 | 500 | 1040 | 2550 | | | M30×600 | 4600 |
| | Y455-6(6kV) | 630-900 | | | | | | | 2010 | 1120 | 1620 | 800 | 910 | 450 | 935 | 2080 | | | | |
| 800-740 | Y450-8(6kV) | 630-800 | | | | | | | 1980 | 1120 | 1620 | 800 | 910 | 450 | 935 | 2080 | M42×800 | M30×600 | 3850 | |
| | Y400-8(6kV) | 400-560 | 550 | 700 | 400 | 890 | 1190 | 150 | 1960 | 1000 | 1510 | 710 | 810 | 400 | 835 | 1940 | | | | |

DMC800-840 E Curve n=725r/min

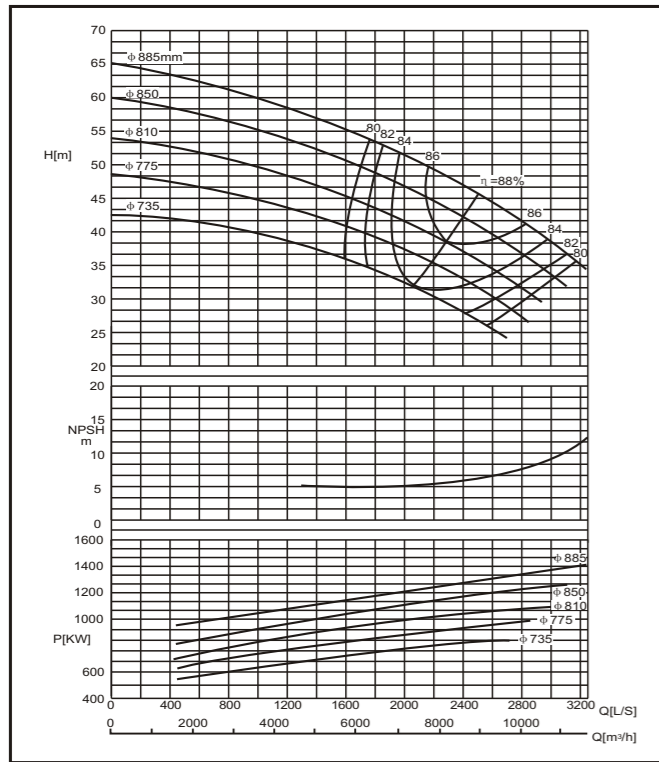

DMC800-840 F Curve n=725r/min

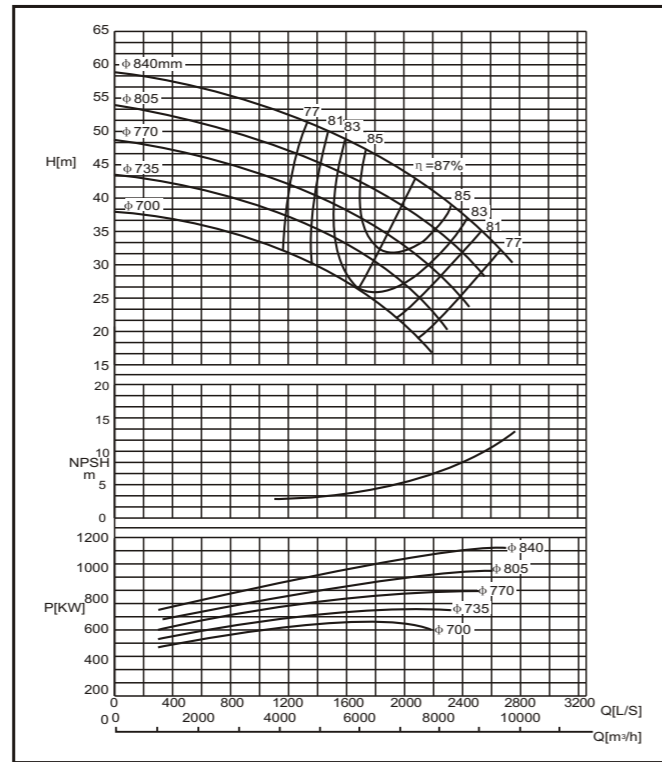

DMC800-970 E Curve n=725r/min

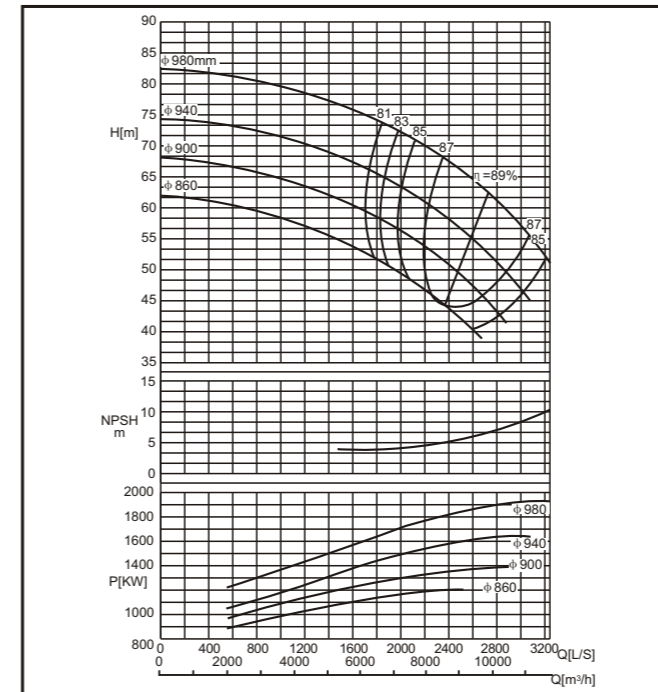

DMC800-970 F Curve n=725r/min

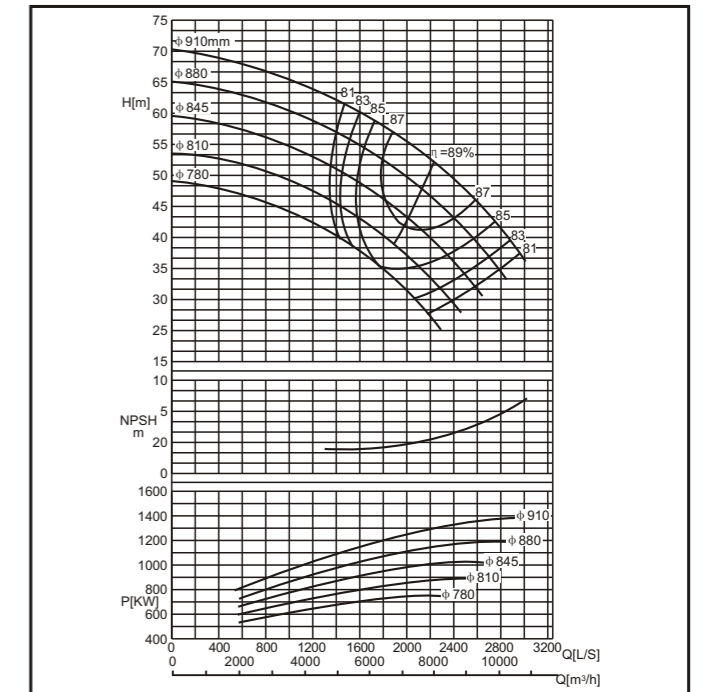

DMC卧式泵安装尺寸图 Installing dimensions of DMC pumps

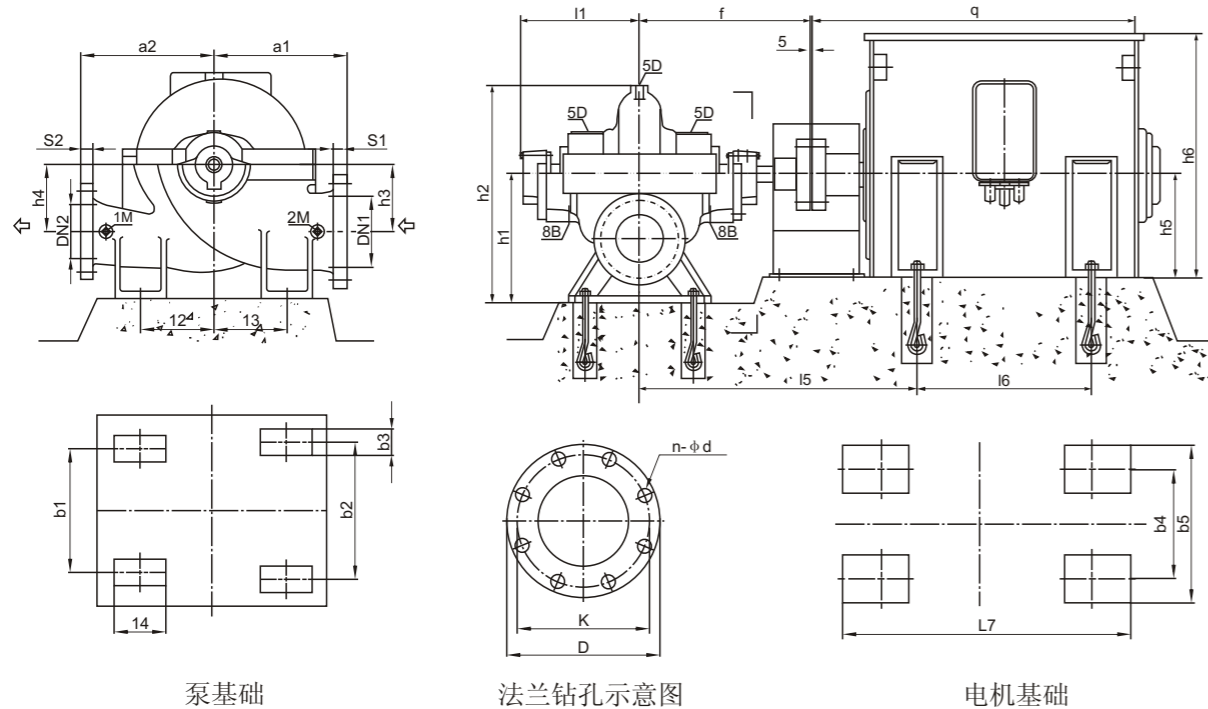

连接尺寸 connection dimensions:

- 1M、2M 压力表 Rp1/2 1M、2M pressure gauge Rp1/2
- 5D 排气孔 Rp1/2 5D air vent Rp1/2
- 6B 排液孔 Rp3/4 6B drain plug Rp3/4
- 8B 漏液排出孔 Rp3/4 8B drain plug Rp3/4

参数表 Standard performance

| 泵型号 Type | 流量 Capacity Q | | 扬程 Head m | 转速 Speed r/min | 轴功率 Shaft power kW | 效率 eff η % | 有效汽 蚀余量 NPSHa m | 电机功率 Motor power kW | 叶轮参 考直径 D(mm) |
|-----------------|---------------------|------|-----------------|----------------------|-----------------------------|------------------|--------------------------|------------------------------|---------------------|
| | m³/h | l/s | | | | | | | |
| DMC 800-840E | 5400 | 1500 | 56.4 | 725 | 1063 | 78 | 6.3 | 1400 | 885 |
| | 9000 | 2500 | 46 | | 1281 | 88 | | | |
| | 11700 | 3250 | 34.5 | | 1391 | 79 | | | |
| | 5200 | 1444 | 52.2 | | 947 | 78 | | | |
| | 8650 | 2403 | 42.3 | | 1145 | 87 | | | |
| | 11160 | 3100 | 32 | | 1231 | 79 | | | |
| DMC 800-840F | 4960 | 1378 | 47.5 | 725 | 833 | 77 | 5.5 | 1120 | 810 |
| | 8260 | 2204 | 38.5 | | 1007 | 86 | | | |
| | 10600 | 2944 | 30 | | 1096 | 79 | | | |
| | 4710 | 1308 | 4.3 | | 725 | 76 | | | |
| | 7850 | 2181 | 35.4 | | 880 | 96 | | | |
| | 10200 | 2853 | 26.8 | | 954 | 78 | | | |
| DMC 800-970E | 4470 | 1242 | 38.5 | 725 | 625 | 75 | 5.0 | 900 | 735 |
| | 7450 | 2069 | 32.2 | | 768 | 85 | | | |
| | 9700 | 2694 | 24.3 | | 833 | 77 | | | |
| | 4500 | 1250 | 5.3 | | 854 | 76 | | | |
| | 7500 | 2083 | 4.3 | | 1009 | 87 | | | |
| | 9750 | 2708 | 31.3 | | 1093 | 76 | | | |
| DMC 800-970F | 4300 | 1194 | 47.5 | 725 | 741 | 75 | 4.5 | 900 | 770 |
| | 7150 | 1986 | 39 | | 883 | 87 | | | |
| | 9180 | 2550 | 28 | | 954 | 75 | | | |
| | 4600 | 1278 | 58.3 | | 924 | 79 | | | |
| | 7650 | 2125 | 47.8 | | 1131 | 88 | | | |
| | 9950 | 2764 | 35.3 | | 1166 | 82 | | | |

参数表 Standard performance

| 泵型号 Type | 流量 Capacity Q | | 扬程 Head m | 转速 Speed r/min | 轴功率 Shaft power kW | 效率 eff η % | 有效汽 蚀余量 NPSHa m | 电机功率 Motor power kW | 叶轮参 考直径 D(mm) |
|-----------------|---------------------|------|-----------------|----------------------|-----------------------------|------------------|--------------------------|------------------------------|---------------------|
| | m³/h | l/s | | | | | | | |
| DMC 800-840E | 5880 | 1633 | 75.5 | 725 | 1530 | 79 | 7.1 | 2000 | 980 |
| | 9800 | 2722 | 62.5 | | 1873 | 89 | | | |
| | 11600 | 3222 | 51.2 | | 1902 | 85 | | | |
| | 5580 | 1550 | 67.5 | | 1298 | 79 | | | |
| | 9300 | 2583 | 55 | | 1565 | 89 | | | |
| | 11000 | 3056 | 45.2 | | 1611 | 84 | | | |
| DMC 800-970E | 5300 | 1472 | 61.5 | 725 | 988 | 78 | 5.0 | 1400 | 860 |
| | 8890 | 2469 | 49.5 | | 1184 | 87 | | | |
| | 10400 | 2889 | 41.3 | | 1203 | 83 | | | |
| | 5100 | 1417 | 55.5 | | 988 | 78 | | | |
| | 8000 | 2361 | 44.5 | | 1184 | 87 | | | |
| | 9650 | 2881 | 38 | | 1203 | 83 | | | |
| DMC 800-970F | 4800 | 1333 | 63 | 725 | 1029 | 80 | 6.8 | 1400 | 910 |
| | 8000 | 2222 | 62 | | 1272 | 89 | | | |
| | 10450 | 2903 | 39 | | 1337 | 83 | | | |
| | 4600 | 1278 | 58.3 | | 924 | 79 | | | |
| | 7650 | 2125 | 47.8 | | 1131 | 88 | | | |
| | 9950 | 2764 | 35.3 | | 1166 | 82 | | | |

主要外型尺寸 pump outline size

| 泵型号 type | 法兰尺寸 flange size | | | | | | | | | | 泵尺寸 pump size | | | | | | 泵重量 W.T kg | | |
|-------------|-------------------|----|------|------|--------|--------------------|----|-----|------|--------|---------------|------|------|------|-----|-----|------------------|------|------|
| | 进口法兰 inlet flange | | | | | 出口法兰 outlet flange | | | | | | | | | | | | | |
| | DN1 | S1 | K | D | n-φd | DN2 | S2 | K | D | n-φd | a1 | a2 | h1 | h2 | h3 | h4 | | l1 | f |
| 800-840 | 900 | 54 | 1050 | 1120 | 28-φ41 | 800 | 54 | 950 | 1020 | 24-φ41 | 1400 | 1125 | 1360 | 2260 | 770 | 770 | 1180 | 1500 | 6624 |
| 800-970 | 900 | 54 | 1050 | 1120 | 28-φ41 | 800 | 54 | 950 | 1020 | 24-φ41 | 1400 | 1300 | 1370 | 2220 | 760 | 760 | 1270 | 1580 | 7809 |

连接尺寸 connection size

| 泵型号 type | 电机 Motor | | 12 | 13 | 14 | b1 | b2 | b3 | 15 | 16 | 17 | b4 | b5 | h5 | h6 | q | 地脚螺栓 anchor | | 电机最大重量 motor W.T |
|-------------|-------------|-----------|-----|-----|-----|-----|------|-----|------|------|------|------|------|-----|------|------|-------------|----------|---------------------|
| | 型号 Type | 功率(kW) | | | | | | | | | | | | | | | 泵 pump | 电机 motor | |
| 800-840 | Y500-8(6kV) | 1000-1400 | 700 | 750 | 400 | 890 | 1190 | 150 | 2230 | 1250 | 1730 | 900 | 1010 | 500 | 1040 | 2550 | M42×800 | M36×600 | 4600 |
| | Y450-8(6kV) | 630-900 | | | | | | | | | | | | | | | | M30×600 | 3850 |
| 800-970 | Y560-8(6kV) | 1600-2000 | 800 | 800 | 400 | 890 | 1190 | 150 | 2335 | 1400 | 1880 | 1000 | 1130 | 560 | 1160 | 2715 | M42×800 | M36×600 | 5680 |
| | Y500-8(6kV) | 1000-1400 | | | | | | | | | | | | | | | | M30×600 | 4600 |
| | Y450-8(6kV) | 800-900 | | | | | | | | | | | | | | | | | M30×600 |

DMCL立式泵安装尺寸 Installing dimensions of DMCL pumps(SBS80-210 SBS350-510)

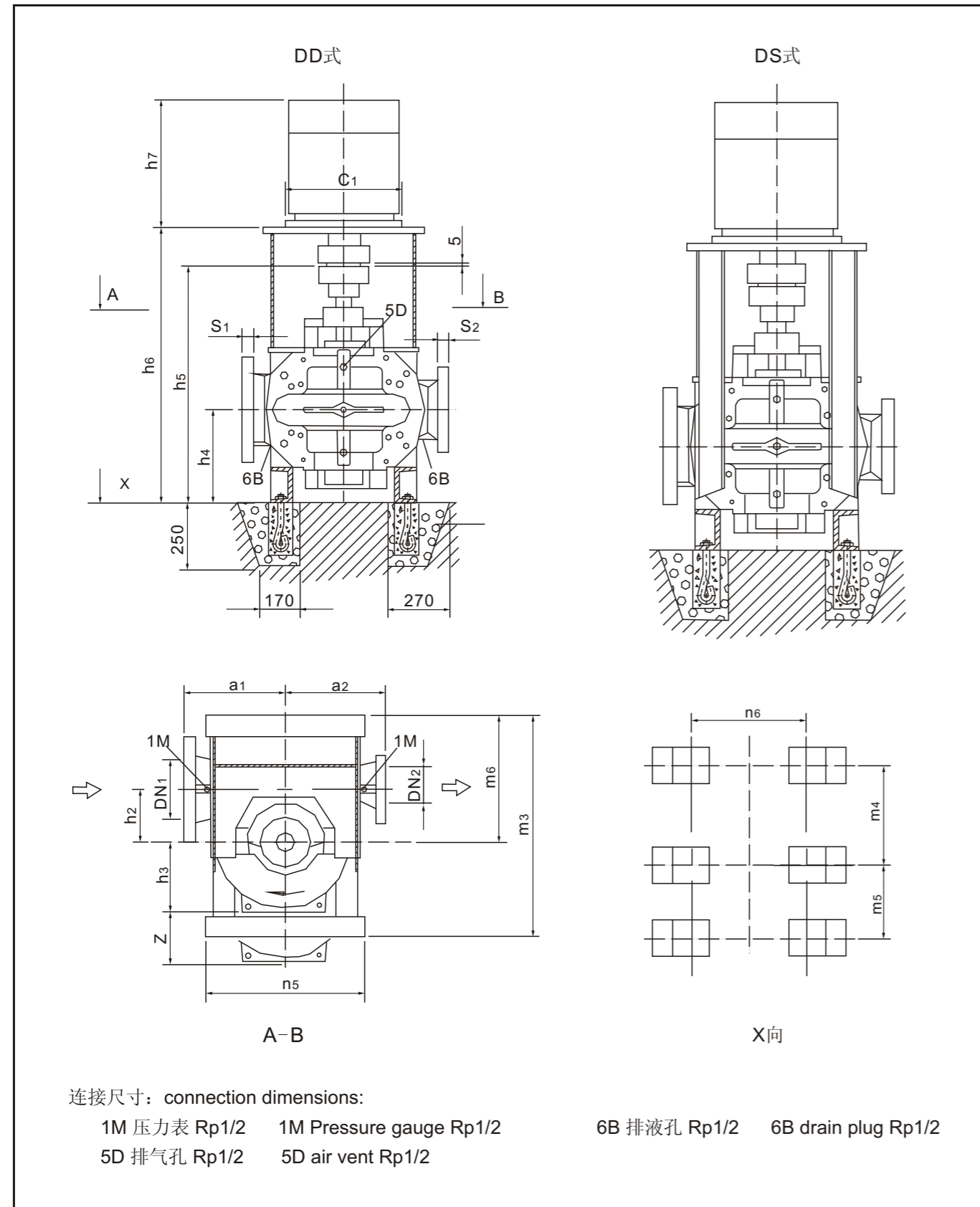

泵主要外形尺寸 Outline dimensions of DMCL pumps

| 泵型号 type | 法兰尺寸 flange size | | | | 泵尺寸 pump size | | | | | | | 泵重量WT | |
|-------------|------------------|-----------------|----------------|----------------|----------------|----------------|----------------|----------------|----------------|----------------|-----|--------|-------|
| | DN ₁ | DN ₂ | S ₁ | S ₂ | a ₁ | a ₂ | h ₂ | h ₃ | h ₄ | h ₅ | Z | 净重N·TN | 湿重G·W |
| 80-210 | 125 | 80 | 34.1 | 28.6 | 300 | 300 | 140 | 168 | 320 | 715 | 340 | 185 | 195 |
| 80-270 | | | | | 190 | 210 | | | | | | | |
| 80-370 | | | | | 225 | 225 | | | | | | | |

| 泵型号 type | 法兰尺寸 flange size | | | | 泵尺寸 pump size | | | | | | | 泵重量W.T | |
|-------------|------------------|-----------------|----------------|----------------|----------------|----------------|----------------|----------------|----------------|----------------|-----|--------|-------|
| | DN ₁ | DN ₂ | S ₁ | S ₂ | a ₁ | a ₂ | h ₂ | h ₃ | h ₄ | h ₅ | Z | 净重N·TN | 湿重G·W |
| 100-250 | 150 | 100 | 36.5 | 31.8 | 330 | 330 | 170 | 195 | 300 | 715 | 390 | 210 | 230 |
| 100-310 | | | | | 225 | 250 | | | | | | | |
| 100-375 | | | | | 260 | 275 | | | | | | | |

| 泵型号 type | 法兰尺寸 flange size | | | | 泵尺寸 pump size | | | | | | | 泵重量W.T | |
|-------------|------------------|-----------------|----------------|----------------|----------------|----------------|----------------|----------------|----------------|----------------|-----|--------|-------|
| | DN ₁ | DN ₂ | S ₁ | S ₂ | a ₁ | a ₂ | h ₂ | h ₃ | h ₄ | h ₅ | Z | 净重N·TN | 湿重G·W |
| 125-230 | 200 | 125 | 41.3 | 34.3 | 370 | 370 | 200 | 210 | 355 | 870 | 420 | 250 | 285 |
| 125-290 | | | | | | | | 230 | | | | 315 | |
| 125-365 | | | | | | | | 260 | | | | 345 | |
| 125-500 | | | | | | | | 305 | | | | 380 | |

| 泵型号 type | 法兰尺寸 flange size | | | | 泵尺寸 pump size | | | | | | | 泵重量W.T | |
|-------------|------------------|-----------------|----------------|----------------|----------------|----------------|----------------|----------------|----------------|----------------|-----|--------|-------|
| | DN ₁ | DN ₂ | S ₁ | S ₂ | a ₁ | a ₂ | h ₂ | h ₃ | h ₄ | h ₅ | Z | 净重N·TN | 湿重G·W |
| 150-290 | 200 | 150 | 41.3 | 36.5 | 400 | 400 | 200 | 245 | 355 | 870 | 490 | 350 | 400 |
| 150-360 | | | | | | | | 265 | | | | 420 | |
| 150-460 | | | | | | | | 305 | | | | 511 | |
| 150-605 | | | | | | | | 600 | | | | 736 | |

| 泵型号 type | 法兰尺寸 flange size | | | | 泵尺寸 pump size | | | | | | | 泵重量W.T | |
|-------------|------------------|-----------------|----------------|----------------|----------------|----------------|----------------|----------------|----------------|----------------|-----|--------|-------|
| | DN ₁ | DN ₂ | S ₁ | S ₂ | a ₁ | a ₂ | h ₂ | h ₃ | h ₄ | h ₅ | Z | 净重N·TN | 湿重G·W |
| 200-320 | 250 | 200 | 47.6 | 41.3 | 450 | 450 | 240 | 285 | 400 | 990 | 570 | 450 | 530 |
| 200-420 | | | | | 500 | 615 | | | | | | | |
| 200-520 | | | | | 600 | 955 | | | | | | | |
| 200-670 | | | | | 650 | 1130 | | | | | | | |

| 泵型号 type | 法兰尺寸 flange size | | | | 泵尺寸 pump size | | | | | | | 泵重量W.T | |
|-------------|------------------|-----------------|----------------|----------------|----------------|----------------|----------------|----------------|----------------|----------------|-----|--------|-------|
| | DN ₁ | DN ₂ | S ₁ | S ₂ | a ₁ | a ₂ | h ₂ | h ₃ | h ₄ | h ₅ | Z | 净重N·TN | 湿重G·W |
| 250-370 | 300 | 250 | 50.8 | 47.5 | 500 | 500 | 300 | 320 | 440 | 1095 | 640 | 665 | 790 |
| 250-480 | | | | | 550 | 975 | | | | | | | |
| 250-600 | | | | | 650 | 1395 | | | | | | | |
| 250-710 | | | | | 750 | 1855 | | | | | | | |

| 泵型号 type | 法兰尺寸 flange size | | | | 泵尺寸 pump size | | | | | | | 泵重量W.T | |
|-------------|------------------|-----------------|----------------|----------------|----------------|----------------|----------------|----------------|----------------|----------------|-----|--------|-------|
| | DN ₁ | DN ₂ | S ₁ | S ₂ | a ₁ | a ₂ | h ₂ | h ₃ | h ₄ | h ₅ | Z | 净重N·TN | 湿重G·W |
| 300-300 | 350 | 300 | 54 | 50.8 | 550 | 500 | 300 | 360 | 440 | 1095 | 720 | 630 | 730 |
| 300-435 | 650 | | 550 | | 500 | 1230 | | 905 | | | | 1095 | |
| 300-560 | 700 | | 650 | | 570 | 1380 | | 860 | | | | 1425 | 1650 |
| 300-700 | 750 | | 650 | | 400 | 480 | | 570 | | | | 1380 | 960 |

| 泵型号 type | 法兰尺寸 flange size | | | | 泵尺寸 pump size | | | | | | | 泵重量W.T | | |
|-------------|------------------|-----------------|----------------|----------------|----------------|----------------|----------------|----------------|----------------|----------------|-----|--------|-------|------|
| | DN ₁ | DN ₂ | S ₁ | S ₂ | a ₁ | a ₂ | h ₂ | h ₃ | h ₄ | h ₅ | Z | 净重N·TN | 湿重G·W | |
| 350-360 | 400 | 350 | 57.2 | 54 | 650 | 500 | 350 | 410 | 500 | 1230 | 820 | 865 | 1025 | |
| 350-430 | 450 | | 60.3 | | 750 | 650 | | 465 | | | | 930 | 1285 | 1525 |
| 350-510 | 400 | | 57.2 | | 700 | 650 | | 420 | | | | 840 | 1395 | 1685 |
| 350-590 | 500 | | 63.4 | | 750 | 650 | | 465 | | | | 960 | 1510 | 1800 |

z: 拆卸转子所需最小空间尺寸 z: min. dimension of disinsalling the rotating assembly.

电机尺寸-Y型电机 Y-series motors dimersions

| 泵型号 type | 结构型式 structure | | 电机型号 Motor | h6 | h7 | m3 | m4 | m5 | m6 | n5 | n6 | 电机重量 Motor W • t(kg) | |
|-------------|-------------------|----|---------------|-----|------|-----|-----|-----|-----|-----|-----|-------------------------|-----|
| | DD | DS | | | | | | | | | | | |
| 80-210 | ● | — | Min.90L | 770 | 295 | 640 | 275 | 100 | 380 | 450 | 340 | 28 | |
| | | | Max.200L | 740 | 255 | | | | | | | | |
| | — | ● | Min.225M | 830 | 795 | | | | | | | 720 | 308 |
| | | | Max.225M | 720 | 308 | | | | | | | | |
| 80-270 | ● | — | Min.100L | 780 | 320 | 640 | 275 | 100 | 380 | 450 | 340 | 29 | |
| | | | Max200L | 830 | 740 | | | | | | | 255 | |
| | — | ● | Min.225M | 830 | 795 | | | | | | | 720 | 308 |
| | | | Max.280M | 860 | 1030 | | | | | | | 620 | |
| 80-370 | ● | — | Min.132S | 800 | 395 | 640 | 275 | 100 | 380 | 450 | 340 | 72 | |
| | | | Max.180L | 830 | 660 | | | | | | | 200 | |

| 泵型号 type | 结构型式 structure | | 电机型号 Motor | h6 | h7 | m3 | m4 | m5 | m6 | n5 | n6 | 电机重量 Motor W • t(kg) | |
|-------------|-------------------|----|---------------|------|------|-----|-----|-----|-----|-----|-----|-------------------------|-----|
| | DD | DS | | | | | | | | | | | |
| 100-250 | ● | — | Min.100L | 780 | 320 | 695 | 315 | 115 | 420 | 500 | 400 | 39 | |
| | | | Max.225L | 830 | 795 | | | | | | | 308 | |
| | — | ● | Min.250M | 860 | 895 | | | | | | | 760 | 403 |
| | | | Max.315S | 1220 | 980 | | | | | | | | |
| 100-310 | ● | — | Max.132M | 880 | 435 | 695 | 315 | 115 | 420 | 500 | 400 | 84 | |
| | | | Max.225M | 830 | 795 | | | | | | | 308 | |
| | — | ● | Min.250M | 860 | 895 | | | | | | | 760 | 403 |
| | | | Max.315L | 1320 | 1220 | | | | | | | | |
| 100-375 | ● | — | Min.160M | 830 | 495 | 695 | 315 | 115 | 420 | 500 | 400 | 130 | |
| | | | Max.225M | 860 | 795 | | | | | | | 320 | |
| | — | ● | Min.250M | 860 | 895 | | | | | | | 760 | 427 |
| | | | Max.250M | 895 | 760 | | | | | | | 427 | |

| 泵型号 type | 结构型式 structure | | 电机型号 Motor | h6 | h7 | m3 | m4 | m5 | m6 | n5 | n6 | 电机重量 Motor W • t(kg) | |
|-------------|-------------------|----|---------------|------|------|-----|-----|-----|-----|-----|-----|-------------------------|-----|
| | DD | DS | | | | | | | | | | | |
| 125-230 | ● | — | Min.132S | 955 | 395 | 855 | 360 | 210 | 475 | 600 | 450 | 72 | |
| | | | Max.280M | 1030 | 620 | | | | | | | | |
| | — | ● | Min.315S | 1015 | 1220 | | | | | | | 820 | 980 |
| | | | Max.315M | 1320 | 1080 | | | | | | | | |
| 125-290 | ● | — | Min.132M | 955 | 435 | 855 | 360 | 210 | 475 | 600 | 450 | 84 | |
| | | | Max.280M | 1030 | 620 | | | | | | | | |
| | — | ● | Min.315S | 1015 | 1220 | | | | | | | 820 | 980 |
| | | | Max.315L | 1320 | 1220 | | | | | | | | |
| 125-365 | ● | — | Min.160L | 985 | 540 | 855 | 360 | 210 | 475 | 600 | 450 | 145 | |
| | | | Max.280S | 1015 | 980 | | | | | | | 562 | |
| 125-500 | ● | — | Min.200L | 985 | 740 | 855 | 360 | 210 | 475 | 600 | 450 | 270 | |
| | | | Max.315M | 1045 | 1320 | | | | | | | 1100 | |

| 泵型号 type | 结构型式 structure | | 电机型号 Motor | h6 | h7 | m3 | m4 | m5 | m6 | n5 | n6 | 电机重量 Motor W • t(kg) |
|-------------|-------------------|----|---------------|------|------|------|-----|-----|-----|-----|-----|-------------------------|
| | DD | DS | | | | | | | | | | |
| 150-290 | ● | — | Min.160M | 985 | 495 | 855 | 360 | 210 | 475 | 600 | 450 | 130 |
| | | | Max.225M | 1015 | 795 | | | | | | | 320 |
| 150-360 | ● | — | Min.180M | 985 | 620 | 855 | 360 | 210 | 475 | 600 | 450 | 180 |
| | | | Max.280S | 1015 | 980 | | | | | | | 562 |
| 150-460 | ● | — | Min.200L | 1105 | 740 | 855 | 360 | 210 | 475 | 700 | 560 | 270 |
| | | | Max.315L | 1165 | 1320 | | | | | | | 1240 |
| 150-605 | ● | — | Min.250M | 1135 | 895 | 1060 | 460 | 315 | 575 | 900 | 700 | 427 |
| | | | Max.YL3552 | 1205 | 1710 | | | | | | | 2330 |
| | — | ● | Min.YL3553 | 1205 | 1710 | | | | | | | 2490 |
| | | | Max.YL3554 | 1340 | 460 | | | | | | | 315 |

尺 -Y Y-series motors dimersions

| 泵型号 type | 结构型式 structure | | 电机型号 Motor | c1 | h6 | h7 | m3 | m4 | m5 | m6 | n5 | n6 | 电机重量 Motor W • t(kg) |
|-------------|-------------------|----|---------------|------|------|------|------|------|------|-----|-----|-----|-------------------------|
| | DD | DS | | | | | | | | | | | |
| 200-320 | ● | — | Min.200L | 400 | 1105 | 740 | 1060 | 460 | 315 | 575 | 700 | 560 | 270 |
| | | | Max.280M | 550 | 1135 | 1030 | | | | | | | 667 |
| 200-420 | ● | — | Min.225S | 450 | 1135 | 770 | 1060 | 460 | 315 | 575 | 700 | 560 | 284 |
| | | | Max.315L | 660 | 1165 | 1320 | | | | | | | 1240 |
| 200-520 | ● | — | Min.280S | 550 | 1240 | 980 | 1120 | 520 | 315 | 635 | 900 | 700 | 562 |
| | | | Max.YL3552 | 1150 | 1310 | 1710 | | | | | | | 2330 |
| | — | ● | Min.YL3553 | 1150 | 1310 | 1710 | 1400 | 1300 | 2490 | | | | |
| | | | Max.YL4002 | 1150 | 1310 | 1850 | 3000 | | | | | | |
| 200-670 | ● | — | Min.315S | 660 | 1270 | 1220 | 1180 | 560 | 315 | 685 | 900 | 700 | 1000 |
| | | | Max.YL3552 | 1150 | 1310 | 1710 | | | | | | | 2330 |
| | — | ● | Min.YL3553 | 1150 | 1310 | 1710 | 1460 | 1300 | 2490 | | | | |
| | | | Max.YL4005 | 1150 | 1310 | 1850 | 3240 | | | | | | |

| 泵型号 type | 结构型式 structure | | 电机型号 Motor | c1 | h6 | h7 | m3 | m4 | m5 | m6 | n5 | n6 | 电机重量 Motor W • t(kg) |
|-------------|-------------------|----|---------------|------|------|------|------|------|------|-----|------|-----|-------------------------|
| | DD | DS | | | | | | | | | | | |
| 250-370 | ● | — | Min.280S | 550 | 1240 | 980 | 1180 | 560 | 315 | 685 | 900 | 700 | 562 |
| | | | Max.315L | 660 | 1270 | 1320 | | | | | | | 1240 |
| 250-480 | ● | — | Min.280M | 550 | 1375 | 1030 | 1180 | 560 | 315 | 685 | 900 | 700 | 667 |
| | | | Max.YL3552 | 1150 | 1445 | 1710 | | | | | | | 2330 |
| | — | ● | Min.YL3553 | 1150 | 1445 | 1710 | 1460 | 1300 | 2490 | | | | |
| | | | Max.YL4001 | 1150 | 1445 | 1850 | 2960 | | | | | | |
| 250-600 | ● | — | Min.315M | 660 | 1405 | 1320 | 1210 | 590 | 315 | 715 | 900 | 950 | 1100 |
| | | | Max.YL3552 | 1150 | 1445 | 1720 | | | | | | | 2330 |
| | — | ● | Min.YL3553 | 1150 | 1445 | 1710 | 1490 | 900 | 2490 | | | | |
| | | | Max.YL4502 | 1250 | 1445 | 2000 | 3430 | | | | | | |
| 250-710 | ● | — | Min.YL3554 | 1150 | 1595 | 1710 | 1415 | 710 | 400 | 835 | 1300 | 950 | 2650 |
| | | | Max.YL4503 | 1250 | 1595 | 2000 | | | | | | | 3520 |
| | — | ● | Min.YL4504 | 1250 | 1595 | 2000 | 1610 | 1400 | 4070 | | | | |
| | | | Max.YL5003 | 1400 | 1635 | 2000 | 1680 | 4720 | | | | | |

| 泵型号 type | 结构型式 structure | | 电机型号 Motor | c1 | h6 | h7 | m3 | m4 | m5 | m6 | n5 | n6 | 电机重量 Motor W • t(kg) |
|-------------|-------------------|----|---------------|------|------|------|------|------|------|-----|------|-----|-------------------------|
| | DD | DS | | | | | | | | | | | |
| 300-300 | ● | — | Min.200L | 400 | 1210 | 1220 | 1210 | 590 | 315 | 715 | 900 | 700 | 270 |
| | | | Max.315S | 660 | 1270 | 1000 | | | | | | | |
| 300-435 | ● | — | Min.280M | 550 | 1375 | 1030 | 1250 | 630 | 315 | 755 | 1300 | 700 | 667 |
| | | | Max.YL3552 | 1150 | 1445 | 1710 | | | | | | | 2330 |
| | — | ● | Min.YL3553 | 1150 | 1445 | 1710 | 1530 | 2490 | | | | | |
| | | | Max.YL4002 | 1150 | 1445 | 1850 | 3000 | | | | | | |
| 300-560 | ● | — | Min.315L | 660 | 1555 | 1320 | 1375 | 670 | 400 | 795 | 1200 | 950 | 1240 |
| | | | Max.YL4503 | 1250 | 1595 | 2000 | | | | | | | 3520 |
| 300-700 | ● | — | Min.YL3554 | 1150 | 1710 | 1710 | 1415 | 710 | 400 | 835 | 1300 | 950 | 2650 |
| | | | Max.YL4503 | 1250 | 1595 | 2000 | | | | | | | 3520 |
| | — | ● | Min.YL4504 | 1250 | 1595 | 2000 | 1610 | 1400 | 4070 | | | | |
| | | | Max.YL5003 | 1400 | 1635 | 2100 | 1680 | 4720 | | | | | |

| 泵型号 type | 结构型式 structure | | 电机型号 Motor | c1 | h6 | h7 | m3 | m4 | m5 | m6 | n5 | n6 | 电机重量 Motor W • t(kg) |
|-------------|-------------------|----|---------------|------|------|------|------|------|------|-----|------|-----|-------------------------|
| | DD | DS | | | | | | | | | | | |
| 350-360 | ● | — | Min.250M | 550 | 1375 | 895 | 1250 | 630 | 315 | 755 | 900 | 700 | 427 |
| | | | Max.315L | 660 | 1405 | 1320 | | | | | | | 1220 |
| | — | ● | Min.YL3551 | 1150 | 1445 | 1710 | | | | | | | 1530 |
| Max.YL3551 | | | 1150 | 1445 | 1710 | 2280 | | | | | | | |
| 350-430 | ● | — | Min.315M | 660 | 1555 | 1320 | 1415 | 710 | 400 | 835 | 1200 | 950 | 1100 |
| | | | Max.YL3552 | 1150 | 1595 | 1710 | | | | | | | 2330 |
| | — | ● | Min.YL3553 | 1150 | 1595 | 1710 | 1610 | 1300 | 2490 | | | | |
| | | | Max.YL4003 | 1150 | 1595 | 1850 | 3060 | | | | | | |
| 350-510 | ● | — | Min.YL3554 | 1150 | 1595 | 1710 | 1415 | 710 | 400 | 835 | 1200 | 950 | 2650 |
| | | | Max.YL4503 | 1250 | 1595 | 2000 | | | | | | | 3520 |
| 350-590 | — | ● | Min.YL4504 | 1250 | 1595 | 2000 | 1610 | 710 | 400 | 835 | 1300 | 950 | 4070 |
| | | | Max.YL5003 | 1400 | 1635 | 2100 | | | | | | | 1680 |